

GR

2018

GOCCIA ILLUMINAZIONE

CATALOGO GENERALE | GENERAL CATALOGUE



2018

GOCCIA ILLUMINAZIONE

Indice generale | Index

INCASSI A TERRA | GROUND RECESSED



PASSUM UP
pag. 58

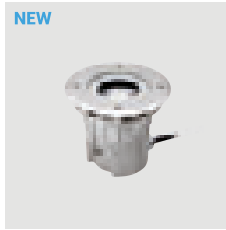

PASSUM UP CORPO INOX 316 L
316 L STAINLESS STEEL BODY
pag. 58



PASSUM UP ULTRAFLAT
pag. 62



PASSUM SIDEWARDS
pag. 68

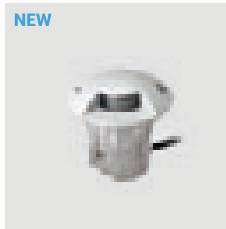

PASSUM SIDEWARDS
CORPO INOX 316 L
316 L STAINLESS STEEL BODY
pag. 68



PASSUM SIDEWARDS
ORIENTABILE/ADJUSTABLE
pag. 75

INCASSI A PARETE | WALL RECESSED



QUANTUM
pag. 24



COMPATTA
pag. 78



PASSUM UP
pag. 58



PASSUM SIDEWARDS
pag. 68

EFFETTI A PARETE | WALL EFFECT



WASH
pag. 158

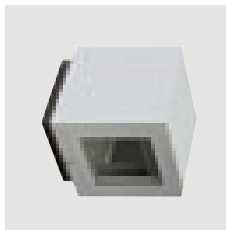

K³ WRITER
pag. 172



K³ MINILED
pag. 180



K³ POWER
pag. 188



CORINTHIA
pag. 196



VOLTO
pag. 206

PROIETTORI | PROJECTORS

NEW

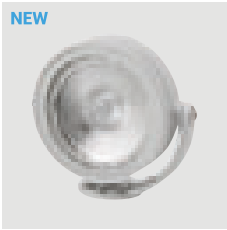

CLOCK
pag. 212



TRIALO
pag. 252



STRIKE
pag. 220



VOLTO
pag. 206

DOWNLIGHT



LUX SHOWER
pag. 234

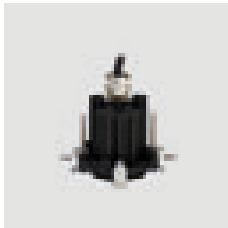

LUX SHOWER INSIDE
pag. 240

PALETTI DA GIARDINO | BOLLARDS FOR GARDEN

NEW



CANTHARELLUS
pag. 92



I-LUX
pag. 98



I-MAGO
pag. 106



I-DEA
pag. 112

NEW



STANDING
pag. 78



QUANTUM
pag. 46



COMPATTA
pag. 82

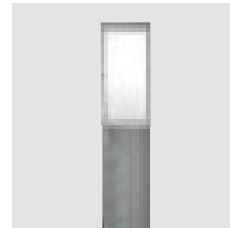

SMALL MIDI MAXI
pag. 138

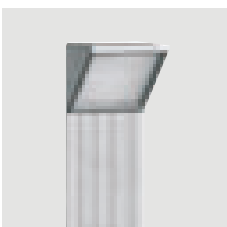

TRIANGOLO
pag. 151



KASKO
pag. 277

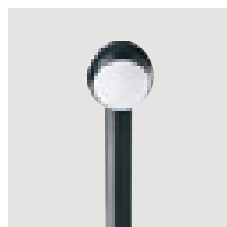

JACK
pag. 292

Indice generale | Index

TORRETTE MULTIFUNZIONE | GARDEN POWER POINTS



SERVER POINT
pag. 118

PLAFONIERE APPLIQUES | WALL/CEILING MOUNT



KASKO
pag. 266



DOCKS
pag. 256



FEELING
pag. 278

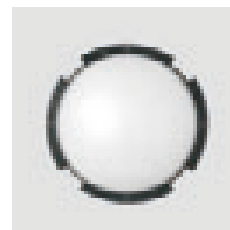

JACK
pag. 290

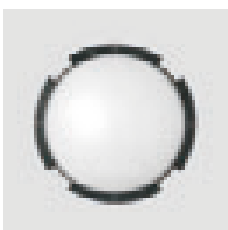

JACK LED
pag. 294



MARINA
pag. 298



MAGNUM
pag. 306

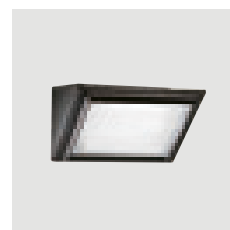

SMALL MIDI MAXI
pag. 124

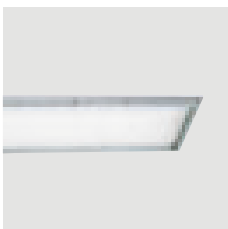

SUPERMAXI
pag. 124



TRIANGOLO
pag. 140



I-LUX
pag. 98



ACCENSIONI INDIPENDENTI
INDIVIDUAL CONTROL
pag. 314

RGB



RGBW K³
pag. 246

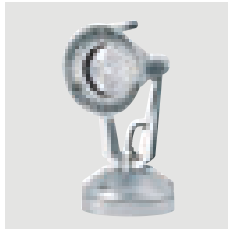

RGBW STRIKE 2
pag. 246



PASSUM UP RGBW
pag. 246

ARREDO URBANO | PATHWAYS AND PARK LUMINAIRES



TRIANGOLO CITY
pag. 154



COMPATTA
pag. 82



SUPERMAXI
pag. 132



LUX SHOWER
pag. 234



VOLTO
pag. 206

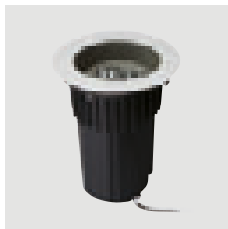

PASSUM UP
pag. 58

CORRIDOR FUNCTION



SUPERMAXI
pag. 136



TRIANGOLO CITY
pag. 157

Indice generale | Index

LAMPADIE PER OMBRELLONI | LUMINAIRES FOR BIG UMBRELLAS



SUMMERTIME
pag. 310

INOX | 316L STAINLESS STEEL LUMINAIRES

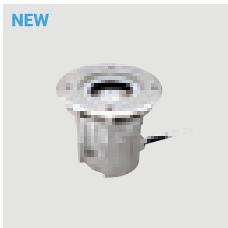

PASSUM UP CORPO INOX 316 L
316 L STAINLESS STEEL BODY
pag. 58

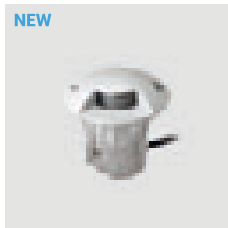

PASSUM SIDWARDS
CORPO INOX 316 L
316 L STAINLESS STEEL BODY
pag. 68



QUANTUM
pag. 39

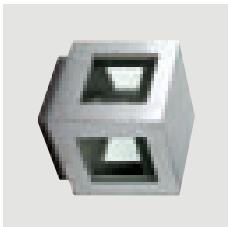

K³ WRITER
pag. 177

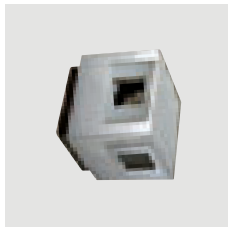

K³ MINILED
pag. 186

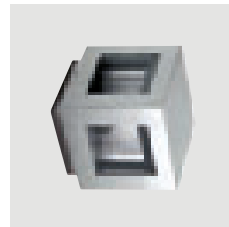

K³ POWER
pag. 193

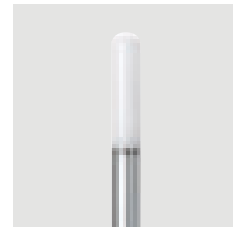

I-LUX
pag. 98

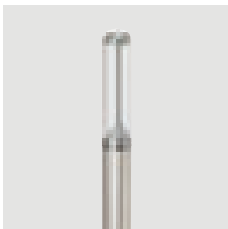

I-MAGO
pag. 106

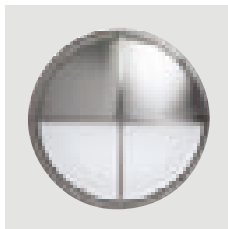

DOCKS
pag. 262

OTTONE | BRASS LUMINAIRES

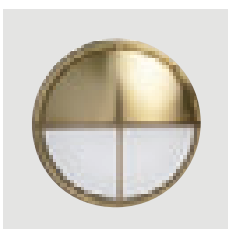

DOCKS
pag. 264

ACCENSIONI INDIPENDENTI | *INDIVIDUAL CONTROL*

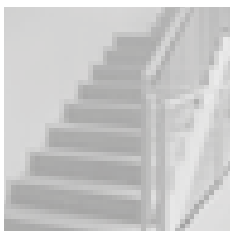

pag. 314

CURVE FOTOMETRICHE | *PHOTOMETRIC DATA*

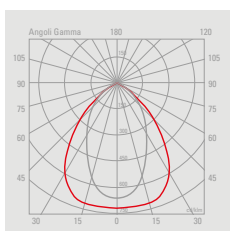

pag. 320

RICAMBI | *SPARE PARTS*

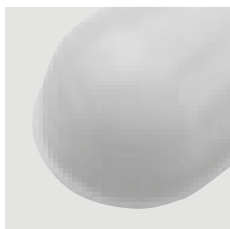

pag. 334

APPARECCHI CON REATTORE ELETTRONICO | *ELECTRONIC BALLAST VERSIONS*



pag. 335

INDICE ARTICOLI E CLASSI ENERGETICHE | *CODE INDEX AND ENERGY CLASS*

COD. CODE	SERIE RANGE	PAG. PAGE	CLASSE ENERGETICA ENERGY CLASS
B411BI	KASKO	252	A+, A, B
B411GR	KASKO	252	A+, A, B
B411SI	KASKO	252	A+, A, B
B422BI	KASKO	252	A+, A, B
B422GR	KASKO	252	A+, A, B
B422SI	KASKO	252	A+, A, B
B426BI	KASKO	252	A+, A, B
B426GR	KASKO	252	A+, A, B
B426SI	KASKO	252	A+, A, B
B428BI	KASKO	252	A+, A, B

pag. 339

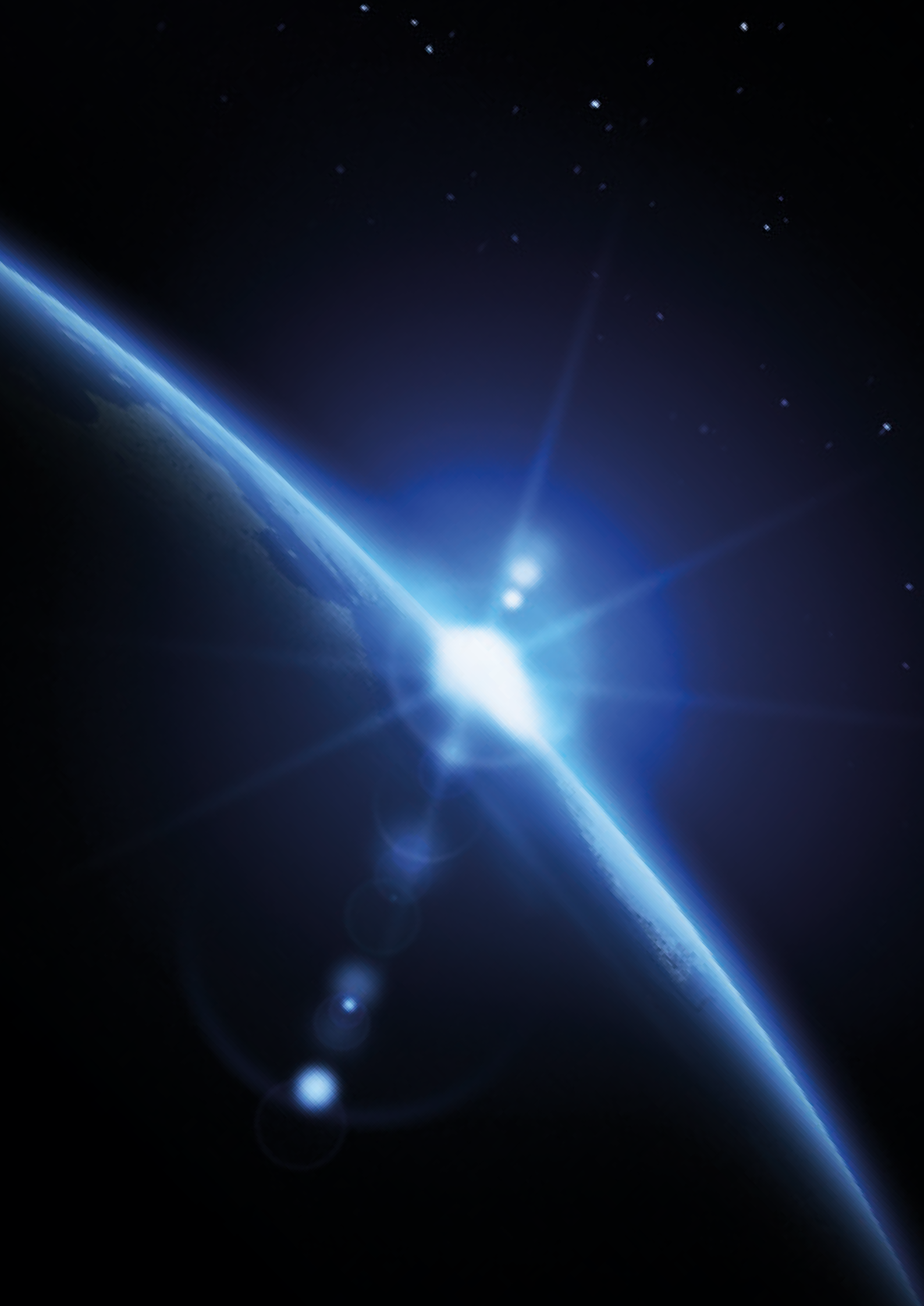

LA LUCE SECONDO GOCCIA: EMOZIONE OLTRE CHE LUMEN.

In oltre trent'anni di esperienza Goccia ha sviluppato una vera e propria filosofia della Luce. Secondo Goccia, l'illuminazione da esterni deve essere in grado di generare emozioni oltre che Lumen e di accendere l'atmosfera ideale per ogni singolo progetto. Una grande illuminazione per esterni deve sintetizzare design e funzionalità attraverso il continuo dialogo con progettisti, architetti e installatori in modo da incontrare le loro idee. Interlocutori esigenti richiedono di superare le più alte aspettative in termini di qualità e di durata in base alle quali è progettato ogni singolo apparecchio. Per Goccia, ogni luce prodotta è rappresentazione diretta della tradizione e innovazione made in Italy conosciuta e stimata nel mondo. Perché produrre illuminazione vuol dire creare emozioni.

Light according to Goccia: emotion as well as Lumen.

In its over thirty years of experience, Goccia has developed its own philosophy on Light. According to Goccia, outdoor lighting needs to generate emotion as well as Lumen, and ignite the ideal atmosphere for each individual project. Successful outdoor lighting must synthesise design and functionality through continuous dialogue with designers, architects and installers in order to meet their ideas. Demanding customers require that you exceed their highest expectations in terms of the quality and durability with which each fitting is designed. For Goccia, every light produced is a direct representation of the "Made in Italy" tradition and innovation, known and respected around the world. Because creating lighting means shedding light on illumination.





LA LUCE TUTTA ITALIANA.

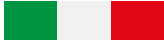

Goccia Illuminazione progetta, sviluppa e produce apparecchi per l'illuminazione da esterni costantemente aggiornati allo sviluppo tecnologico attuale. Presente da oltre trent'anni nel settore dell'illuminazione, l'Azienda vanta una produzione orgogliosamente italiana la cui affidabilità è apprezzata e richiesta in Europa e nel mondo. Negli oltre 8.000 mq di area coperta sono ideati e realizzati prodotti innovativi, adatti a diverse tipologie di utilizzo tra cui edilizia privata e pubblica, arredo urbano e costruzioni civili. L'esperienza consolidata e la precisione ne hanno fatto un classico dell'illuminazione costantemente al passo con l'evoluzione delle nuove tecnologie, Goccia è azienda certificata ISO 9002 e UNI EN ISO 9001 ed. 2008.

All-Italian lighting.

Goccia Illuminazione designs, develops and manufactures fittings for outdoor lighting, constantly updated in line with current technology development. The Company has been working in the lighting industry for over thirty years, proudly boasting an all-Italian production whose reliability is appreciated and requested around Europe and the world. We utilise our over 8,000 square metres of covered area to design and manufacture innovative products, suitable for various types of use, including private and public buildings, urban enhancement, and civil construction. Our consolidated experience and accuracy have made for lighting that is constantly in step with the evolution of new technologies. Goccia is certified ISO 9002 and UNI EN ISO 9001 ed. 2008.





DAL PROGETTO AL PRODOTTO: UN'EMOZIONE UNICA.

Il virtuale non è altro che la traduzione nella realtà di un'idea creativa, di una sensazione astratta e di una sensibilità unica che entrano a far parte del mondo dopo essere progettate in digitale. Prendono così forma solo le idee più originali e innovative, quelle che consentono alla Luce di cambiare gli equilibri interagendo con le architetture e arricchendole di dettagli togliendoli dall'ombra. Le moderne tecnologie Led sono impiegate per valorizzare superfici e volumi spaziali facendoli risaltare coerentemente con la loro funzione. Tutto questo senza tuttavia perdere mai di vista la facilità di installazione degli apparecchi, prodotti secondo le norme di tutti gli Istituti di Approvazione.

From design to final product: a unique emotion.

Virtual is nothing more than the translation into reality of a creative idea, an abstract sensation and a unique sensibility that become part of the world after be digitally designed. Only the most original and innovative ideas take form - the ones that allow Light to change balance, interacting with the architecture and enriching it with details, removing them from the shadows. Modern LED technologies are used to enhance surfaces and spatial volumes, making them stand out in accordance with their function. All this without losing the ease of installation of fittings, produced according to specifications of all Approval Institutes.

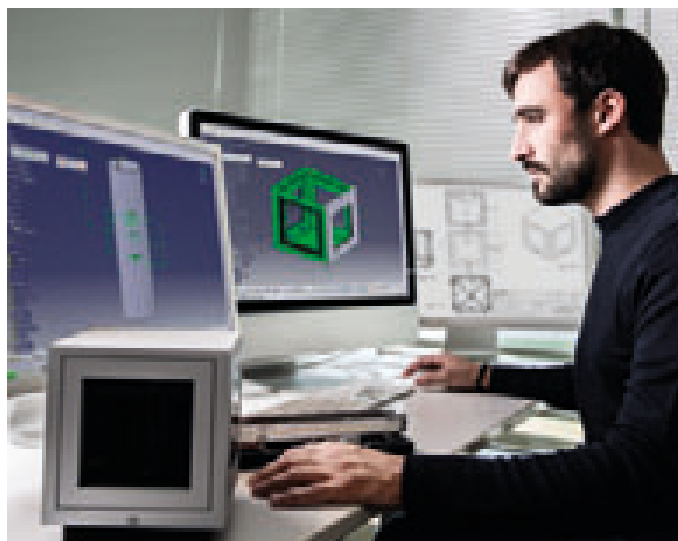

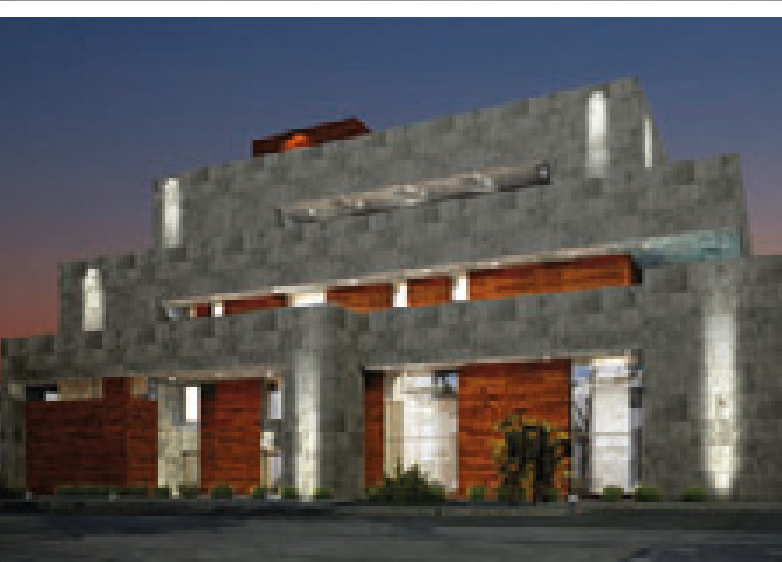

CON IL SERVIZIO ILLUMINOTECNICO GOCCIA LA LUCE PRENDE FORMA.

Grazie ai software illuminotecnici più avanzati potete dar forma alla vostra idea nella realtà virtuale sposando la nostra Luce con i vostri progetti. Goccia offre gratuitamente studi personalizzati ad hoc per una simulazione dell'intensità luminosa degli apparecchi in modo che sia correttamente applicata ai vostri progetti architettonici. Progettisti e committenti possono così visualizzare in tempo reale l'illuminazione effettiva di cui hanno bisogno.

I Servizi Illuminotecnici:

- Tutte le fotometrie Goccia, scaricabili dal sito nei formati Eulumdat, IES e FDB (richiedere password).
- Personalizzazione gratuita dello studio illuminotecnico su vostro progetto architettonico da file di qualsiasi formato, da disegno cartaceo, da fotografia del contesto.

Goccia Lighting Support: Light takes shape.

Thanks to the latest lighting software, your ideas take shape through virtual reality, matching our Light with your projects. Goccia offers free customised, ad hoc studies for light intensity simulation of the fittings so that it is properly applied to your architectural projects. Designers and customers can thus see the actual lighting they need in real time.

Lighting software services:

- *All Goccia photometry, downloaded from the website in Eulumdat, IES and FDB formats (requires password)*
- *Free customised lighting study of our architectural plan from any format files, from paper drawings, and photographs of surroundings.*



CODE 80

1.500

1.500

1.500

1.500

CERTIFICATION

CONFORMITY

CLASSIFICATION

CLASSIFICATION



TUTTE LE INFORMAZIONI A PORTATA DI CLICK.

www.goccia.it

Per fare luce sull'offerta di prodotti Goccia basta visitare il sito internet www.goccia.it, che raccoglie tutte le informazioni disponibili e i dati tecnici degli apparecchi Goccia consultabili in qualsiasi momento. I dati tecnici sono riportati in conformità alle direttive EN 60598-1:2015 mentre le schede tecniche di ogni singolo prodotto sono comodamente scaricabili in formato pdf. Ciascuna scheda è completa di descrizione per capitolato, istruzioni di montaggio, classe energetica, disegni costruttivi, disegno 3DS e curve fotometriche in modo da fornire immediatamente ai progettisti tutti i dati necessari. Oltre al sito web il Servizio Tecnico Goccia è a disposizione per informazioni o richieste personalizzate su prodotti e normative.

All the information you need, just a click away.

To shed light on Goccia products, just visit the website www.goccia.it, which gathers all available information and technical data on Goccia fittings, for consultation at any time. Technical data is reported in accordance with directives EN 60598-1:2015, while the technical data sheets of each product can be easily downloaded in pdf format. Each sheet comes complete with a description of specifications, installation instructions, energy class, construction drawings, 3DS design and photometric curves in order to immediately provide all necessary data to designers. In addition to the website, Goccia Technical Service is available for information or custom requests on products and regulations.

K' Mixed - Aluminium - 2 windows

CODE NO. 1000

LAMP LED 10x17.5W

IP 20

CLASS II

IN IP20 (20° max)

EFFICIENZA 85% (20° max)

CONFORMITÀ CE EN 60598-1:2015

ENERGY CLASS II

SPECIFICATIONS

- High performance lighting
- Highly adjustable (0-180°)
- Lightweight (Weight 0.180 kg)
- Easy installation
- LED chips for better light quality
- Lightweight design, easy handling on request
- Can be used with other accessories of 20°

DIMENSIONS

A	100 mm
B	100 mm
C	100 mm

Print created on 13/10/2015 13:35

goccia.com/technical-data
GIA (Goccia, 2015) - 02914 - Padova - 381 30g
Tel. +39 0429 210171 - Fax +39 0429 210172
www.goccia.com/technical-data

Corvina Ø 120 - 2 lights

CODE NO. 1000

LAMP LED 10x17.5W

IP 20

CLASS II

IN IP20 (20° max)

EFFICIENZA 85% (20° max)

CONFORMITÀ CE EN 60598-1:2015

ENERGY CLASS II

SPECIFICATIONS

- Lightweight and easy installation
- Minimal and compact design in line with the theme
- Highly adjustable (0-180°)
- High quality light source (LED)
- Lightweight design, easy handling on request
- Can be used with other accessories of 20°
- Lightweight design, easy handling on request
- Can be used with other accessories of 20°

DIMENSIONS

A	120 mm
B	120 mm
C	120 mm

Print created on 13/10/2015 13:35

goccia.com/technical-data
GIA (Goccia, 2015) - 02914 - Padova - 381 30g
Tel. +39 0429 210171 - Fax +39 0429 210172
www.goccia.com/technical-data

Sorgenti luminose tradizionali | Traditional light sources

Lampada Lamp	Attacco Lampholder	W	Lumen/candele	Tonalità K Tonality K	Durata h Life h	
	E27	40	400	2700	1000	
	E27	60	600			
	E27	75	900			
	E27	100	1200			
	E27	150	1600			
	E27	7	400	2700	10000	
	E27	11	600			
	E27	15	900			
	E27	20	1200			
	E27	23	1500			
	E27	30	1900			
	E27	33	2250			
	E27	50	10° 3000-3200cd 30° 1000-1100cd	3000	2000	
	E27	75	10° 6900-7500cd 30° 2200-2400cd	3000	2000	
	GU 5,3	50	10° 6900-15000cd 24° 5700cd 38° 1000-2850cd 60° 1430cd	3000	2000	
	GU 10	50	25° 1000cd	3000	2000	
		50	50° 600cd			
	GZ 10	50	25° 1000cd			
		50	50° 600cd			
	G 53	50	8° 20000-30000cd 24° 4000-5300cd	3000	3000	
		75	8° 30000cd 24° 5300cd 45° 2000cd			
		100	8° 48000cd 24° 8500cd 45° 2800cd			
	GY 6,35	50	910	3000	2000	
	G13	18	1300	2700	10000	
	G13	36	3350	3500		
	G13	58	5200	4200		
	G5	14	1300	2700	16000	
		21	2000	3000		
		28	2900	3500		
		35	3650	4200		
	G5	24	2000	2700	16000	
		39	3500	3000		
		54	5000	3500		
		80	7000	4200		
			6500	6500		
	G10q	20	900	2700	10000	
	G10q	22	1000	3500		
	G10q	32	1700	4200		
	2Gx13	22	1800	2700	16000	
		40	3200	3000		
		55	4200	3500		
			6500	4200		

Lampada Lamp	Attacco Lampholder	W	Lumen/candele	Tonalità K Tonality K	Durata h Life h
	G23	7	400	2700	8000
	G23	9	600	3500	
	G23	11	900	4200	
	2G7	7	400	2700	8000
	2G7	9	600	3500	
	2G7	11	900	4200	
	2G11	18	1200	2700	8000
	2G11	24	1800	3500	
	2G11	36	2900	4200	
	2G11	55	4800	4200	
	G24d-1	10	600	2700	8000
	G24d-1	13	900	3500	
	G24d-2	18	1200	4200	
	G24d-3	26	1800	4200	
	Gx24d-1	13	900	2700	8000
	Gx24d-2	18	1200	3500	
	Gx24d-3	26	1800	4200	
	Gx24q-1	13	900	2700	10000
	Gx24q-2	18	1200	3500	
	Gx24q-3	26	1800	4200	
	Gx24q-3	32	2400	4200	
	Gx24q-4	42	3200	4200	
	2G10	18	1100	2700	8000
	2G10	24	1700	3500	
	2G10	36	2800	4200	
	GR8	16	1050	2700	8000
	GR8	28	2050	3500	
	GR10q	10	650	2700	8000
	GR10q	16	1050	3500	
	GR10q	28	2050	4200	
	GR10q	38	2850	4200	
	R7s	100	1650	3000	2000
	R7s	150	2700		
	R7s	300	5000		
	R7s	500	9500		
	GU 6,5	20	1700	3000	8000
		35	3100	4200	
	Rx7s	70	5000	3000	8000
	Rx7s-24	150	11000	4200	
	G12	35	3300	3000	8000
		70	6600	3500	
		150	13000	4200	
	Rx7s	70	7000	2000	12000
	Rx7s-24	150	15000	4200	
	E27	50	2000	3000	12000
	E27	80	4000	3300	
	E27	125	6500	4200	
	E27	70	5000	3000	6000
	E27	150	11000	4200	
	E27	50	3500	2000	12000
	E27	70	5800		
	E40	150	14000		

Tonalità di luce

- 2000K giallo oro
- 2700K lampadina tradiz.
- 3000K tono caldo
- 3500K bianca
- 4000K bianchissima
- 6000K diurna



















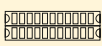

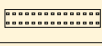
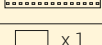











Light tonality

- 2000K gold yellow
- 2700K traditional bulb
- 3000K warm
- 3500K white
- 4000K very white
- 6000K daylight

Sorgenti luminose Led | Led light sources







Tonalità: 3000K o 4000K.

Tonality: 3000K or 4000K.

Led	W	Lumen	Driver incorporato Driver incorporated	Uscita driver Driver output	IRC CRI	Serie Range
	3,2	265 280	230V /50Hz - 12V AC/DC	350 mA	85	Quantum
 57 Led	4,2	410 430	230V /50Hz - 12V AC/DC	350 mA	85	Quantum
	19,5	1980	230V /50Hz - 12V AC/DC	350 mA	85	Compatta
	8,5	850	230V /50Hz - 12V AC/DC	24V DC	85	Compatta
	7,5	750	230V /50Hz - 12V AC/DC	500 mA	85	I-Mago
	14	1420	230V /50Hz - 12V AC/DC	240 V	85	I-Dea
	1	110	230V /50Hz - 12V AC/DC	350 mA	85	Quantum - Server Point - Passum
	8,5 17 34	850 1700 3400	230V /50Hz - 12V AC/DC	24V DC	85	Small Midi Maxi
	20/40 29/58 34/69	2000/4000 2850/5650 3400/6800	230V /50Hz - 12V AC/DC	24V DC	85	Supermaxi
	10 34,5	1000 3400	230V /50Hz - 12V AC/DC	24V DC	85	Triangolo
	39	3960	230V /50Hz - 12V AC/DC	350 mA	85	Triangolo
	9,3	1120	230V /50Hz - 12V AC/DC	500 mA	80	WASH
	11	1470	230V /50Hz - 12V AC/DC	700 mA	80	WASH
 x 1  x 2  x 4	6,4	400 800 1600	230V /50Hz - 12V AC/DC	700 mA	85	K ³ Writer
 x 1  x 2  x 4	3	185 370 740	230V /50Hz - 12V AC/DC	700 mA	85	K ³ Miniled - Corinthia - Passum Lux Shower Inside
 x 1  x 2	9,5	1200	230V /50Hz - 12V AC/DC	350 mA	85	K ³ Power - Corinthia - Passum Lux Shower Inside
	26	2640	230V /50Hz - 12V AC/DC	350 mA	85	Volto
	4	410	230V /50Hz - 12V AC/DC	350 mA	80	Passum - Lux Shower Inside
	9,5	1200	230V /50Hz - 12V AC/DC	350 mA	85	Strike 1
	29	3600	230V /50Hz - 12V AC/DC	350 mA	85	Strike 2 - Passum Lux Shower Inside
	19,5	1980	230V /50Hz - 12V AC/DC	350 mA	85	Lux Shower
	29,3	4000	230V /50Hz - 12V AC/DC	1050 mA	80	Trialo
	14	1420	230V /50Hz - 12V AC/DC	240V	80	Docks - Kasko - Jack Led
	13	1000	230V /50Hz - 12V AC/DC	240V	80	Jack Led ovale/oval
	25	2500	230V /50Hz - 12V AC/DC	500 mA	80	Feeling - Magnum
	4	480	230V /50Hz - 12V AC/DC	240V	80	Clock
	10	1000	230V /50Hz - 12V AC/DC	240V	80	Clock
	10	1000	230V /50Hz - 12V AC/DC	240V	80	Cantharellus
	20	2000	230V /50Hz - 12V AC/DC	240V	80	Cantharellus

Definizione finiture | Finish

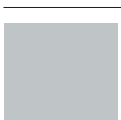
ALLUMINIO | ALUMINIUM

	Sigla Code	Colore Colours	Finitura Finish
	SI	Silver	Decapaggio + fosfocromatazione + fondo epossidico + verniciatura con polveri poliesteri + vernice trasparente di protezione e stabilizzata anti UV. <i>Pickling + phosphochrome + Epoxy basic coating + polyester powder coating + varnishing powder UV resistant.</i>
	GR	Grafite Graphite	Decapaggio + fosfocromatazione + verniciatura con polveri poliesteri stabilizzata anti UV. <i>Pickling + phosphochrome + polyester powder coating UV resistant.</i>
	BI	Bianco White	Decapaggio + fosfocromatazione + fondo epossidico + verniciatura con polveri poliesteri stabilizzata anti UV. <i>Pickling + phosphochrome + Epoxy basic coating + polyester powder coating UV resistant.</i>
	NE	Nero Black	Decapaggio + fosfocromatazione + fondo epossidico + verniciatura con polveri poliesteri stabilizzata anti UV. <i>Pickling + phosphochrome + Epoxy basic coating + polyester powder coating UV resistant.</i>
	GM	Grigio metallizzato Metallized grey	Decapaggio + fosfocromatazione + fondo epossidico + verniciatura con polveri poliesteri stabilizzata anti UV. <i>Pickling + phosphochrome + Epoxy basic coating + polyester powder coating UV resistant.</i>
	CO	Corten	Decapaggio + fosfocromatazione + fondo epossidico + verniciatura con polveri poliesteri stabilizzata anti UV. <i>Pickling + phosphochrome + Epoxy basic coating + polyester powder coating UV resistant.</i>



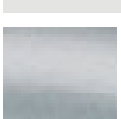



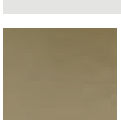

INOX | STAINLESS STEEL

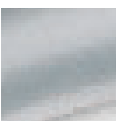
	Sigla Code	Colore Colours	Finitura Finish
	IN	Inox Stainless steel	Inox AISI 316L spazzolato e lucidato. <i>Brushed and polished AISI 316L stainless steel.</i>

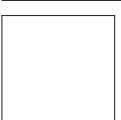
OTTONE | BRASS

	Sigla Code	Colore Colours	Finitura Finish
	OT	Ottone Brass	Ottone 60/40 pressofuso. <i>Die-cast 60/40 brass.</i>

POLICARBONATO | POLYCARBONATE

	Sigla Code	Colore Colours	Finitura Finish
	SI	Silver	Verniciatura a spruzzo con resine polieuretaniche + vernice trasparente di protezione e stabilizzata anti UV. <i>Liquid painting with polyurethanic resins + liquid varnishing UV resistant.</i>
	GR	Grafite Graphite	Verniciatura a spruzzo con resine polieuretaniche stabilizzata anti UV. <i>Liquid painting with polyurethanic and UV resistant resins.</i>
	BI	Bianco White	Stampato in pasta. <i>Colour moulded.</i>
	NE	Nero Black	Verniciatura gofrata a spruzzo con resine polieuretaniche stabilizzata anti UV. <i>Liquid textured painting with polyurethanic and UV resistant resins.</i>
	VE	Verde opalescente Opal green	Stampato in pasta opalescente. <i>Opal colour moulded.</i>
	BL	Blu opalescente Opal blue	Stampato in pasta opalescente. <i>Opal colour moulded.</i>
	AR	Arancio opalescente Opal orange	Stampato in pasta opalescente. <i>Opal colour moulded.</i>
	OP	Bianco opalescente Opal white	Stampato in pasta opalescente. <i>Opal colour moulded.</i>

Conformità normativa e Marchi di Qualità Compliance Rules and Quality Trade Marks



QUALITÀ TOTALE

Goccia Illuminazione ha ottenuto nel 1996 il riconoscimento della conformità del proprio sistema produttivo alle norme ISO 9002 e nel 2004 alle norme UNI EN ISO 9001 ed. 2008 mediante la certificazione CSQ (sistema di certificazione gestito dall'IMQ). Questa certificazione assicura all'utilizzatore finale che Goccia segue nella progettazione, nella produzione e nella commercializzazione dei prodotti precisi criteri e controlli in ottemperanza ad un proprio manuale e procedure definite. IQNET è il più grande network internazionale della certificazione dei sistemi qualità a cui aderiscono 37 organismi di certificazione. In virtù dell'accordo IQNET le aziende certificate CISQ possono avvalersi dell'attestato IQNET che conferisce validità internazionale alle certificazioni e utilizzare il logo IQNET.

GLOBAL QUALITY

In 1996 Goccia's production system was acknowledged to be in compliance with ISO 9002 standards and in 2004 in compliance with UNI EN ISO 9001 ed. 2008 standards through CSQ Certification (a system of certification controlled by IMQ). This certification assures the final customer that Goccia's products, during their production and marketing, undergo precise methods and controls, as stated in Goccia's own Quality Manual. IQNET is the biggest international network of quality system certification; this net incorporates 37 different certification organizations. Thanks to the IQNet agreement, CISQ certified companies can obtain the IQNet Certificate, which gives international validity to the certifications and allows to use the IQNet logo.



MARCATURA CE SUL PRODOTTO

Questa marcatura è obbligatoria per la libera circolazione del prodotto nella Comunità Europea e costituisce a tutti gli effetti la dichiarazione da parte del fabbricante che il prodotto è conforme alle direttive (2014/35/UE - 2014/30/UE) e quindi costruito, verificato e collaudato in conformità alle norme (sicurezza e compatibilità EMC) applicabili. La Marcatura CE non comporta controllo o garanzia alcuna da parte di istituti di certificazione volontaria (Marchi di Qualità).

CE MARK ON THE PRODUCT

This mark is compulsory for the free trade of the products within the EEC. It represents in every respect the declaration of the manufacturer that the product is in accordance with the directives (2014/35/UE - 2014/30/UE) and therefore manufactured, checked and tested in compliance with the relevant rules (Safety and EMC Compatibility). The CE mark does not require any control or warranty by any voluntary certification institute (Quality Trade Mark).



È il marchio unico europeo relativo agli apparecchi d'illuminazione. Esso può essere rilasciato ai costruttori che abbiano un Sistema Qualità certificato. In pratica l'evoluzione internazionale del Marchio IMQ.



































Is the sole European Trade Mark for illumination products and can only be applied by manufacturers such as Goccia who have a certified Quality System.



CLASSE DI PROTEZIONE | PROTECTION CLASS

	<p>IP 44</p> <p>Protetto contro la penetrazione di corpi solidi $\phi > 1\text{mm}$ e contro la pioggia. <i>Protected against solid $\phi > 1\text{mm}$ and the rain.</i></p>
	<p>IP 54</p> <p>Protetto contro la penetrazione della polvere e contro gli spruzzi d'acqua. <i>Protected against powder and water splashing.</i></p>
	<p>IP 55</p> <p>Protetto contro la penetrazione della polvere e contro i getti d'acqua. <i>Protected against powder and water jets.</i></p>
	<p>IP 65</p> <p>Stagno alla penetrazione della polvere e protetto contro i getti d'acqua. <i>Dust tight and protected against water jets.</i></p>
	<p>IP 66</p> <p>Stagno alla penetrazione della polvere e protetto contro le ondate. <i>Dust tight and protected against sea waves.</i></p>
	<p>IP 67</p> <p>Stagno alla penetrazione della polvere e idoneo all'immersione temporanea. <i>Dust tight and protected against immersion.</i></p>
	<p>Apparecchio in classe II (doppio isolamento). Non necessita di messa a terra. <i>Double insulation - Class II. Earthing not required.</i></p>
	<p>Apparecchi disponibili con tecnologia Led alta efficienza. <i>Lighting fittings Led inside.</i></p>

Icone | Icons

	Apparecchio da parete <i>Wall fitting</i>		Calpestabile <i>Walk over</i>
	Wall washer <i>Wall washer</i>		Carrabile <i>Drive over</i>
	Apparecchio da parete orientabile <i>Adjustable wall fitting</i>		Carico massimo: <i>Maximum load:</i> 1.000, 2.000, 3.500 Kg
	Apparecchio per lesene, cornicioni, capitelli <i>Fittings for pilasters, cornices, capitals</i>		Effetto Corridor <i>Corridor effect</i>
	Apparecchio sporgente da soffitto <i>Protruding ceiling fittings</i>		Illuminazione Intelligente <i>Intelligent Lighting</i>
	Apparecchio da incasso a soffitto <i>Recessed ceiling fittings</i>		Illuminazione d'emergenza <i>Emergency Lighting</i>
	Luce diretta, incasso a terra <i>Direct light, ground recessed</i>		Apparecchio a Led RGBW <i>RGBW LED fittings</i>
	Luce diretta, incasso a parete <i>Direct light, wall recessed</i>		Coppa antivandalo <i>Vandalproof diffuser</i>
	Paletti da giardino <i>Bollards for garden</i>		Vita Led 60.000h / decadimento max 20% <i>Led life 60.000 hours / max decreasing 20%</i>
	Pali da arredo urbano <i>Public posts</i>		Vita Led 50.000h / decadimento max 20% <i>Led life 50.000 hours / max decreasing 20%</i>
	Apparecchio per ombrelloni <i>Fittings for umbrellas</i>		Conformità alla norma generale: <i>According to the general standard:</i> EN 60598-1:2015 CE
	Ottica orientabile, incasso a terra/parete <i>Adjustable, recessed ground/wall optics</i>		Conformità alla norma per calpestabili: <i>According to in-ground recessed lighting fittings standard:</i> EN 60598-2-13:2006+A1:2012 CE
	Ottica basculante ± 15° <i>± 15° tilting optics</i>		Conformità alla norma per lamade da emergenza: <i>According to emergency lights standard:</i> EN 60598-2-22:2014 CE
	Ottica basculante ± 25° <i>± 25° tilting optics</i>		Conformità alla norma per apparecchi fissi: <i>According to fix lighting installation standard:</i> EN 60598-2-1:1989 CE
	Apparecchio non installabile a soffitto <i>Fitting cannot be installed on ceiling</i>		Conformità alla norma per apparecchiature assiemate/quadri elettrici: <i>According to power points standard:</i> EN 61439-1:2011 CE
	Driver incorporato <i>Driver inside</i>		Conformità alla norma per apparecchi da incasso: <i>According to wall/ceiling recessed lights standard:</i> EN 60598-2-2:2012 CE
	Driver remoto per collegamento in serie <i>Remote driver for series connection</i>		Conformità alla norma per apparecchi mobili: <i>According to removable lightings standard:</i> EN 60598-2-4:1997 CE
	Temperatura di contatto sul vetro T ≤ 40°C <i>Contact temperature on glass T ≤ 40°C</i>		Conformità alla norma per pali da arredo urbano: <i>According to urban areas lighting columns standard:</i> EN 40-6:2002 CE
			Apparecchi con reattore elettronico <i>Electronic ballast versions</i>

INDICE PER FAMIGLIE DI PRODOTTO PRODUCT RANGES SUMMARY

INDICAZIONI PER LA CONSULTAZIONE DEL CATALOGO INSTRUCTIONS FOR CONSULTING THE CATALOGUE

QUANTUM	pag. 24
PASSUM	pag. 52
STANDING	pag. 78
COMPATTA	pag. 82
CANTHARELLUS	pag. 92
I-LUX	pag. 98
I-MAGO	pag. 106
I-DEA	pag. 112
SERVER POINT	pag. 118
SMALL, MIDI, MAXI & SUPERMAXI	pag. 124
TRIANGOLO	pag. 140
TRIANGOLO CITY	pag. 152
WASH	pag. 158
K ³ WRITER	pag. 172
K ³ MINILED	pag. 180
K ³ POWER	pag. 188
CORINTHIA	pag. 196
VOLTO	pag. 206
CLOCK	pag. 212
STRIKE	pag. 220
LUX SHOWER	pag. 234
LUX SHOWER INSIDE	pag. 240
RGB LED	pag. 246
TRIALO	pag. 252
DOCKS	pag. 256
KASKO	pag. 266
FEELING	pag. 278
JACK	pag. 290
JACK LED	pag. 294
MARINA	pag. 298
MAGNUM	pag. 306
SUMMERTIME	pag. 310
ACCENSIONI INDIPENDENTI INDIVIDUAL CONTROL	pag. 314

CODE	LAMP	W	lm Nominali - Real output		Codice colore 1 Colour code 1	Codice colore 2 Colour code 2
1321*	Led	2x9,3	2x1120	2x950	GR	SI
	Aggiungere il codice colore Add the colour code	Watt	Lumen reali Actual Lumen			
	Codice articolo Item code		Lumen nominali Nominal Lumen			

La sequenza corretta per comporre il codice d'ordine è la seguente:
The code number combination system is:

Codice articolo
Item code

Tonalità*
Tonality*

1321GR3K

Codice colore
Colour code

* Le tonalità disponibili per i Led sono 3000K o 4000K, il codice è **3K** o **4K**.
Per le aperture dei fasci luminosi in option, aggiungere l'angolo al codice.

* The led color temperature available are 3000K and 4000K. Code **3K** and **4K**.
For the optional angle beam available add the angle to the code.



QUANTUM

LAMPADE DA INCASSO A PARETE A TENUTA STAGNA WATERTIGHT WALL RECESSED LAMPS

La Serie QUANTUM di apparecchi da incasso a tenuta stagna è stata progettata intorno ai più avanzati Led di potenza. La concezione innovativa del sistema ha consentito di inserire, in un corpo di dimensioni ridotte, il generoso dissipatore con trasformatore 230 V/12V che consente di collegare QUANTUM alla normale linea 230 V. La massima componibilità del progetto, permette di rivestire il corpo lampada con maschere di diverso disegno e materiali. L'aggancio a scatto (assicurato da due viti esagonali) facilita l'installazione. Le lampade si installano sia nelle comuni scatole per interni (da 3, 4 o 6 moduli) che nelle speciali controcasse Goccia dedicate. La Serie QUANTUM è completata da pali e piantane per illuminare percorsi pedonali, scale, piste ciclabili, parchi e giardini.

The QUANTUM Series of watertight wall recessed fittings has been designed around the most advanced power LEDs. The innovative system concept allows for the insertion of a generous diffuser with 230 V/12V transformer inside a compact body, to connect the QUANTUM to the normal 230 V line. The maximum modularity of the design allows the lamp body to be dressed with different design and material masks. The snap connection (secured with two hex screws) facilitates installation. The lamps are installed in special Goccia backboxes for outdoor installation. The QUANTUM Series is completed with posts to light pedestrian routes, stairs, bike paths, parks and gardens.







QUANTUM

Lampade da incasso a parete a tenuta stagna
Watertight wall recessed lamps

Brevetto depositato
Registered patent



Alluminio
Aluminium
LED



Inox 316 L
Stainless steel 316 L
LED



Vetro piano temprato
Flat tempered glass
LED



QUANTUM pali/posts



Palo
Post
LED



Piantana
Post
LED



Palo basso
Small garden post
LED



QUANTUM

Lampade da incasso a parete a tenuta stagna
Watertight wall recessed lamps

CARATTERISTICHE GENERALI

- Serie di apparecchi da incasso a muro per esterni.
- **Struttura:** controcassa 503/504/506 di mercato o specifica Goccia chiusa con coperchio. Corpo lampada in policarbonato. Maschera di copertura in policarbonato, alluminio, inox o vetro.
- Incastro snapping della maschera sul corpo con ritenzione di sicurezza mediante viti a brugola inox in tinta.
- Luce diffusa ed uniforme con varie aperture del fascio luminoso.
- Ingresso cavi laterale. Cablaggio passante consentito. Driver incorporato.
- Numerosi accessori consentono l'utilizzo su palo e per installazione sporgente a parete. Un sistema canale consente di duplicare i punti luce partendo da una sola semplice alimentazione.
- Led di nuova generazione ad alto rendimento.
- Vita garantita: 60.000 ore con successivo scadimento max del 20%
- **Finitura per alluminio:** decappaggio + fosfocromatazione + fondo epossidico + verniciatura con polveri epossidiche stabilizzata anti UV
- Costruito in conformità alle norme europee EN 60598-1:2015 **CE**

GENERAL FEATURES

- *Series of wall recessed fittings for outdoors.*
- **Structure:** *Goccia closed backbox with cover. Polycarbonate lamp body. Polycarbonate, aluminium, stainless steel or glass covering mask.*
- *Mask snap connection on body with safety retention with stainless steel matching Allen key screws.*
- *Diffused, even light with various angle beam openings.*
- *Side cable entry. Through wiring permitted. Driver inside.*
- *A large range of accessories allows use on posts and protruding wall installation. A conduit system allows you to duplicate points of lights starting from a single power supply.*
- *New generation high performance LEDs.*
- *Minimum life: 60,000 hours with subsequent deterioration max 20%*
- **Finish for aluminium:** *pickling + phosphochrome + epoxy basic coating + UV resistant stabilised epoxy powder coating.*
- *Manufactured in compliance with European standards EN 60598-1:2015 **CE***

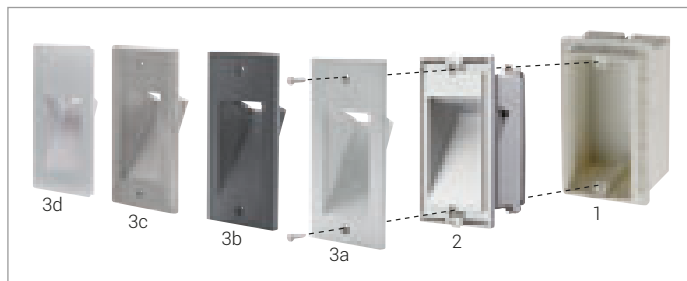

MASSIMA COMPONIBILITÀ

La Serie Quantum, totalmente componibile, è composta da:

- 1 - controcasse dedicate o controcasse comuni per interni
- 2 - corpi lampada a Led, a 3/4/6 Moduli standard
- 3 - maschere intercambiabili in alluminio (3a), policarbonato (3b), INOX 316L (3c), vetro opale (3d).

MAXIMUM MODULARITY

The lighting fittings of the range are supplied in 3 separate parts:

- 1 - Recessing box
- 2 - Light body with glass and gasket
- 3 - Changeable flanges

DIMENSIONI RIDOTTE

Goccia ha inserito in un corpo di dimensioni ridotte un Led ad alta efficienza e un trasformatore da 230 a 12 V con un potente dissipatore.

SMALL DIMENSIONS

Goccia has inserted a high efficiency LED and a transformer from 230 to 12 V with a powerful diffuser inside a compact body.

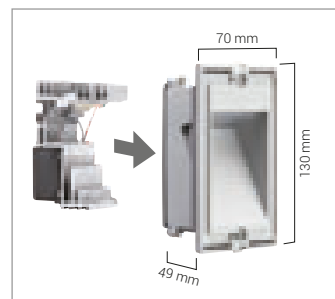

TECNOLOGIA LED AD ALTA EFFICIENZA

Led con elevatissima efficienza luminosa ed elevato indice di resa cromatica **CRI 85**.

HIGH EFFICIENCY LED TECHNOLOGY

Very high lighting efficiency LEDs with high colour rendering index CRI 85.

Watt	Lumen	Tonalità Tonality
2	190	3000K/4000K
3,2	265	3000K/4000K
4,2	410	3000K/4000K

Sicurezza fotobiologica: gruppo di rischio 0 in accordo alla norma EN 62471:08.*
 Photobiologic safety: risk group 0 standard EN 62471:08.*

^{*)} Test eseguito presso l'Istituto IMQ.
^{*)} Test run at IMQ Institute.

LA GIUSTA LUCE

Le particolari forme degli apparecchi permettono di distribuire la luce verso il basso o frontalmente offrendo un'ampia gamma illuminotecnica.

- 1 - Luce frontale
- 2 - Luce verso il basso

THE RIGHT LIGHT

The particular shapes of the fittings allow you to distribute light downward or frontally, offering a wide lighting range.

- 1 - Front light
- 2 - Downward light

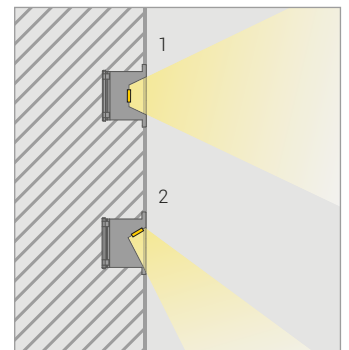

INSTALLAZIONE A SPORGERE

I contenitori a sporgere, frontali (1) o wall washer (2), consentono l'installazione di Quantum anche su pareti finite o non incassabili. Il canale portacavi in alluminio permette di alimentare più corpi lampada senza incasso.

PROTRUDING INSTALLATION

Front (1) or wall washer (2) protruding containers allow for Quantum installation also on finished or where you cannot recess. The aluminium cable trunking allows you to power more than one lamp body without recessing.

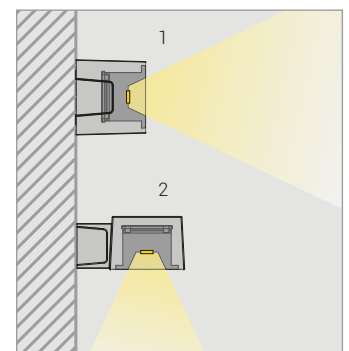

INSTALLAZIONE DA GIARDINO

I pali e le piantane consentono di installare gli apparecchi Quantum anche in giardini e camminamenti (vedi pagg. 46, 48, 50). I pali alti consentono di orientare la luce verso il basso o frontalmente.

GARDEN INSTALLATION

Posts allow for Quantum fitting installation also in gardens and walkways (see pages 46, 48, 50). Tall posts allow you to direct light downward or frontally.

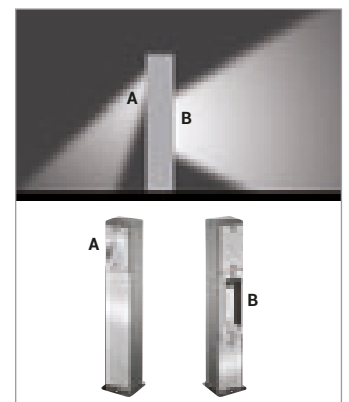













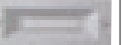

QUANTUM

Lampade da incasso a parete a tenuta stagna
Watertight wall recessed lamps

TABELLA DELLA COMPONIBILITÀ | MODULARITY

Corpi lampada Light bodies	Controcasse Backboxes	Maschere - Masks							Materiali Materials
									
1 W 	4 MOD.	■							Policarbonato Polycarbonate
		■							Alluminio Aluminium
		■							Inox Stainless steel
		■							Vetro Glass
3,2 W 	4 MOD.	■							Policarbonato Polycarbonate
		■							Alluminio Aluminium
		■							Inox Stainless steel
		■							Vetro Glass
2 W 	3 MOD.		■						Policarbonato Polycarbonate
									Alluminio Aluminium
			■						Inox Stainless steel
				■					Vetro Glass
3,2 W 	4 MOD.			■					Policarbonato Polycarbonate
				■					Alluminio Aluminium
				■					Inox Stainless steel
				■					Vetro Glass
4,2 W 	6 MOD.				■				Policarbonato Polycarbonate
					■				Alluminio Aluminium
					■				Inox Stainless steel
					■				Vetro Glass
4,2 W 	6 MOD.					■			Policarbonato Polycarbonate
						■	■		Alluminio Aluminium
						■	■		Inox Stainless steel
								■	

QUANTUM

Lampade da incasso a parete a tenuta stagna
Watertight wall recessed lamps



CORPO LAMPADA 4 MOD. | LIGHT BODY 4 MOD.

Code + Tonality

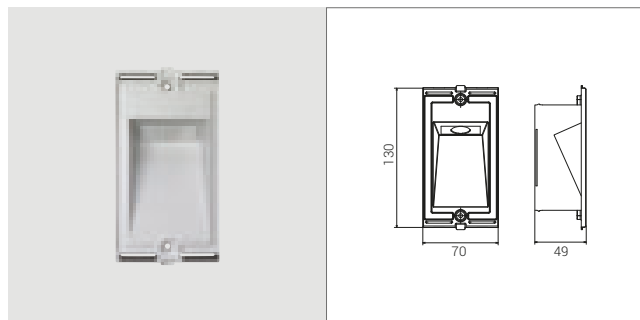

CODE	LAMP	W	lm Nominali-Real output	
5421	Led	1	105	51

A montare su scatola 4 moduli o cod. 5481.
IP 65 / Classe II / IK 10
CRI 85 / Driver IN / 350 mA
230V / 50 Hz / 12V a richiesta

Tonalità 3000K o 4000K.
Aggiungere 3K o 4K dopo il codice.

To be installed on the backbox cod. 5481.
IP 65 / Class II / IK 10
CRI 85 / Driver IN / 350 mA
230V / 50 Hz / 12V on request

Color temperature available 3000K or 4000K. Add 3K or 4K to the code.

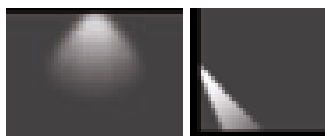

Code + Tonality

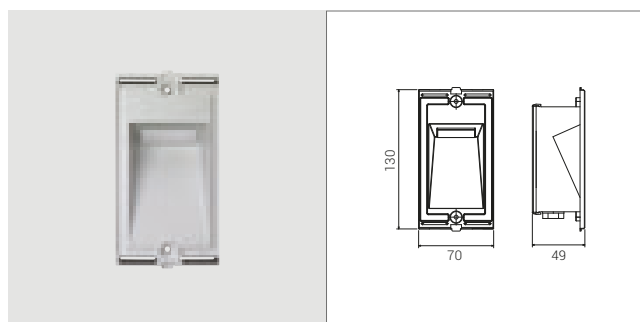

CODE	LAMP	W	lm Nominali-Real output	
5425	Led	3,2	265	168

A montare su scatola 4 moduli o cod. 5481.
IP 65 / Classe II / IK 10
CRI 85 / Driver IN / 350 mA
230V / 50 Hz / 12V a richiesta

Tonalità 3000K o 4000K.
Aggiungere 3K o 4K dopo il codice.

To be installed on the backbox cod. 5481.
IP 65 / Class II / IK 10
CRI 85 / Driver IN / 350 mA
230V / 50 Hz / 12V on request

Color temperature available 3000K or 4000K. Add 3K or 4K to the code.



CORPO LAMPADA 3 MOD. | LIGHT BODY 3 MOD.

Code + Tonality

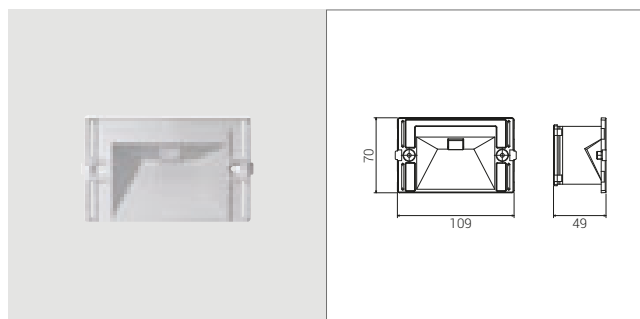

CODE	LAMP	W	lm Nominali-Real output	
5420	Led	2	190	92

A montare su scatola 3 moduli o cod. 5480.
IP 65 / Classe II / IK 10
CRI 85 / Driver IN / 350 mA
230V / 50 Hz / 12V a richiesta

Tonalità 3000K o 4000K.
Aggiungere 3K o 4K dopo il codice.

To be installed on the backbox cod. 5480.
IP 65 / Class II / IK 10
CRI 85 / Driver IN / 350 mA
230V / 50 Hz / 12V on request

Color temperature available 3000K or 4000K. Add 3K or 4K to the code.





CORPO LAMPADA 4 MOD. | LIGHT BODY 4 MOD.

Code + Tonality

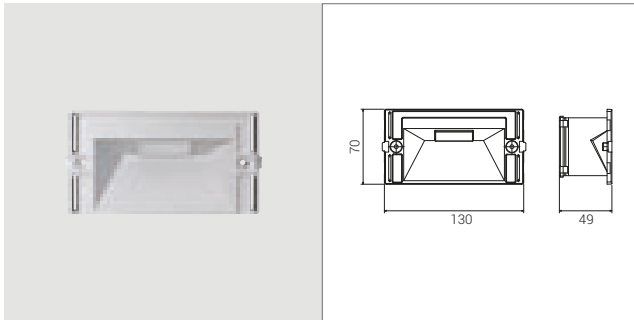

CODE	LAMP	W	Im	Nominali-Real output
5430	Led	3,2	265	168

A montare su scatola 4 moduli o cod. 5481.
 IP 65 / Classe II / IK 10
 CRI 85 / Driver IN / 350 mA
 230V / 50 Hz / 12V a richiesta

Tonalità 3000K o 4000K.
Aggiungere 3K o 4K dopo il codice.

To be installed on the backbox cod. 5481.
IP 65 / Class II / IK 10
CRI 85 / Driver IN / 350 mA
230V / 50 Hz / 12V on request

Color temperature available 3000K or 4000K. Add 3K or 4K to the code.

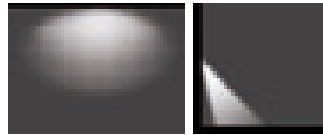

CORPO LAMPADA 6 MOD. | LIGHT BODY 6 MOD.

Code + Tonality

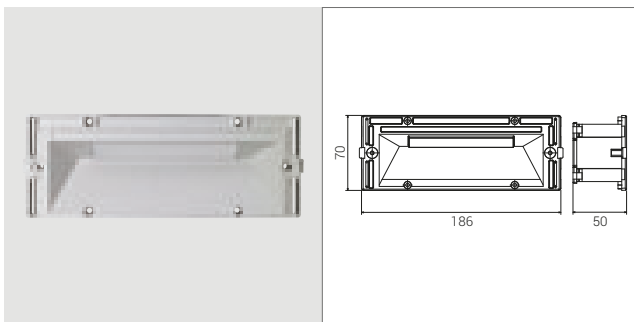

CODE	LAMP	W	Im	Nominali-Real output
5435	52 Led	4,2	410	260

A montare su scatola 6 moduli o cod. 5482.
 IP 65 / Classe II / IK 10
 CRI 85 / Driver IN / 350 mA
 230V / 50 Hz / 12V a richiesta

Tonalità 3000K o 4000K.
Aggiungere 3K o 4K dopo il codice.

To be installed on the backbox cod. 5482.
IP 65 / Class II / IK 10
CRI 85 / Driver IN / 350 mA
230V / 50 Hz / 12V on request

Color temperature available 3000K or 4000K. Add 3K or 4K to the code.

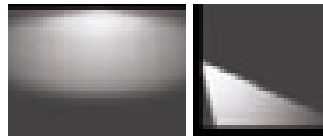

Code + Tonality

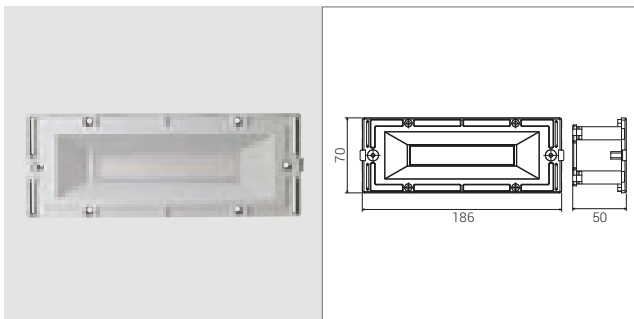

CODE	LAMP	W	Im	Nominali-Real output
5440	52 Led	4,2	410	309

A montare su scatola 6 moduli o cod. 5482.
 IP 65 / Classe II / IK 10
 CRI 85 / Driver IN / 350 mA
 230V / 50 Hz / 12V a richiesta

Tonalità 3000K o 4000K.
Aggiungere 3K o 4K dopo il codice.

To be installed on the backbox cod. 5482.
IP 65 / Class II / IK 10
CRI 85 / Driver IN / 350 mA
230V / 50 Hz / 12V on request

Color temperature available 3000K or 4000K. Add 3K or 4K to the code.



QUANTUM

Lampade da incasso a parete a tenuta stagna
Watertight wall recessed lamps

CONTROCASSA | BACKBOX

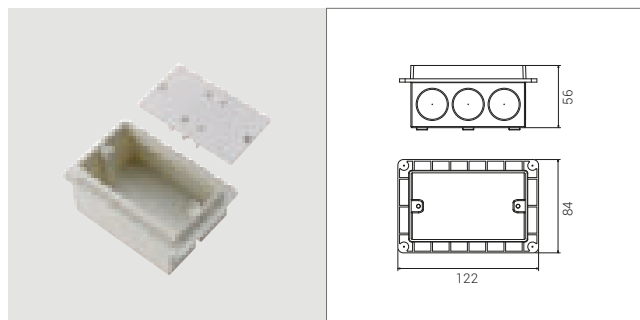

CODE DESCRIZIONE / DESCRIPTION

5480 Per corpi / For bodies
5420

Interassi di fissaggio come scatola 3 moduli.
Completa di coperchio.

Cover included.

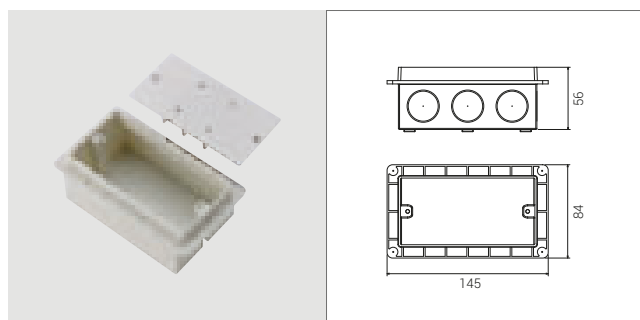

CODE DESCRIZIONE / DESCRIPTION

5481 Per corpi / For bodies
5421-5425-5430

Interassi di fissaggio come 4 moduli.
Completa di coperchio.

Cover included.

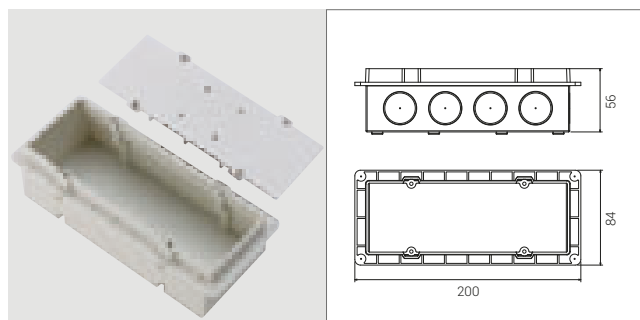

CODE DESCRIZIONE / DESCRIPTION

5482 Per corpi / For bodies
5435-5440

Interassi di fissaggio come 6 moduli.
Completa di coperchio.

Cover included.

FILTRI COLORATI | DICHOIC FILTERS

Code + Colour



CODE DESCRIZIONE / DESCRIPTION

AR VE BL

5483* Per corpi / For bodies
5420

5484* Per corpi / For bodies
5421-5425

5485* Per corpi / For bodies
5430

5486* Per corpi / For bodies
5435

5487* Per corpi / For bodies
5440

Gelatine Lee-filter sagomate.

Lighting filters.

QUANTUM

MASCHERA POLICARBONATO | POLYCARBONATE MASK

Code + Colour

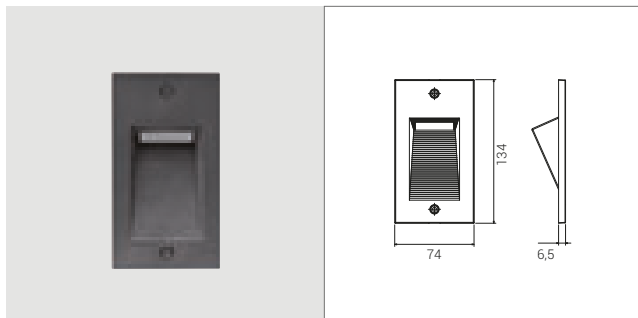

CODE DESCRIZIONE / DESCRIPTION

GR

5452* Per corpi / For bodies
5421-5425

Maschera di rivestimento in polycarbonato.
Bloccaggio a scatto + viti inox di sicurezza.

*Covering masks in polycarbonate.
Snap fastener + security screws.*

Code + Colour

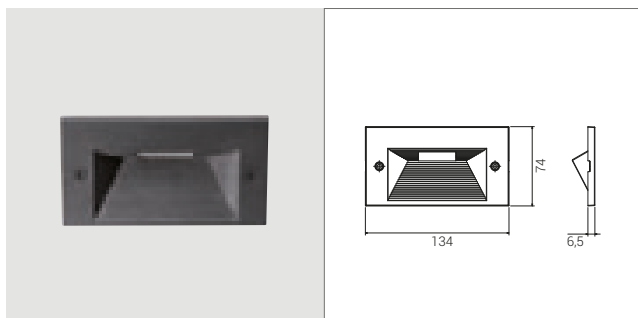

CODE DESCRIZIONE / DESCRIPTION

GR

5453* Per corpi / For bodies
5430

Code + Colour

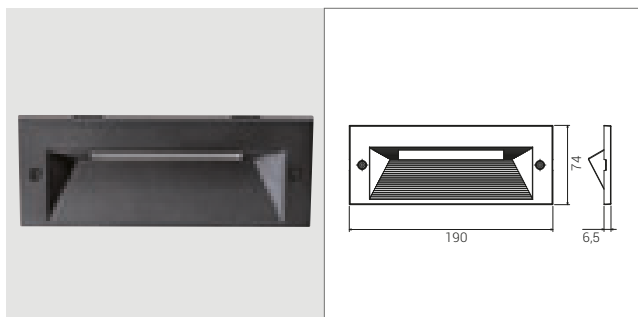

CODE DESCRIZIONE / DESCRIPTION

GR

5454* Per corpi / For bodies
5435

Code + Colour

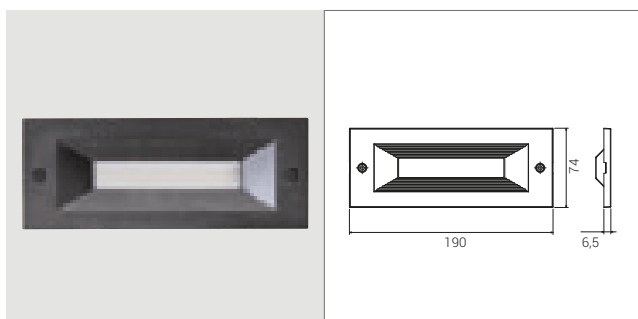

CODE DESCRIZIONE / DESCRIPTION

GR

5455* Per corpi / For bodies
5440

QUANTUM

Lampade da incasso a parete a tenuta stagna
Watertight wall recessed lamps

MASCHERA ALLUMINIO | ALUMINIUM MASK

Code + Colour

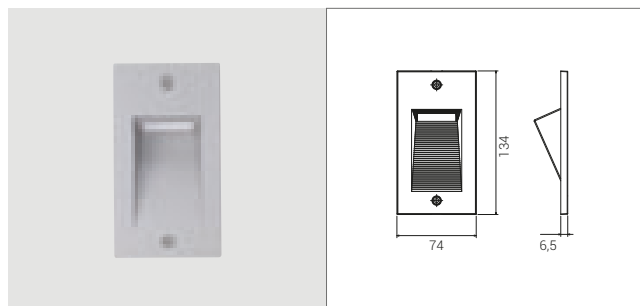

CODE DESCRIZIONE / DESCRIPTION

GR GM BI

5462* Per corpi / For bodies
5421-5425

Maschera di rivestimento in alluminio pressofuso.
Bloccaggio a scatto + viti inox di sicurezza.
Verniciatura a polvere dopo fosfocromatazione stabilizzata raggi UV.
Colore Corten a richiesta.

*Covering masks in die-cast aluminium.
Snap fastener + security screws.
Pre-phosphochromed UV resistant painting.
Corten colour available upon request.*

Code + Colour

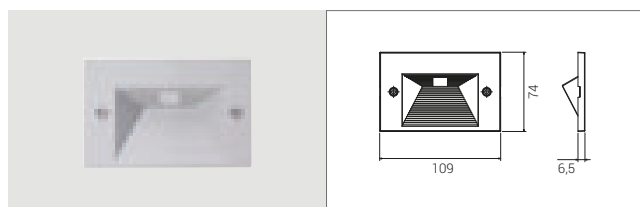

CODE DESCRIZIONE / DESCRIPTION

GR GM BI

5460* Per corpi / For bodies
5420

Code + Colour

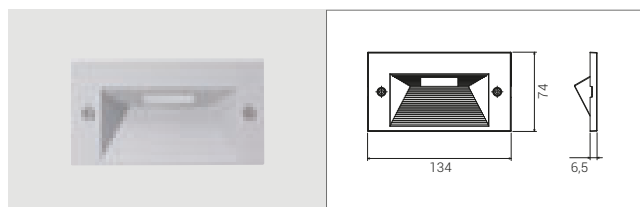

CODE DESCRIZIONE / DESCRIPTION

GR GM BI

5463* Per corpi / For bodies
5430

Code + Colour

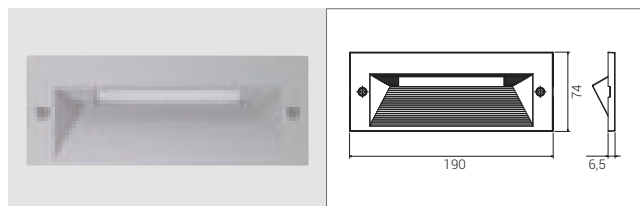

CODE DESCRIZIONE / DESCRIPTION

GR GM BI

5464* Per corpi / For bodies
5435

Code + Colour

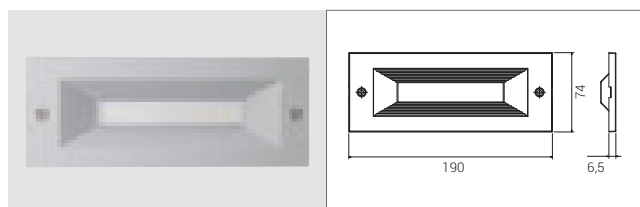

CODE DESCRIZIONE / DESCRIPTION

GR GM BI

5465* Per corpi / For bodies
5440

Code + Colour

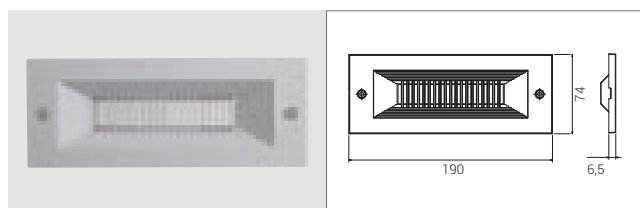

CODE DESCRIZIONE / DESCRIPTION

GR GM BI

5466* Per corpi / For bodies
5440

Code + Colour

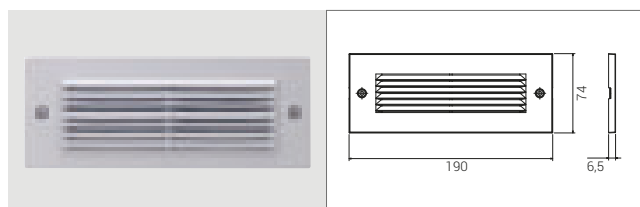

CODE DESCRIZIONE / DESCRIPTION

GR GM BI

5467* Per corpi / For bodies
5440

MASCHERA INOX | STAINLESS STEEL MASK

Code + Colour

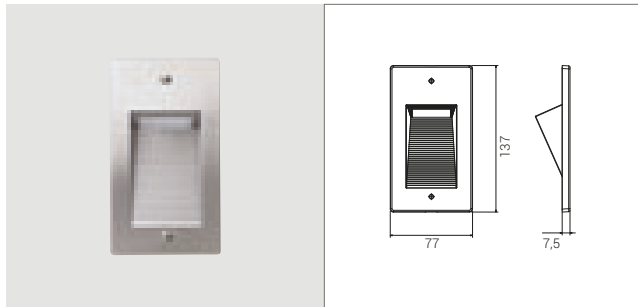

CODE DESCRIZIONE / DESCRIPTION

IN

5472* Per corpi / For bodies
5421-5425

Maschera di rivestimento in inox 316 L.
Bloccaggio a scatto + viti inox di
sicurezza.
Finitura superficiale con satinatura
opaca.

*Covering masks in stainless steel 316 L.
Snap fastener + security screws.
Brushed and satin matt surface.*

Code + Colour

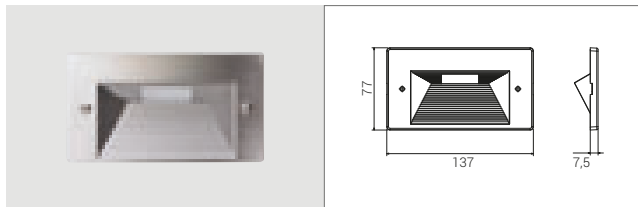

CODE DESCRIZIONE / DESCRIPTION

IN

5473* Per corpi / For bodies
5430

Code + Colour

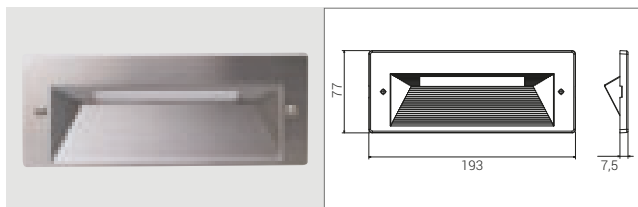

CODE DESCRIZIONE / DESCRIPTION

IN

5474* Per corpi / For bodies
5435

Code + Colour

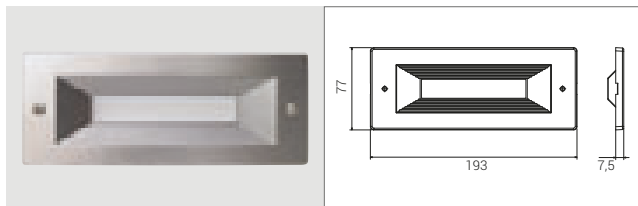

CODE DESCRIZIONE / DESCRIPTION

IN

5475* Per corpi / For bodies
5440

Code + Colour

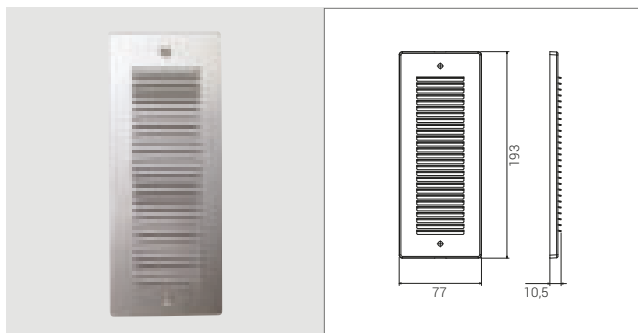

CODE DESCRIZIONE / DESCRIPTION

IN

5476* Per corpi / For bodies
5440

Code + Colour

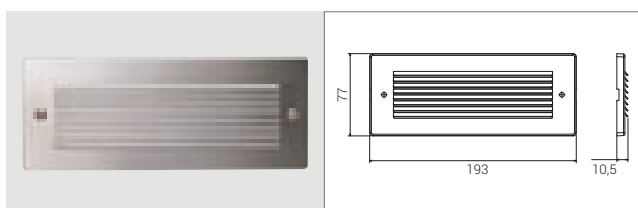

CODE DESCRIZIONE / DESCRIPTION

IN

5477* Per corpi / For bodies
5440

QUANTUM

Lampade da incasso a parete a tenuta stagna
Watertight wall recessed lamps

MASCHERA VETRO | GLASS MASK

Code+ Colour

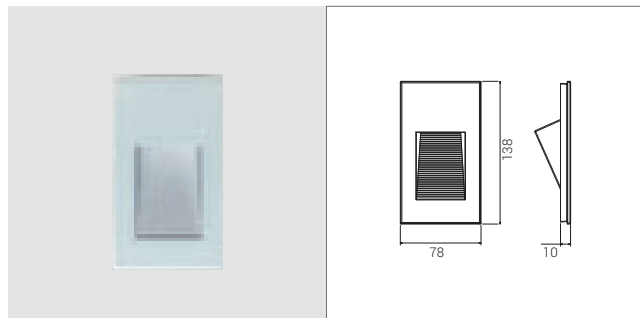

CODE DESCRIZIONE / DESCRIPTION OP

5441* Per corpi / For bodies
5421-5425

Maschera di rivestimento in vetro piano
temprato.
Bloccaggio a scatto senza viti a vista.
Finitura opale a disegno con piano
inclinato bianco a vista.

*Covering masks in flat tempered glass.
Snap fastener - no security screws.
Opal finish on the glass and inclined plan
in white.*

Code+ Colour

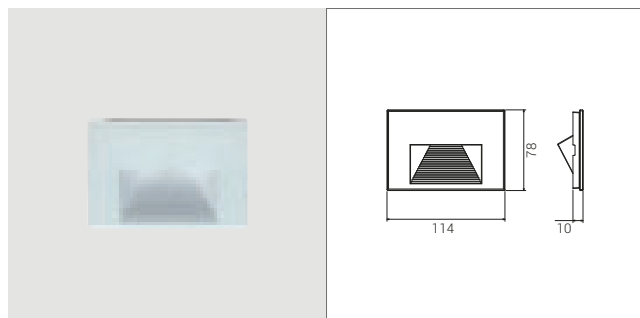

CODE DESCRIZIONE / DESCRIPTION OP

5442* Per corpi / For bodies
5420

Code+ Colour

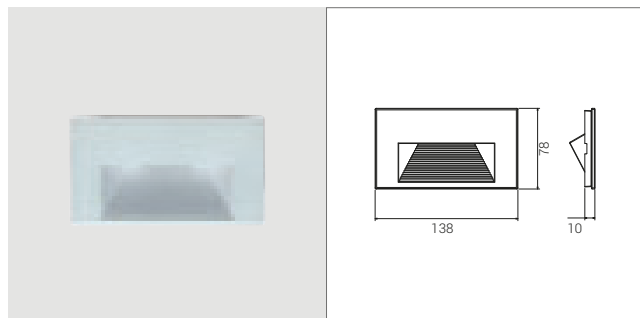

CODE DESCRIZIONE / DESCRIPTION OP

5443* Per corpi / For bodies
5430

Code+ Colour

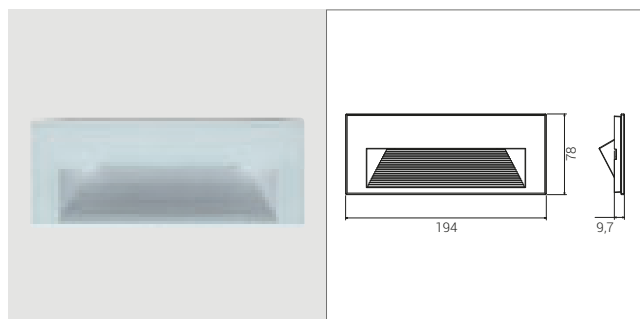

CODE DESCRIZIONE / DESCRIPTION OP

5444* Per corpi / For bodies
5435

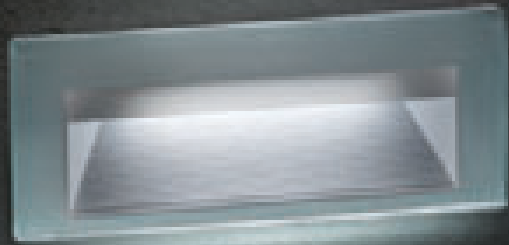

QUANTUM

Contenitori per installazione sporgente a parete
Containers for protruding wall installation

CONTENITORE SPORGENTE | EXTERNAL BOX

Code + Colour

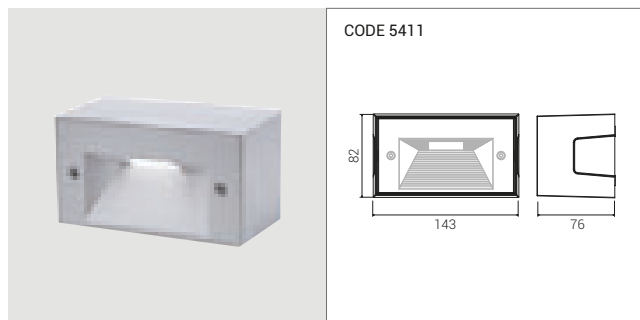

CODE DESCRIZIONE / DESCRIPTION

GR GM

5411* Per corpi / For bodies
5430

5412* Per corpi / For bodies
5435-5440

Corpo in alluminio verniciato a polvere poliestere dopo fosfocromatazione stabilizzata raggi UV.
Predisposto per contenere corpo lampada e relativa maschera.
Ingresso cavi $\varnothing 14$ laterale o dal retro.
Idoneo per cablaggio passante.
Morsettieria entra/esci incorporata.
CE

Aluminium body with pre-phosphochrome + UV resistant coating.
Made to contain light body and its mask.
Rear or side cable entry. Suitable to 14 mm \varnothing wiring. Through wiring allowed.
Terminal block incorporated.
CE

Solo contenitore. Apparecchio Quantum fornito a parte.

Box only. Quantum fitting supplied separately.

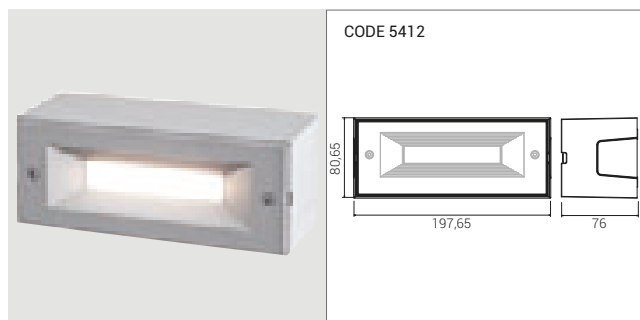

Luce orientabile in basso, con corpo lampada 5430-5435.
Box + 5430-5435 downwards oriented.

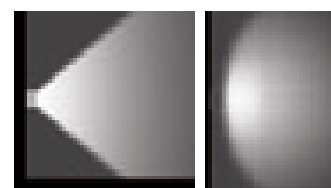

Luce frontale, con corpo lampada 5440.
Box + 5440 outwards oriented.

CONTENITORE WALL WASHER | WALL WASHER BOX

Code + Colour

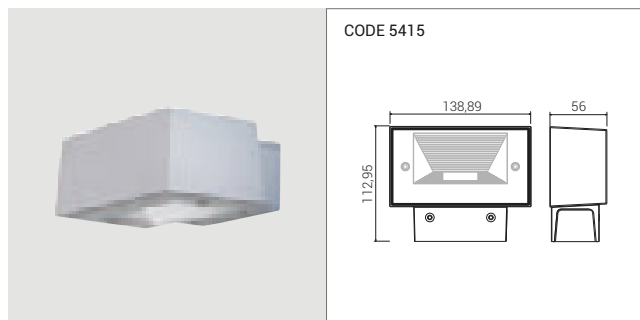

CODE DESCRIZIONE / DESCRIPTION

GR GM

5415* Per corpi / For bodies
5430

5416* Per corpi / For bodies
5435-5440

Struttura e altre caratteristiche: vedi cod. 5411.
I corpi 5435 possono essere montati verso l'esterno o verso il muro.

Features as code 5411.
The bodies 5435 can be outwards or wallwards oriented.

Solo contenitore. Apparecchio Quantum fornito a parte.

Box only. Quantum fitting supplied separately.

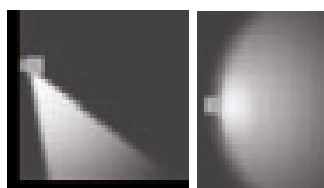
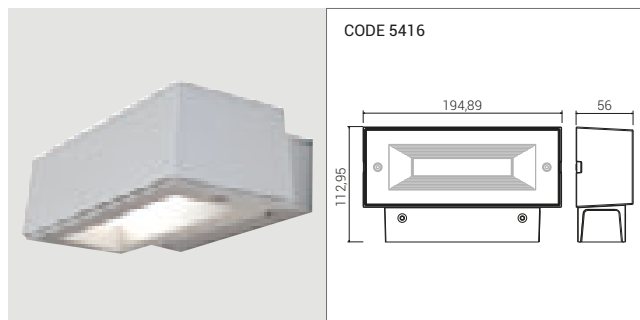

Luce in avanti, con corpo lampada 5430-5435.
Box + 5430-5435 outwards/wallwards oriented.

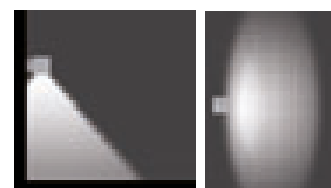

Luce in basso, con corpo lampada 5440.
Box + 5440 downwards oriented.



QUANTUM

Sistema portacavi per installazione sporgente a parete
Cable trunking system for protruding wall installation

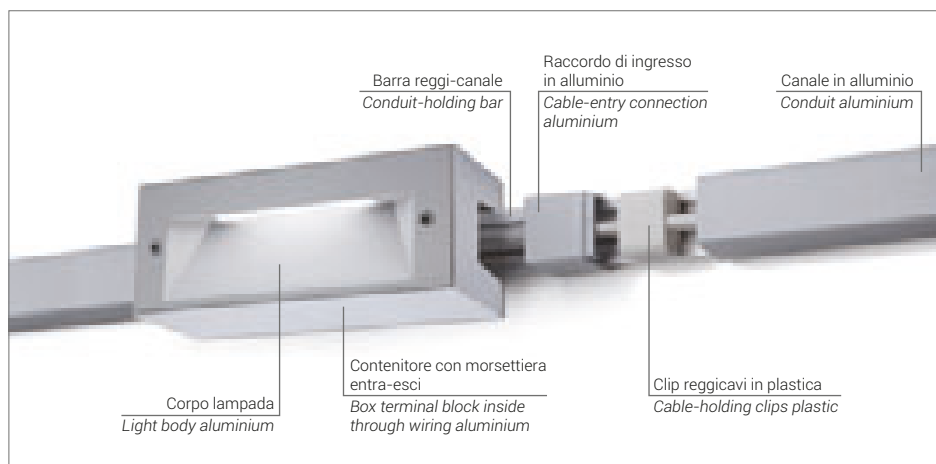

Il Sistema Portacavi con canale antivandalo, completamente in alluminio, consente di alimentare numerosi corpi lampada con il contenitore sporgente o wall washer con un unico punto luce. È possibile così installare punti luce anche su superfici difficilmente incassabili o già esistenti.

The vandal-proof cable trunking, completely in aluminium, allows to give power to many lights starting from only one light point. Suitable to hold the external or the wall-washer boxes. In this way you can bring the light where you cannot recess a backbox or where the wall already is existing.

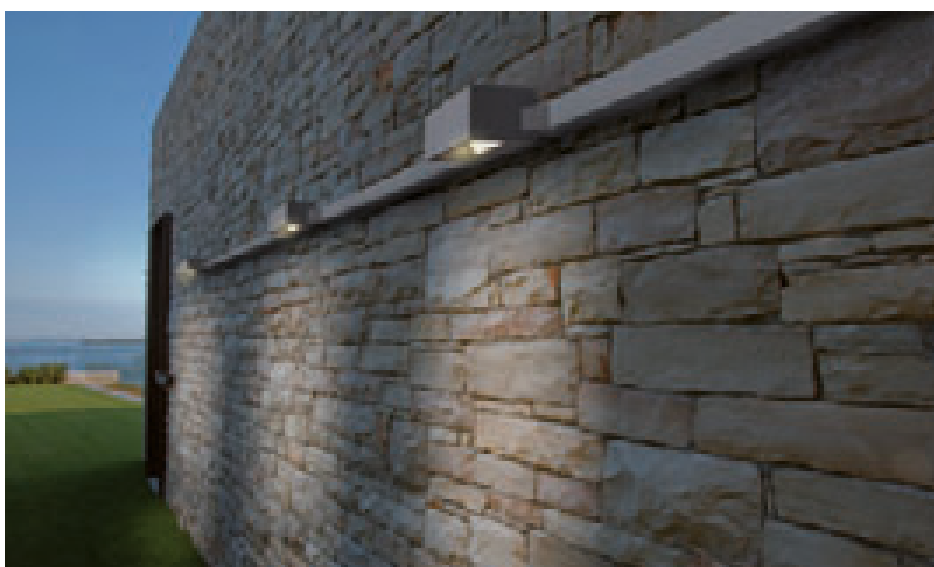
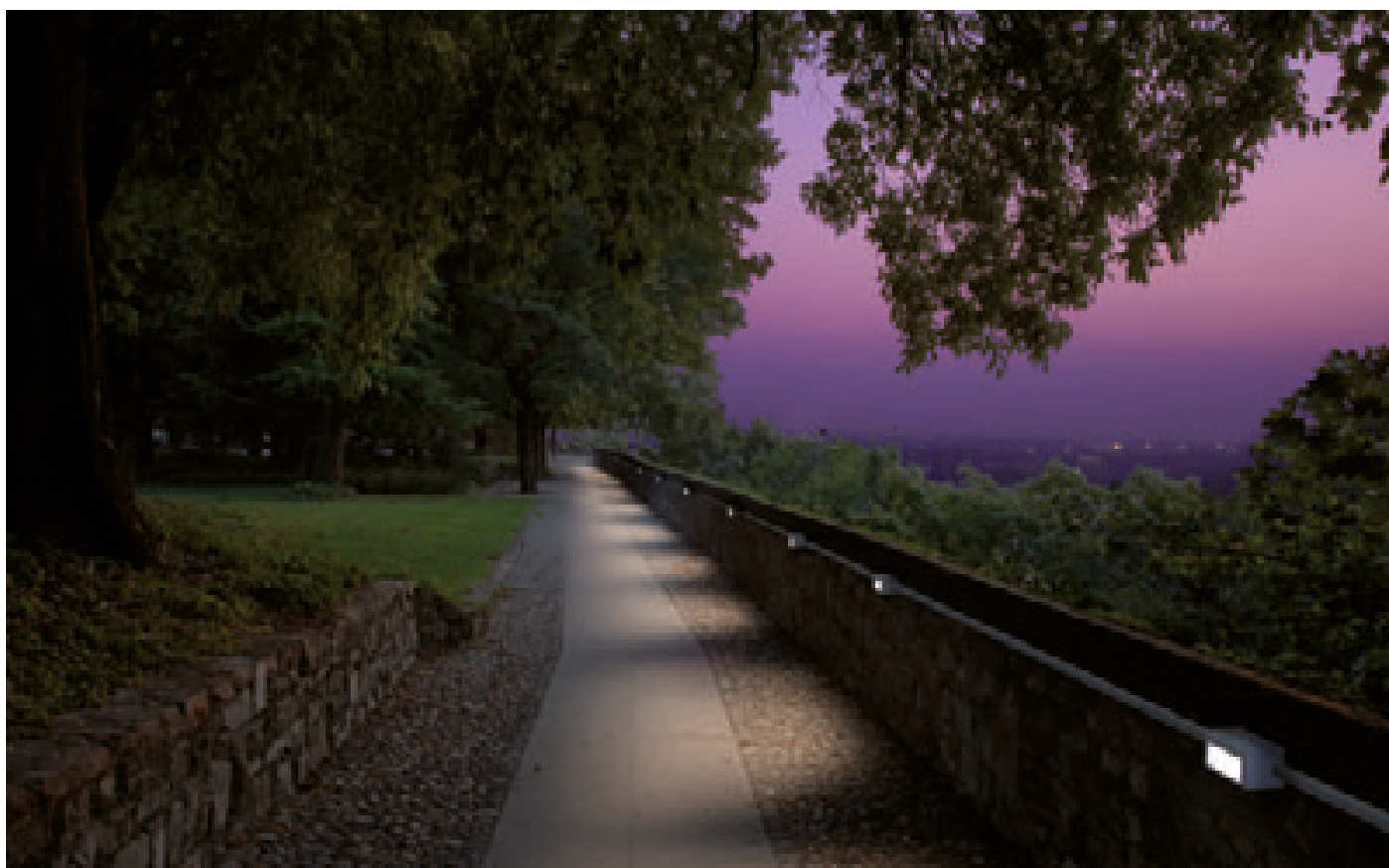

QUANTUM

CANALE PORTACAVI | CABLE TRUNKING

Code + Colour

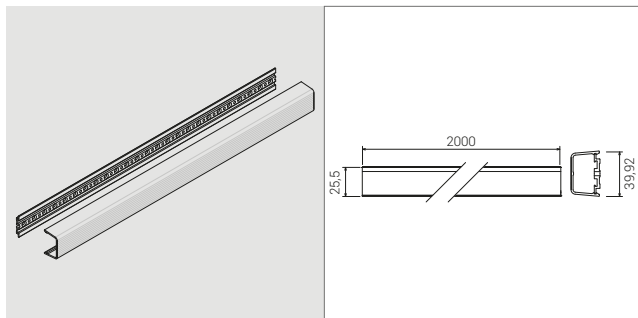

CODE DESCRIZIONE / DESCRIPTION

GR GM

5401* Canale completo / Bar + conduit

Barra reggi-canale in alluminio estruso.
Canale a vista in alluminio estruso verniciato.
Supporto e canale accorciabili a misura.
Completo di 10 supportini ferma cavo.
Innesto del canale sul supporto a scatto.
Resistenza meccanica IK10 (20 joule).
Verniciatura a polvere poliestere dopo fosfocromatazione stabilizzata raggi UV.

*Holding bar in extruded aluminium
Vandal proof aluminium conduit.
Bar + conduit suitable to be cut. 10 cable-holding clips inside.
Snapping connection bar/conduit.
IK10 (20 joules) impact test.
Pre-phosphochrome + UV resistant coating.*

CE

STAFFA DI GIUNZIONE | CONNECTION BRACKET

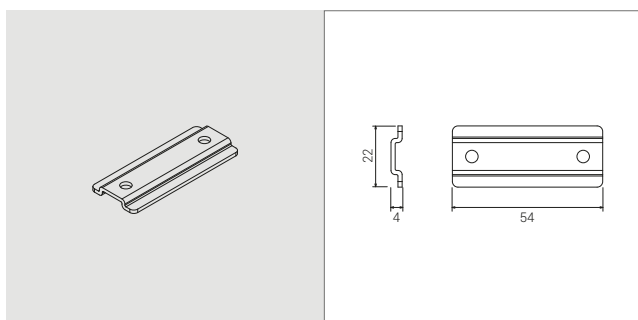

CODE DESCRIZIONE / DESCRIPTION

5402 Staffa di giunzione / Connection bracket

Staffa in acciaio per collimare due spezzoni di canale.
Struttura in acciaio grezzo.

*Steel bracket to connect two conduits.
Made in unpainted steel*

RACCORDI INGRESSO CAVI | CABLE ENTRY CONNECTION

Code + Colour

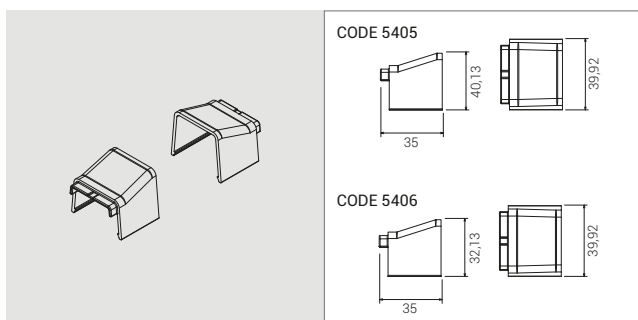

CODE DESCRIZIONE / DESCRIPTION

GR GM

5405* Coppia raccordi per / Connection pair for 5411-5412

5406* Coppia raccordi per / Connection pair for 5415-5416

Coppia di raccordi in alluminio.
Coprono il bocchettone di ingresso cavi nel contenitore.

*Pair of connections in aluminium.
To cover cable entry.*

TAPPO CHIUSURA | SIDE CAP

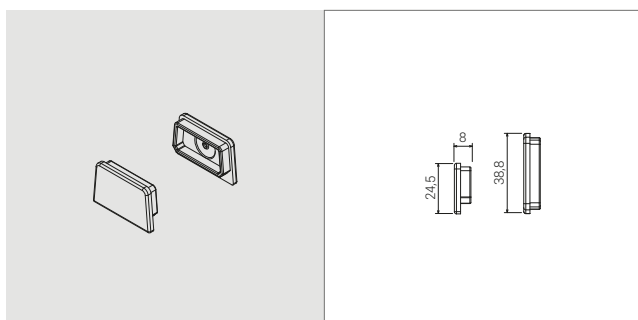

CODE DESCRIZIONE / DESCRIPTION

5407 Tappo chiusura / Side cap

Tappo chiusura canale in gomma grigia.

Rubber side cap.

QUANTUM

Paletti da giardino
Garden posts



PALO ALLUMINIO | ALUMINIUM POST

Code + Colour + Tonality

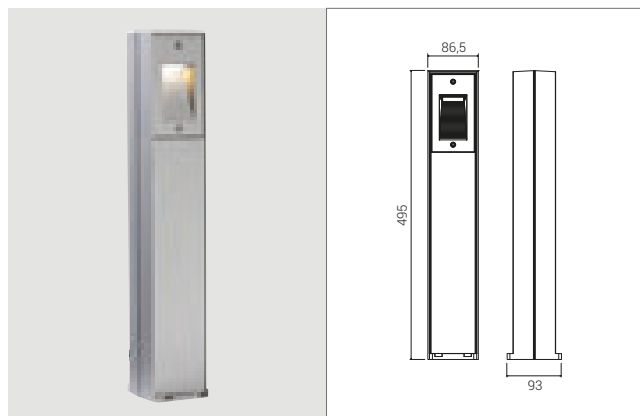

CODE	LAMP	W	lm	Nominali-Real output	GR	GM
5591*	Led	3,2	280	178		

Palo in alluminio completo di apparecchio Led frontale 3,2 W e maschera.

In opzione è possibile inserire corpo 5440 sul retro con maschere 5465 o 5466.

Cassetta di derivazione incorporata.

Doppia verniciatura a polvere poliestere

dopo fosfocromatazione stabilizzata

raggi UV. Colore Corten a richiesta.

IP 65 / Classe II / IK 10

CRI 85 / Driver IN / 350 mA

230V / 50 Hz

CE

Tonalità 3000K o 4000K. Aggiungere 3K o 4K al codice dopo il colore.

Post in aluminium complete with Led

body in front 3,2 W + mask 5462.

Option to insert on the back the body

5440 and the mask 5465 or 5466.

Connection box inside.

Pre-phosphochrome + UV resistant

coating. Corten colour available upon

request.

IP 65 / Class II / IK 10

CRI 85 / Driver IN / 350 mA

230V / 50 Hz

CE

Color temperature available 3000K or 4000K. Add 3K or 4K to the code after the color.

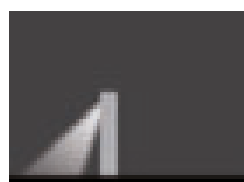
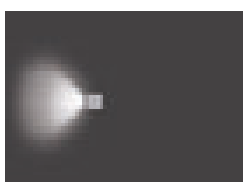

Palo Quantum
con una lampada.
Quantum post.
One light.

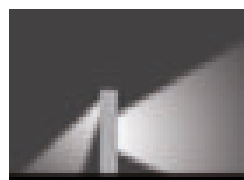

Palo Quantum
con due lampade.
Quantum post.
Two lights.

PIASTRA TIRAFONDI | PLATE WITH ANCHORING SET

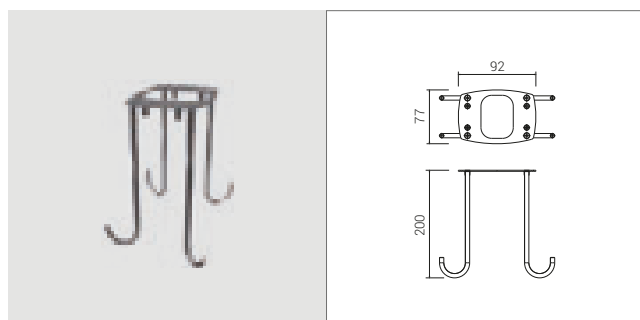

CODE	DESCRIZIONE / DESCRIPTION
5496	Piastra tirafondi / Plate with anchoring set

Piastra inox con tirafondi per ancoraggio al terreno.

Pronta a montare per art. 5591.

Stainless steel plate with ground anchoring set.

To be installed with codes 5591.



QUANTUM

Piantane da giardino
Garden posts



PIANTANA ALLUMINIO | ALUMINIUM POST

Code + Colour + Tonality

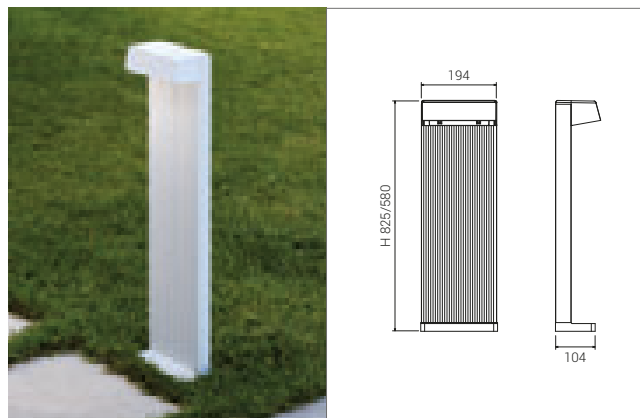

CODE	LAMP	H	W	Im	Nominali-Real output	GR	GM
5593*	Led	825 mm	13	1500	1100		
5594*	Led	580 mm	13	1500	1100		

Piantana in alluminio completa di apparecchio Led 13 W. Completa di piastra inox reggi-tirafondi. Cassetta di derivazione incorporata. Doppia verniciatura a polvere poliestere dopo fosfocromatazione stabilizzata raggi UV. Colore Corten a richiesta.
IP 65 / Classe II / IK 10
CRI 85 /Driver IN / 350 mA
230V / 50 Hz
CE
Tonalità 3000K o 4000K. Aggiungere 3K o 4K al codice dopo il colore.

Post in aluminium complete with Led 13 W. With stainless steel plate holding the anchoring set. Connection box inside. Pre-phosphochrome + UV resistant coating. Corten colour available upon request.
IP 65 / Class II / IK 10
CRI 85 /Driver IN / 350 mA
230V / 50 Hz
CE
Color temperature available 3000K or 4000K. Add 3K or 4K to the code after the color.



Code + Colour + Tonality

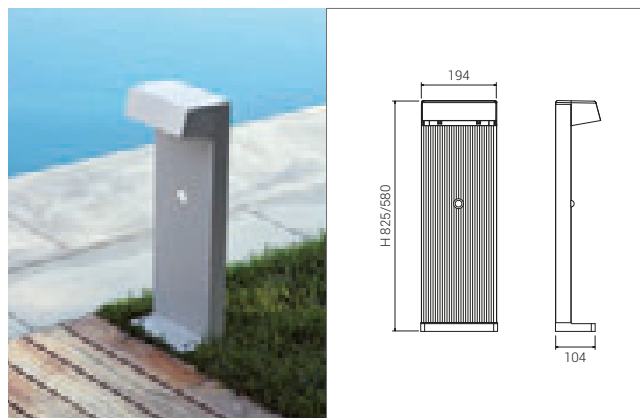

CODE	LAMP	H	W	Im	Nominali-Real output	GR	GM
5597*	Led	825 mm	13	1500	1100		
5599*	Led	580 mm	13	1500	1100		

Piantana in alluminio completa di apparecchio Led 13 W. Completa di rilevatore di presenza a raggi infrarossi; tre regolazioni. Completa di piastra inox reggi-tirafondi. Cassetta di derivazione incorporata. Doppia verniciatura a polvere poliestere dopo fosfocromatazione stabilizzata raggi UV. Colore Corten a richiesta.
IP 65 / Classe II / IK 10
CRI 85 /Driver IN / 350 mA
230V / 50 Hz
CE
Tonalità 3000K o 4000K. Aggiungere 3K o 4K al codice dopo il colore.

Post in aluminium complete with Led 13 W. With infrared sensor; three regulations. With stainless steel plate holding the anchoring set. Connection box inside. Pre-phosphochrome + UV resistant coating. Corten colour available upon request.
IP 65 / Class II / IK 10
CRI 85 /Driver IN / 350 mA
230V / 50 Hz
CE
Color temperature available 3000K or 4000K. Add 3K or 4K to the code after the color.

TIRAFONDI | ANCHORING SET

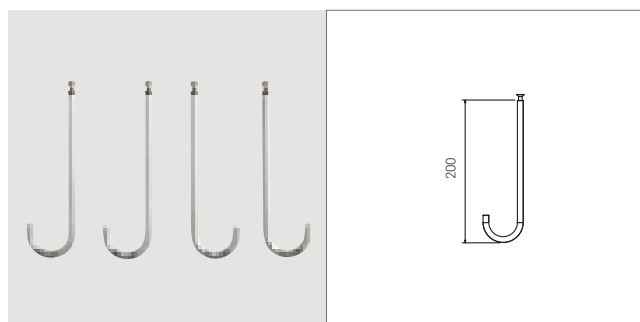

CODE	DESCRIZIONE / DESCRIPTION
5529	Tirafondi / Anchoring set

4 tirafondi per ancoraggio al terreno.

4 ground anchoring set.



QUANTUM

Pali bassi da giardino per installazione su muretto o a terra
Small garden posts for wall or ground installation



PALO BASSO | SMALL GARDEN POST

Code + Colour + Tonality

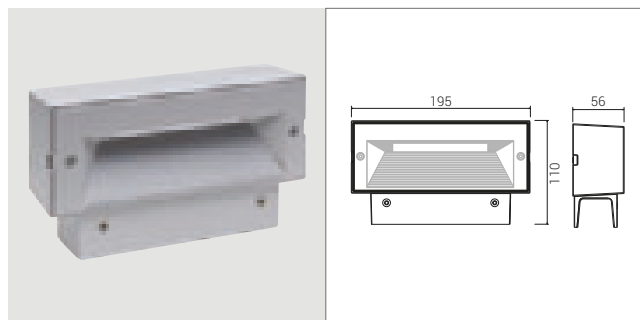

CODE	LAMP	W	lm	Nominali-Real output	GR	GM
5596*	Led	4,2	430	273		

Struttura interamente in alluminio.
 Completo di apparecchio Led 4,2 W e maschera.
 Predisposto per collegamento da sotto o laterale.
 Morsetteria entra/esci incorporati.
 Doppia verniciatura a polvere poliestere dopo fosfocromatazione stabilizzata raggi UV. Colore Corten a richiesta.
 IP 65 / Classe II / IK 10
 CRI 85 /Driver IN / 350 mA / 230V / 50 Hz
CE
Tonalità 3000K o 4000K.
Aggiungere 3K o 4K al codice dopo il colore.

*Structure totally in aluminium.
 Complete with Led 4,2 W + mask included.
 Side and bottom cable entry.
 Through wiring allowed.
 Pre-phosphochrome + UV resistant coating. Corten colour available upon request.
 IP 65 / Class II / IK 10
 CRI 85 /Driver IN / 350 mA / 230V / 50 Hz
CE
Color temperature available 3000K or 4000K.
Add 3K or 4K to the code after the color.*

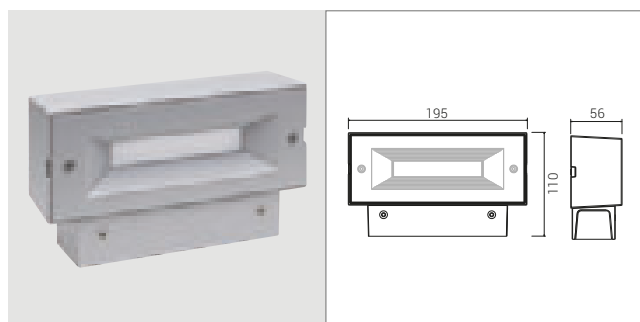
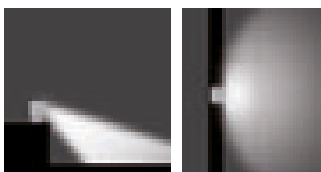

CODE	LAMP	W	lm	Nominali-Real output	GR	GM
5598*	Led	4,2	430	325		

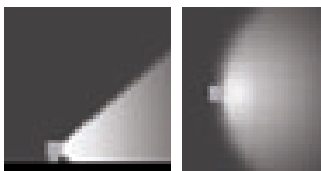





PASSUM

SERIE DA INCASSO A TERRA E A PARETE
GROUND AND WALL RECESSED LUMINAIRES FOR OUTDOORS

La Serie PASSUM di lampade da incasso è composta da una nuova generazione di apparecchi che risolvono al meglio le esigenze di illuminazione verso l'alto o radente sul terreno. Si distinguono per le soluzioni tecniche innovative, la componibilità e le particolarità costruttive, totalmente e orgogliosamente italiane, che consentono di garantire resistenza, bassa temperatura superficiale, perfetta tenuta stagna, resistenza alla corrosione, carrabilità, intercambiabilità delle coppe o degli anelli di finitura e versatilità di installazione. Le particolari soluzioni di basculaggio o di orientamento del corpo illuminante a LED o tradizionale, consentono di regolare l'inclinazione della luce per una perfetta illuminazione delle superfici.

PASSUM is a new range of recessed lighting fittings planned to contain new generation power leds. The right match for contemporary architecture when up light and ground surface light is required. Hi-tech materials and innovative construction concepts, proudly Italian, allow to offer a product with complete modularity, low surface temperature, perfect waterproof security, walk over and driver over function and resistance to any harsh weather conditions. The peculiar technology to adjust the optics of the light body grants to orient the light wherever the Designer will need, for the right illumination of the surfaces.







PASSUM UP

Incasso a terra o parete, luce verso l'alto, basculabili
*Ground and wall recessed up-light luminaires,
 adjustable optic*



PASSUM SIDEWARDS

Incasso a terra o parete, luce radente
Ground and wall recessed, ground surface light.



PASSUM UP ultraflat

Incasso a terra o parete, basso spessore
Low depth recessed up-light



PASSUM orientabile/adjustable

Incasso a terra o parete, luce orientabile
Ground recessed, adjustable optic





PASSUM UP

Incasso a terra o parete, luce verso l'alto, basculanti
Ground + wall recessed up-lights, adjustable optic walk over + driver over

CARATTERISTICHE GENERALI

- Serie da incasso a terra/parete.
- **Struttura:** corpo lampada in alluminio primario a basso contenuto di rame, verniciato con polveri poliestere anticorrosione dopo fosfocromatazione, oppure in acciaio INOX AISI 316L. Disponibile in 4 diametri: \varnothing 70, 125, 180 e 245 mm.
- Vetro temperato trasparente con $T \leq 40^\circ\text{C}$; spessore da 6 a 12 mm e carico massimo da 2.000 a 3.500 Kg. Su richiesta anche opale e antiscivolo.
- Corpo lampada fornito con vetro e 0,5 m di cavo interrabile H07RN-F con giunto di connessione IP68 solo con flangia intercambiabile.
- Controcasse a ridotto spessore in tecnopolimero stabilizzato.
- La versione \varnothing 125 ultraflat con vetro opale si interfaccia con cassaforma h=115 mm totale.
- Le flange di chiusura sono fornite a parte: tonde in alluminio primario a doppia verniciatura; tonde e quadre in INOX AISI 316L con viti inox a brugola.
- **Sorgenti luminose** a basso consumo e a Led da 1, 3, 4, 8, 9,5 e 29 W con CRI 80 e vita garantita 60.000 h con decremento max del 20% - L80B20.
- Driver remoto per \varnothing 70, incorporato per \varnothing 125, 180 e 245.
- Ottica fissa per \varnothing 70, basculante $\pm 15^\circ$ per \varnothing 125 e 180 e $\pm 25^\circ$ per \varnothing 245
- Costruito in conformità alle norme europee EN 60598-1:2015 **CE**

MASSIMA COMPONIBILITÀ

Le lampade della serie sono fornite in 3 elementi separati:

- 1 - controcassa a interrare
- 2 - corpo lampada in alluminio o INOX AISI 316L
- 3 - flange di chiusura intercambiabili in alluminio o INOX AISI 316L

MAXIMUM MODULARITY

The lighting fittings of the range are supplied in 3 separate parts:

- 1 - Recessing box
- 2 - Light body in aluminium or AISI 316L stainless steel
- 3 - Changeable flanges in aluminium or AISI 316L stainless steel

OTTICA BASCULANTE E ROTANTE

L'ottica delle lampade è basculabile per $\pm 15^\circ/25^\circ$ (escluso $\varnothing 70$) e ruota sul piano orizzontale per un corretto posizionamento del fascio luminoso.

ADJUSTABLE AND ROUTABLE OPTIC

Fully adjustable optic (unless for \varnothing 70 mm). Vertically $\pm 15^\circ$ for \varnothing 125 and 180 mm and $\pm 25^\circ$ for \varnothing 245 mm. Horizontally for the right firing.

MESSA A BOLLA DEL CORPO LAMPADA

Dopo l'installazione nella cassaforma, è possibile regolare la messa a bolla del corpo lampada.

LIGHT BODY HORIZONTAL REGULATION

After inserting the light body in the recessed box is possible a complete planning regulation, to level out the fitting.

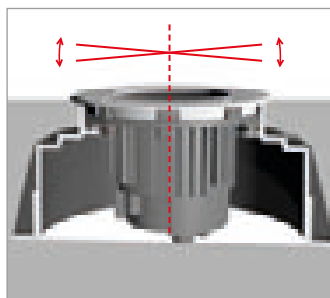
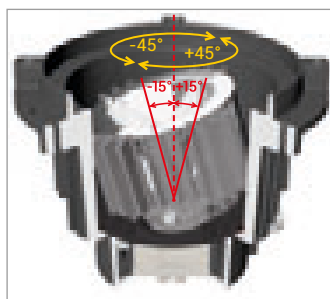

GENERAL FEATURES

- In-ground and wall recessed range.
- **Housing:** lighting body in primary low copper content aluminum alloy, painted in double coat polyester powders after phosphochrome, or in AISI 316L stainless steel. Resistant to UV rays and harsh weather conditions. Available in \varnothing 70/125/180 and 245 mm.
- Security tempered glass with touch temperature $T \leq 40^\circ\text{C}$. Thickness from 6 to 12 mm. Load up pressure max 2.000 Kg - 3.500 Kg (1.000 Kg for 70 mm). Opal glass and skidproof glass on request.
- Any fitting of the range is pre-wired with 0,5 mt H07RN-F cable and connection block IP68.
- Low depth recessing box in waterproof technopolymer.
- The ultra-flat version \varnothing 125 mm is suitable to be inserted in a backbox 115 mm depth only.
- The covering flanges are supplied separately, available in copper free aluminium or in stainless steel AISI 316 L with stainless steel screws.
- **Lighting sources:** power led 1/3/4/8/9,5 and 29W with CRI 80 minimum. Life 60.000 hours with max decreasing of 20% (L80B20).
- Remote control driver for \varnothing 70 mm and driver inside for \varnothing 125/180/245 mm.
- Fixed optic for \varnothing 70 m, fully adjustable $\pm 15^\circ$ for \varnothing 125 and 180 mm and $\pm 25^\circ$ for \varnothing 245 mm.
- Manufactured in compliance with European standards EN 60598-1:2015 **CE**

CAVO E GIUNTO INTERRABILI

Tutti i corpi lampada sono precablati con 0,5 m di cavo interrabile H07RN-F e giunto di connessione IP68.

IN-GROUND WIRING

Any fitting of the range is pre-wired with 0,5 mt H07RN-F cable and connetion block IP 68.



CALPESTABILI E CARRABILI

Max $T \leq 40^\circ\text{C}$. Carico massimo da 2.000 a 3.500 Kg (1000 Kg per \varnothing 70 mm) indicato per aree carrabili e calpestabili.

WALK OVER AND DRIVE OVER

Max surface $T \leq 40^\circ\text{C}$ and load up pressure max 2.000-3.500 Kg (1000 Kg for \varnothing 70 mm).

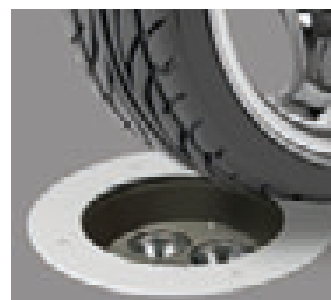

FLANGE INTERCAMBIABILI

Sono disponibili in 3 versioni (INOX e alluminio) per ciascun diametro.

MODULAR COVERING FLANGES

Available in three versions: aluminium and AISI 316L stainless steel.



PASSUM UP $\phi 70$

Incasso a terra o parete
Ground + wall recessed



CASSAFORMA | IN-GROUND BOX

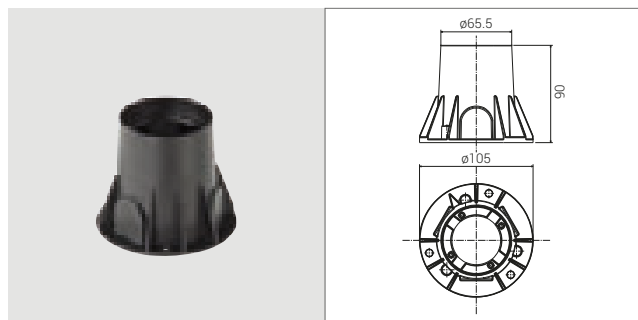

CODE DESCRIZIONE / DESCRIPTION

1411 Cassaforma / In-ground box $\phi 70$ mm

Cassaforma in tecnopolimero stabilizzato a interrare o da parete.

In-ground box in waterproof technopolymer.

CORPO LAMPADA | LIGHT BODY $\phi 70$ mm

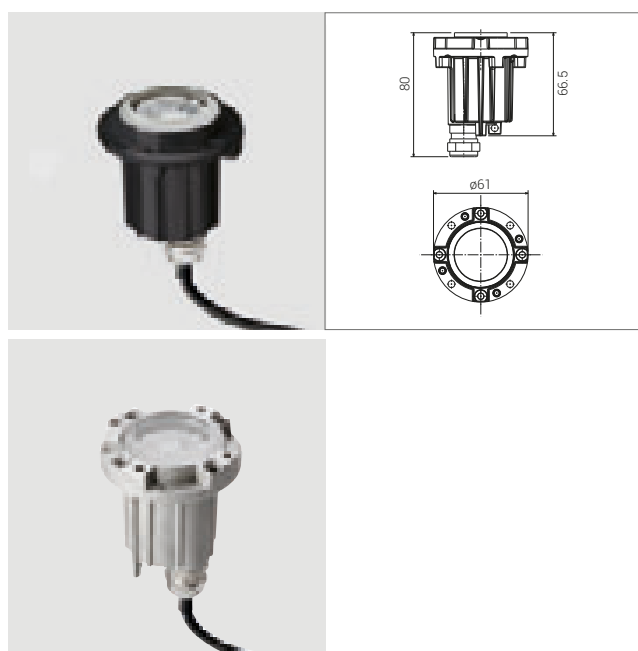

Alluminio - Aluminium

Code + Tonality

CODE	LAMP	W	Im	Nominali-Real output
1412	○ Led	1/24V DC	105	60
1413	○ Led	3/24V DC	185	101

Ottica fissa. Driver OUT.

24V DC per collegamento in parallelo.

Vetro trasparente 6 mm.

Carico max. 1000 Kg.

IP 67 con flange / Classe III \diamond / IK 08

CRI 80 / Driver OUT

CE

Tonalità 3000K o 4000K.

Aggiungere 3K o 4K dopo il codice.

Fixed optic. Driver OUT.

24V DC for parallel connection.

Clear glass 6 mm.

Max load pressure 1000 Kg.

IP 67 with flanges / Class III \diamond / IK 08

CRI 80 / Driver OUT

CE

Color temperature available 3000K or 4000K. Add 3K or 4K to the code.

INOX AISI 316L - AISI 316L stainless steel

Code + Tonality

CODE	LAMP	W	Im	Nominali-Real output
1491	○ Led	1/24V DC	105	60
1494	○ Led	3/24V DC	185	101

Stesse caratteristiche degli art. 1412-1413.

Same features as codes 1412-1413.

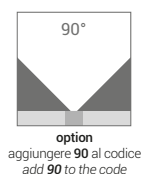
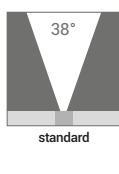
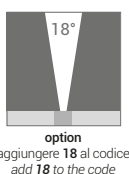

FLANGE INTERCAMBIABILI | CHANGEABLE FLANGES 70 mm

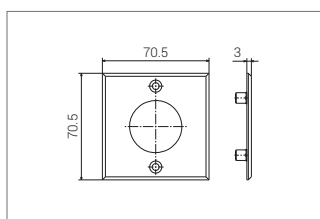
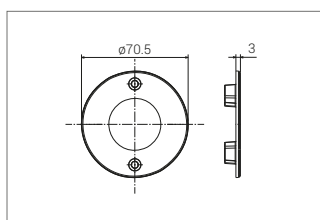

Alluminio - Aluminium

Code + Colour

CODE DESCRIZIONE / DESCRIPTION

GM

1511* Tonda / Round $\phi 70$

INOX AISI 316L - AISI 316L stainless steel

Code + Colour

CODE DESCRIZIONE / DESCRIPTION

IN

1512* Tonda / Round $\phi 70$

1513* Quadrata / Square 70 x 70

A richiesta l'insieme corpo lampada+flangia viene fornito montato, sigillato e orientato.
The set light body+flange can be supplied assembled, sealed and oriented.

Curve fotometriche: vedi capitolo specifico. Classe Energetica: vedi capitolo specifico.
Photometric data: go to relevant chapter. Energy class: go to code index.

PASSUM UP $\phi 125$

Incasso a terra o parete
Ground + wall recessed



CASSAFORMA | IN-GROUND BOX

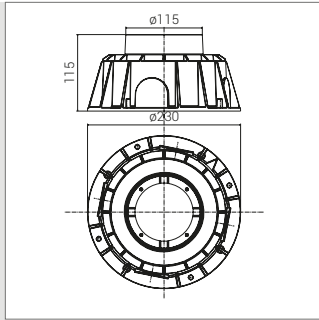

CODE DESCRIZIONE / DESCRIPTION

1421 Cassaforma / In-ground box $\phi 125$ mm

Cassaforma in tecnopolimero stabilizzato a interrare o da parete.

In-ground box in waterproof technopolymer.

CORPO LAMPADA | LIGHT BODY $\phi 125$ mm

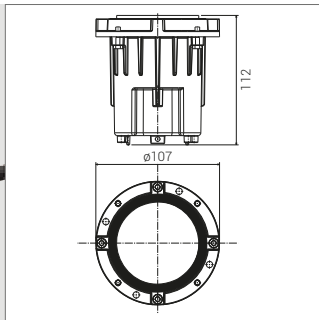

Alluminio - Aluminium

Code + Tonality

CODE LAMP W lm Nominali-Real output

1422 Led 4/230V 410 256

1424 GU 10 L max 57mm 5

Ottica basculante $\pm 15^\circ$ per cod.1422-1495, $\pm 8^\circ$ per cod.1424-1496.

Vetro trasparente 10 mm.

Carico max. 2000 Kg.

Cod.1424-1496 forniti senza lampadina.

IP 67 con flange / Classe I / IK 10

CRI 80 / Driver IN / 350 mA

230V / 50 Hz / 24V DC a richiesta €

Tonalità 3000K o 4000K.

Aggiungere 3K o 4K dopo il codice.

Fully adjustable optic $\pm 15^\circ$ for code 1422-1495, $\pm 8^\circ$ for code 1424-1496.

Clear glass 10 mm.

Max load pressure 2000 Kg.

Code 1424-1496 supplied without lamp.

IP 67 with flanges / Class I / IK 10

CRI 80 / Driver IN / 350 mA

230V / 50 Hz / 24V DC on request €

Color temperature available 3000K or 4000K. Add 3K or 4K to the code.

INOX AISI 316L - AISI 316L stainless steel

Code + Tonality

CODE LAMP W lm Nominali-Real output

NEW 1495 Led 4/230V 410 256

NEW 1496 GU 10 L max 57mm 5

Stesse caratteristiche degli art. 1422-1424.

Same features as codes 1422-1424.

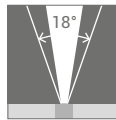

option
aggiungere 18 al codice
add 18 to the code

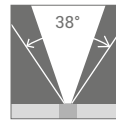

standard

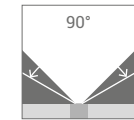

option
aggiungere 90 al codice
add 90 to the code

FLANGE INTERCAMBIABILI | CHANGEABLE FLANGES 125 mm



1521



1522

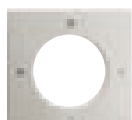

1523

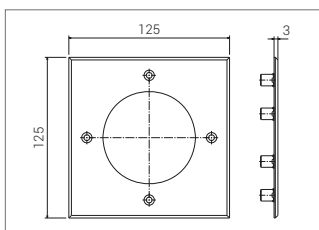
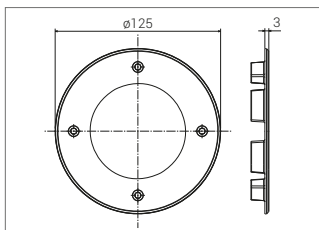

Alluminio - Aluminium

Code + Colour

CODE DESCRIZIONE / DESCRIPTION

1521* Tonda / Round $\phi 125$

INOX AISI 316L - AISI 316L stainless steel

Code + Colour

CODE DESCRIZIONE / DESCRIPTION

1522* Tonda / Round $\phi 125$

1523* Quadrata / Square 125 x 125

A richiesta l'insieme corpo lampada+flangia viene fornito montato, sigillato e orientato.
The set light body+flange can be supplied assembled, sealed and oriented.

Curve fotometriche: vedi capitolo specifico. Classe Energetica: vedi capitolo specifico.
Photometric data: go to relevant chapter. Energy class: go to code index.

PASSUM UP $\varnothing 125$ ultraflat

Incasso a terra o parete basso spessore
Ground + wall recessed - low depth



CASSAFORMA ULTRAFLAT | ULTRAFLAT IN-GROUND BOX

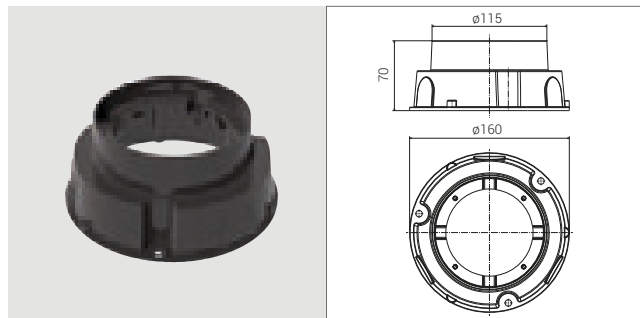

CODE DESCRIZIONE / DESCRIPTION

1423 Cassaforma Ultraflat / Ultraflat in-ground box $\varnothing 125$ mm

Cassaforma con profondità di incasso molto contenuta. In tecnopolimero stabilizzato.
A interrare o da parete.

Ultraflat in-ground box in waterproof technopolymer.

CORPO LAMPADA ULTRAFLAT | ULTRAFLAT LIGHT BODY $\varnothing 125$ mm

Code + Tonality

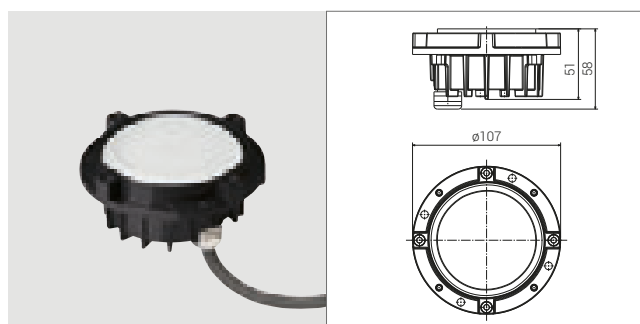

CODE LAMP W Im Nominali-Real output

1401 \bigcirc Led 8/230V 800 355

Ottica fissa.

Vetro opale 10 mm, carico max 2000 Kg.
IP 67 con flange / Classe I / IK 10
CRI 80 / Driver IN / 350 mA
230V / 50 Hz

CE

Tonalità 3000K o 4000K.

Aggiungere 3K o 4K dopo il codice.

Fixed optic.

Opal glass 10 mm. Max load pressure 2000 Kg.
IP 67 with flanges / Class I / IK 10
CRI 80 / Driver IN / 350 mA
230V / 50 Hz

CE

Color temperature available 3000K or 4000K. Add 3K or 4K to the code.

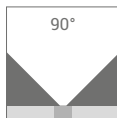

FLANGE INTERCAMBIABILI | CHANGEABLE FLANGES 125 mm

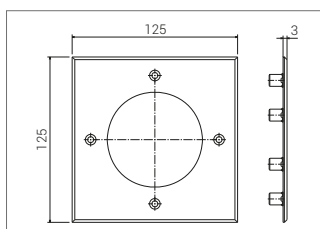
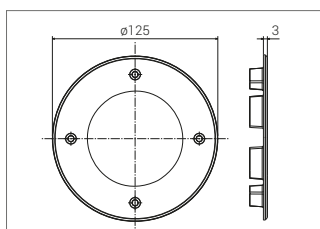

Alluminio - Aluminium

Code + Colour

CODE DESCRIZIONE / DESCRIPTION

GM

1521* Tonda / Round $\varnothing 125$

INOX AISI 316L - AISI 316L stainless steel

Code + Colour

CODE DESCRIZIONE / DESCRIPTION

IN

1522* Tonda / Round $\varnothing 125$

1523* Quadrata / Square 125 x 125

A richiesta l'insieme corpo lampada+flangia viene fornito montato, sigillato e orientato.
The set light body+flange can be supplied assembled, sealed and oriented.

Curve fotometriche: vedi capitolo specifico. Classe Energetica: vedi capitolo specifico.
Photometric data: go to relevant chapter. Energy class: go to code index.

PASSUM UP $\varnothing 180$

Incasso a terra o parete
Ground + wall recessed

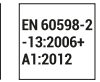

CASSAFORMA | IN-GROUND BOX

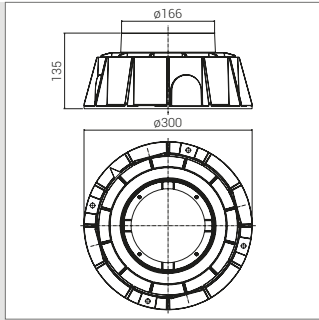

CODE DESCRIZIONE / DESCRIPTION

1431 Cassaforma / In-ground box $\varnothing 180$ mm

Cassaforma in tecnopolimero stabilizzato a interrare o da parete.

In-ground box in waterproof technopolymer.

CORPO LAMPADA | LIGHT BODY $\varnothing 180$ mm

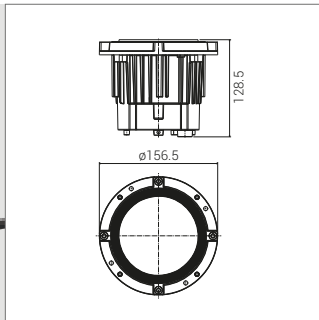

Alluminio - Aluminium

Code + Tonality

CODE LAMP W lm Nominali-Real output

1432 Led 9,5/230V 1200 806

1434 GU 10 L max 86mm 7-8

Optica basculante $\pm 15^\circ$.

Vetro trasparente 12 mm.

Carico max. 3500 Kg

Versione antiscivolo a richiesta.

Cod.1434-1498 forniti senza lampadina.

IP 67 con flange / Classe I / IK 10

CRI 80 / Driver IN / 350 mA

230V / 50 Hz / 24V DC a richiesta €

Tonalità 3000K o 4000K.

Aggiungere 3K o 4K dopo il codice.

Fully adjustable optic $\pm 15^\circ$.

Clear glass 12 mm.

Max load pressure 3500 Kg.

Skidproof glass on request.

Code 1434-1498 supplied without lamp.

IP 67 with flanges / Class I / IK 10

CRI 80 / Driver IN / 350 mA

230V / 50 Hz / 24V DC on request €

Color temperature available 3000K or 4000K. Add 3K or 4K to the code.

INOX AISI 316L - AISI 316L stainless steel

Code + Tonality

CODE LAMP W lm Nominali-Real output

NEW **1497** Led 9,5/230V 1200 806

NEW **1498** GU 10 L max 86mm 7-8

Stesse caratteristiche degli art. 1432-1434

Same features as codes 1432-1434.

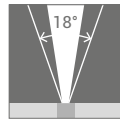

option
aggiungere 18 al codice
add 18 to the code

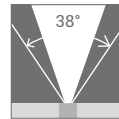

standard

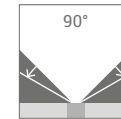

option
aggiungere 90 al codice
add 90 to the code

FLANGE INTERCAMBIABILI | CHANGEABLE FLANGES 180 mm

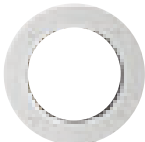

1531



1532



1533

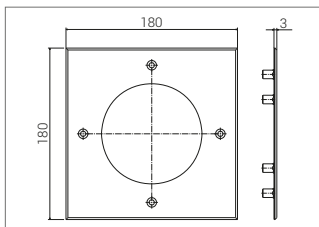
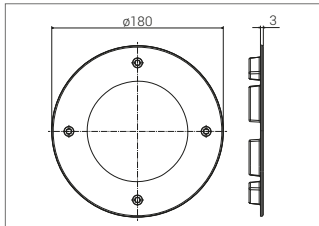

Alluminio - Aluminium

Code + Colour

CODE DESCRIZIONE / DESCRIPTION

GM

1531* Tonda / Round $\varnothing 180$

INOX AISI 316L - AISI 316L stainless steel

Code + Colour

CODE DESCRIZIONE / DESCRIPTION

IN

1532* Tonda / Round $\varnothing 180$

1533* Quadrata / Square 180 x 180

A richiesta l'insieme corpo lampada+flangia viene fornito montato, sigillato e orientato.
The set light body+flange can be supplied assembled, sealed and oriented.

Curve fotometriche: vedi capitolo specifico. Classe Energetica: vedi capitolo specifico.
Photometric data: go to relevant chapter. Energy class: go to code index.





PASSUM UP $\varnothing 245$

Incasso a terra
Ground recessed



CASSAFORMA | IN-GROUND BOX

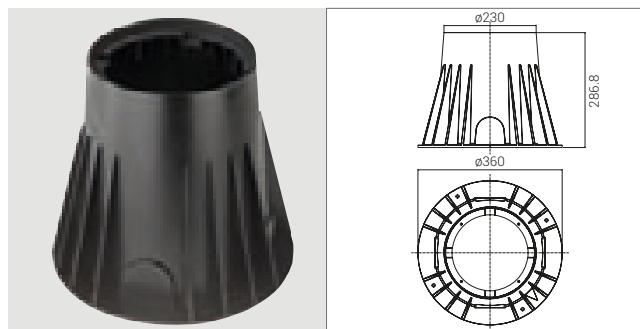

CODE DESCRIZIONE / DESCRIPTION

1441 Cassaforma / In-ground box $\varnothing 245$ mm

Cassaforma in tecnopolimero stabilizzato a interrare. *In-ground box in waterproof technopolymer.*

CORPO LAMPADA | LIGHT BODY $\varnothing 245$ mm

Code + Tonality

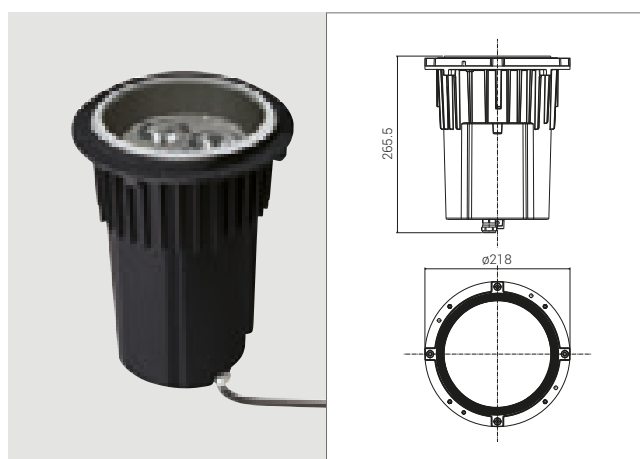

CODE LAMP W Im Nominali-Real output

1442 Led 29/230V 3600 2294

1443 Ioduri Metallici Metal Halide 70/230V

1444 E27 L max 195 30/230V

Ottica basculante $\pm 25^\circ$.
Vetro trasparente 12 mm.
Carico max. 3500 Kg
Versione antiscivolo a richiesta.
Cod.1443/1444 forniti senza lampadina.
IP 67 con flange / Classe I / IK 10
CRI 80 / Driver IN / 350 mA
230V / 50 Hz **CE**
Tonalità 3000K o 4000K.
Aggiungere 3K o 4K dopo il codice.

Adjustable optic $\pm 25^\circ$.
Clear glass 12 mm.
Max load pressure 3500 Kg.
Skidproof glass on request.
Code 1443/1444 supplied without lamp.
IP 67 with flanges / Class I / IK 10
CRI 80 / Driver IN / 350 mA
230V / 50 Hz **CE**
Color temperature available 3000K or 4000K. Add 3K or 4K to the code.

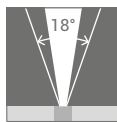

1442 - 1443
option
aggiungere **18** al codice
add **18** to the code

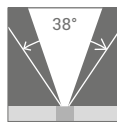

1442 - 1443
standard

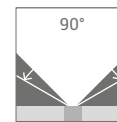

1442
option
aggiungere **90** al codice
add **90** to the code

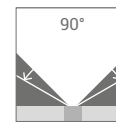

1444
standard

FLANGE INTERCAMBIABILI | CHANGEABLE FLANGES 245 mm

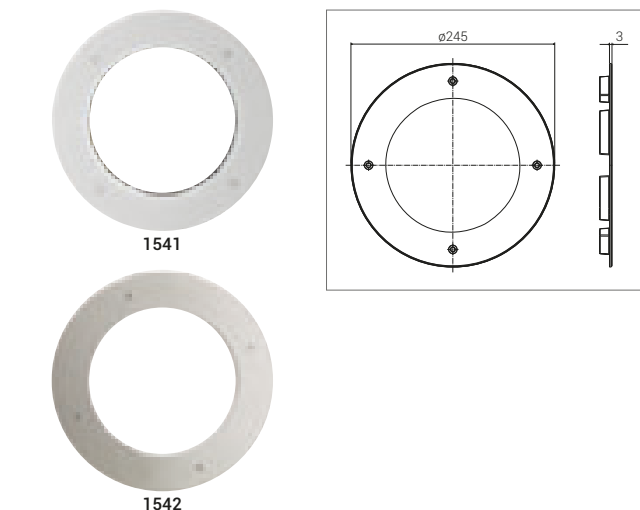

Alluminio - Aluminium

Code + Colour

CODE DESCRIZIONE / DESCRIPTION

GM

1541* Tonda / Round $\varnothing 245$

INOX AISI 316L - AISI 316L stainless steel

Code + Colour

CODE DESCRIZIONE / DESCRIPTION

IN

1542* Tonda / Round $\varnothing 245$

A richiesta l'insieme corpo lampada+flangia viene fornito montato, sigillato e orientato.
The set light body+flange can be supplied assembled, sealed and oriented.

Curve fotometriche: vedi capitolo specifico. Classe Energetica: vedi capitolo specifico.
Photometric data: go to relevant chapter. Energy class: go to code index.

PASSUM UP $\varnothing 245$ RGBW



Incasso a terra, colore luce regolabile
Ground recessed, RGB + white adjustable + Dim

CASSAFORMA | IN-GROUND BOX

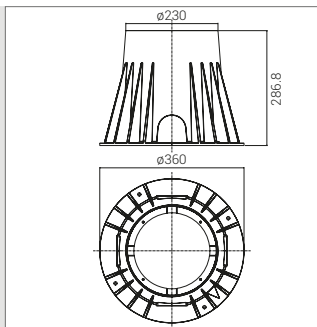

CODE DESCRIZIONE / DESCRIPTION

1441 Cassaforma / In-ground box $\varnothing 245$ mm

Cassaforma in tecnopolimero stabilizzato a interrare.

In-ground box in waterproof technopolymer.

CORPO LAMPADA RGB W | LIGHT BODY RGB W $\varnothing 245$ mm

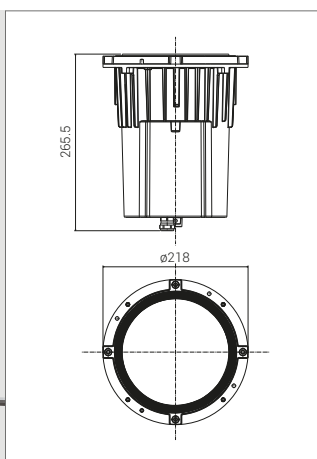

CODE LAMP W Im Nominali-Real output

1482  Led RGBW 20 525 244

Ottica basculante $\pm 25^\circ$.
Vetro trasparente 12 mm.
Carico max. 3500 Kg
Versione antiscivolo a richiesta.
IP 67 con flange / Classe I / IK 10
CRI 80 / Driver IN / 350 mA / RGBW
230V / 50 Hz
CE

Adjustable optic $\pm 25^\circ$.
Clear glass 12 mm.
Max load pressure 3500 Kg.
Skidproof glass on request.
IP 67 with flanges / Class I / IK 10
CRI 80 / Driver IN / 350 mA / RGBW
230V / 50 Hz
CE

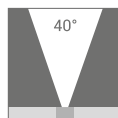

FLANGE INTERCAMBIABILI | CHANGEABLE FLANGES 245 mm

Vedi pagina 66.
See page 66.

GENERATORE DI SEGNALE | DMX SIGNAL GENERATOR

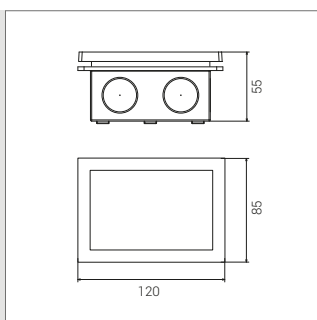

CODE DESCRIZIONE / DESCRIPTION

1180 DMX signal generator

Generatore monocanale di segnale DMX 512 Standard con comandi touch screen per pilotare il sistema RGBW (+ bianco). Gli apparecchi collegati alla centralina emettono tutti lo stesso colore. Funzioni: scelta colore / dimmerazione touch screen / rotazione colori / 4° colore bianco / regolazione della tonalità di luce da 2700K a 6000K. Led di segnalazione che identifica il comando. Emissione segnale fino alla distanza max di 300 m per un max di n° 32 apparecchi cod. 1482 collegati con appropriato cavo per DMX. Per distanze superiori amplificare il segnale con ripetitore di segnale DMX Standard 512. Alimentazione 230V; contiene trasformatore 230V/24V. Completo di scatola per incasso a muro.

Touch screen uni-channel DMX 512 standard signal generator, capable to drive the fittings to the system RGBW (+white).
The fittings connected will emit all together the same color.
Functions: color choice / color rotation / pure white fourth color / Dim the light / white tonality regulation from 2700K to 6000K.
A signal led shows color and function of the system.
Max. of 32 fittings code 1482 until 300m with the appropriate DMX cable.
For longer distances or signal missing use a relevant signal amplifier.
230V power, transformer 230V/24V inside
Complete with its backbox to recess in the wall.

A richiesta l'insieme corpo lampada+flangia viene fornito montato, sigillato e orientato.
The set light body+flange can be supplied assembled, sealed and oriented.

Curve fotometriche: vedi capitolo specifico. Classe Energetica: vedi capitolo specifico.
Photometric data: go to relevant chapter. Energy class: go to code index.



PASSUM SIDEWARDS

Lampade da incasso a terra o parete, luce radente
Ground + wall recessed, sideways emitting

CARATTERISTICHE GENERALI

- Serie da incasso a terra/parete.
- **Struttura:** corpo lampada in alluminio primario a basso contenuto di rame, verniciato con polveri poliestere anticorrosione dopo fosfocromatazione, oppure in acciaio INOX AISI 316L. Disponibili in 3 diametri: \varnothing 70, 125 e 180 mm.
- Corpo lampada fornito con coppa e 0,5 m di cavo interrabile H07RN-F con giunto di connessione IP68.
- Coppe in policarbonato anti UV con $T \leq 40^\circ \text{C}$ su tutti i modelli.
- Controcasse a ridotto spessore in tecnopolimero stabilizzato.
- **Calotte di chiusura**, in alluminio primario a doppia verniciatura, sono fornite a parte con 4 diverse possibilità di illuminazione radente: singola, doppia a 180° e 90° , a 360° .
- Carico massimo su tutti i modelli 2.000 kg.
- **Sorgente luminosa:** Led da 1, 3, 4 e 9,5 W con CRI 80. Vita: 60.000 h con decremento max del 20% - L80 B20.
- Driver remoto per \varnothing 70, incorporato per \varnothing 125 e 180.
- Ottica side emitter per indirizzare verso luce radente.
- La versione da \varnothing 180 mm con luce orientabile da 0° a 45° si trasforma in un poco invasivo proiettore per luce di accento.
- Costruito in conformità alle norme europee EN 60598-1:2015 CE

MASSIMA COMPONIBILITÀ

Le lampade della serie sono fornite in 3 elementi separati:

- 1 - controcassa a interrare,
- 2 - corpo lampada in alluminio o INOX AISI 316L
- 3 - calotte di chiusura intercambiabili in alluminio o INOX AISI 316L

MAXIMUM MODULARITY

The lighting fittings of the range are supplied in 3 separate parts:

- 1 - Recessing box
- 2 - Light body in aluminium or AISI 316L stainless steel
- 3 - Ground/wall drive over canopy in aluminium or AISI 316L stainless steel



OTTICA SIDE EMITTER

Led con ottica side emitter progettata per deviare tutta la luce radente sui lati.

SIDE EMITTER OPTIC

The lens turns the light and orient the along the ground surface.

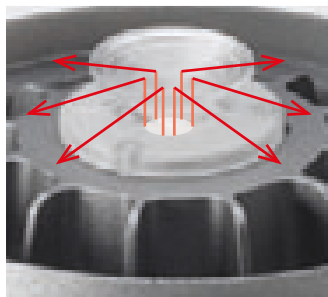

MESSA A BOLLA DEL CORPO LAMPADA

Dopo l'installazione nella cassaforma, è possibile regolare la messa a bolla del corpo lampada.

LIGHT BODY HORIZONTAL REGULATION

After inserting the light body in the recessed box is possible a complete planning regulation, to level out the fitting.

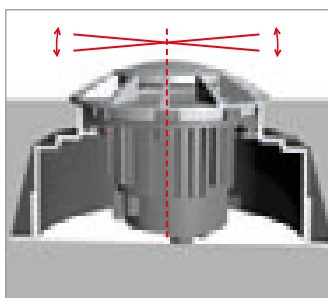

GENERAL FEATURES

- *In-ground and wall recessed range.*
- **Housing:** lighting body in primary low copper content aluminum alloy, painted in double coat polyester powders after phosphochrome, or in AISI 316L stainless steel. Resistant to UV rays and harsh weather conditions. Available in \varnothing 70/125 and 180 mm.
- Any fitting of the range is pre-wired with 0,5 mt H07RN-F cable and connection block IP68.
- Polycarbonate diffusers UV resistant with touch temperature $T \leq 40^\circ \text{C}$ for any model.
- Low depth recessing box in waterproof technopolymer.
- The **Covering canopies** are supplied separately in copper free aluminium with double layer of powder painting, resistant to any bad weather conditions, stainless steel screws. Available in four different emissions: 90° / $2 \times 90^\circ$ / 180° and 360° .
- Load up pressure max 2.000 for any model.
- **Lighting sources:** power led 1/3/4 and 9,5W with CRI 80 minimum. Life 60.000 hours with max decreasing of 20% (L80B20).
- Remote control driver for \varnothing 70 mm and driver inside for \varnothing 125 and 180 mm.
- Side emitter optic to turn the light along the ground surface.
- The version \varnothing 180 mm with fully adjustable optic from 0° to 45° towards up becomes a minimally invasive accent light.
- Manufactured in compliance with European standards EN 60598-1:2015 CE

CALPESTABILI E CARRABILI

Max $T \leq 40^\circ \text{C}$. Carico massimo 2.000 Kg indicato per aree carrabili e calpestabili.

WALK OVER AND DRIVE OVER

Max surface $T \leq 40^\circ \text{C}$ and load pressure max 2.000Kg.



CALOTTE INTERCambiabili ALLUMINIO

Sono fornite a parte con 4 diverse possibilità di orientare la luce radente.

CHANGEABLE CANOPIES IN ALUMINIUM

The covering canopies allows to orient the light in 4 different light emissions.

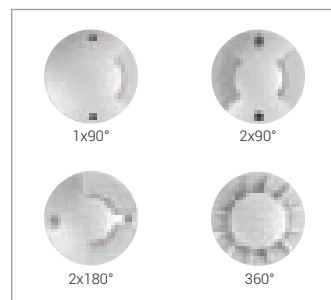

CALOTTE INOX AISI 316L

AISI 316L STAINLESS STEEL CANOPIES

NEW

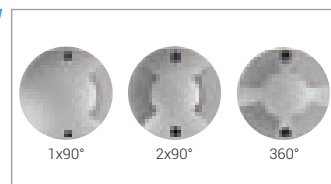

CAVO E GIUNTO INTERRABILI

Tutti i corpi lampada sono precablati con 0,5 m di cavo interrabile H07RN-F e giunto di connessione IP68.

IN-GROUND WIRING

Any fitting of the range is pre-wired with 0,5 mt H07RN-F cable and IP 68 connection block IP 68.

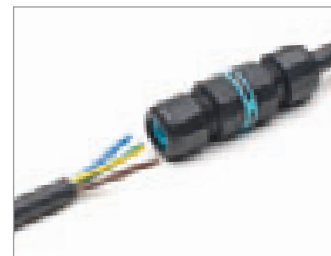

PASSUM $\phi 70$

Sideways

Incasso a terra o parete, luce radente
Ground + wall recessed for surface light



CASSAFORMA | IN-GROUND BOX

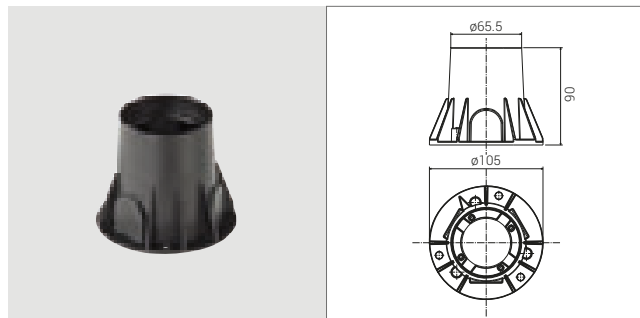

CODE DESCRIZIONE / DESCRIPTION

1411 Cassaforma / In-ground box $\phi 70$ mm

Cassaforma in tecnopolimero stabilizzato a interrare o da parete.

In-ground box in waterproof technopolymer.

CORPO LAMPADA | LIGHT BODY $\phi 70$ mm

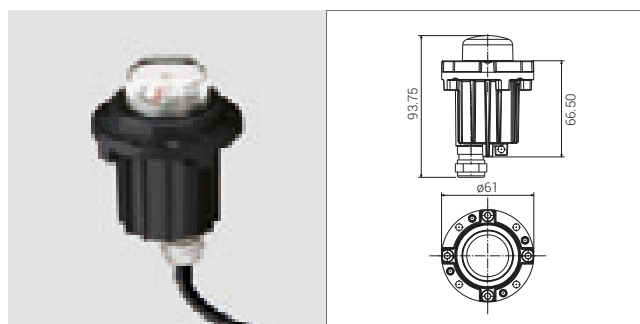

Alluminio - Aluminium

Code + Tonality

CODE	LAMP	W	lm	Nominali-Real output
1415	○ Led	1/24V DC	105	1x23
1416	○ Led	3/24V DC	185	1x40

Driver OUT.

24V DC per collegamento in parallelo. Carico max. 2000 Kg se montata su controscassa Goccia. IP 67 con calotte / Classe III \triangleleft / IK 10 CRI 80 / Driver OUT

CE

Tonalità 3000K o 4000K.

Aggiungere 3K o 4K dopo il codice.

Driver OUT.

24V DC for parallel connection. Max load pressure 2000 Kg if installed on Goccia in-ground box. IP 67 with canopies / Class III \triangleleft / IK 10 CRI 80 / Driver OUT

CE

Color temperature available 3000K or 4000K. Add 3K or 4K to the code.



INOX AISI 316L - AISI 316L stainless steel

Code + Tonality

CODE	LAMP	W	lm	Nominali-Real output
1481	○ Led	1/24V DC	105	1x23
1484	○ Led	3/24V DC	185	1x40

Stesse caratteristiche degli art. 1415-1416.

Same features as codes 1415-1416.

CALOTTE DI CHIUSURA | COVERING CANOPIES 70 mm

Alluminio / Aluminium

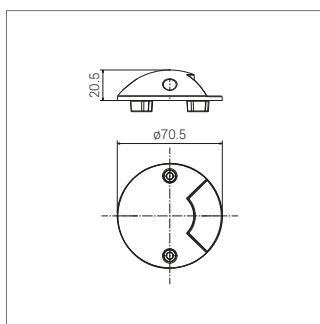
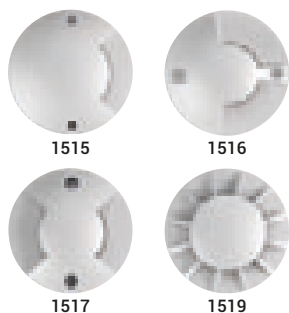

Alluminio - Aluminium

Code + Colour

CODE	DESCRIZIONE / DESCRIPTION	GM
1515*	1 faccia / 1 window	
1516*	2 facce 180° / 2 windows 180°	
1517*	2 facce 90° / 2 windows 90°	
1519*	Luce a 360° / 360° Light	

INOX AISI 316L - AISI 316L stainless steel

Code + Colour

CODE	DESCRIZIONE / DESCRIPTION	IN
1591*	1 faccia / 1 window	
1593*	2 facce 90° / 2 windows 90°	
1594*	Luce a 360° / 360° Light	

INOX Aisi 316L / Stainless Steel

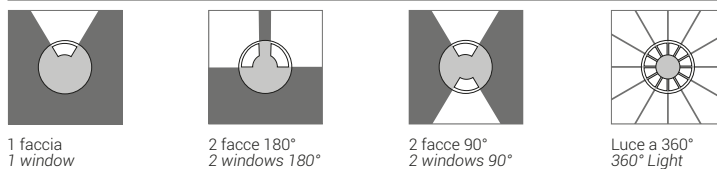

1 faccia
1 window

2 facce 180°
2 windows 180°

2 facce 90°
2 windows 90°

Luce a 360°
360° Light

A richiesta l'insieme corpo lampada+calotta viene fornito montato e sigillato.
The set light body+canopy can be supplied assembled and sealed.

Curve fotometriche: vedi capitolo specifico. Classe Energetica: vedi capitolo specifico.
Photometric data: go to relevant chapter. Energy class: go to code index.

PASSUM $\phi 125$

Sidewards

Incasso a terra o parete, luce radente
Ground + wall recessed for surface light



CASSAFORMA | IN-GROUND BOX

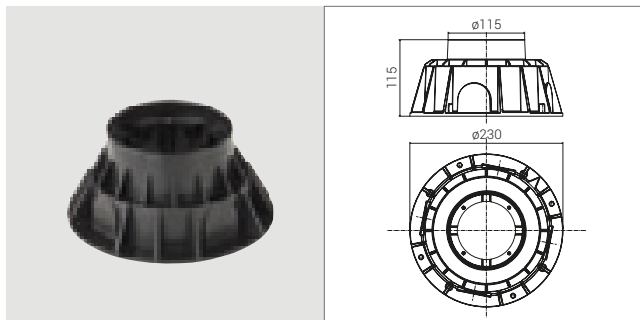

CODE DESCRIZIONE / DESCRIPTION

1421 Cassaforma / In-ground box $\phi 125$ mm

Cassaforma in tecnopolimero stabilizzato a interrare o da parete. *In-ground box in waterproof technopolymer.*

CORPO LAMPADA | LIGHT BODY $\phi 125$ mm

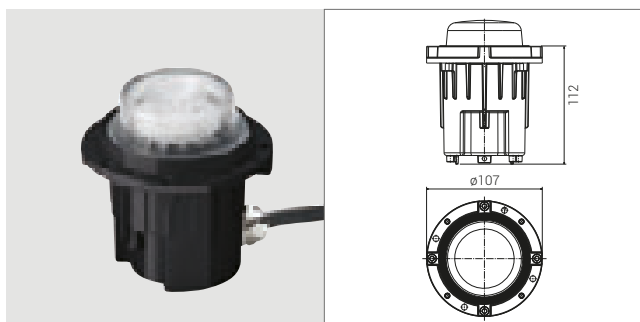

Alluminio - Aluminium

Code + Tonality

CODE LAMP W lm Nominali-Real output

1427 \bigcirc Led 4/230V 380 1x48

Carico max. 2000 Kg se montata su controcassa Goccia.
IP 67 con calotte / Classe I / IK 10
CRI 80 / Driver IN / 350 mA
230V / 50 Hz / 24V DC a richiesta
CE

Tonalità 3000K o 4000K.
Aggiungere 3K o 4K dopo il codice.

Max load pressure 2000 Kg if installed on Goccia in-ground box.

*IP 67 with canopies / Class I / IK 10
CRI 80 / Driver IN / 350 mA
230V / 50 Hz / 24V DC on request
CE*

Color temperature available 3000K or 4000K. Add 3K or 4K to the code.



INOX AISI 316L - AISI 316L stainless steel

Code + Tonality

CODE LAMP W lm Nominali-Real output

NEW 1485 \bigcirc Led 4/230V 380 1x48

Stesse caratteristiche dell'art. 1427.

Same features as code 1427.

CALOTTE DI CHIUSURA | COVERING CANOPIES 125 mm

Alluminio / Aluminium

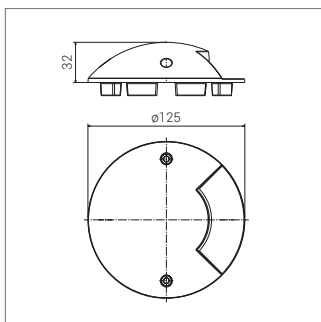
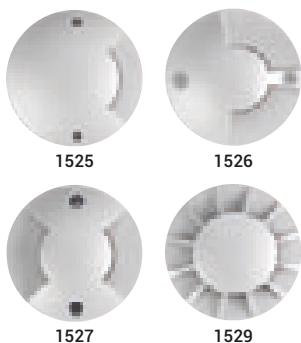

Alluminio - Aluminium

Code + Colour

CODE DESCRIZIONE / DESCRIPTION

1525* 1 faccia / 1 window

1526* 2 facce 180° / 2 windows 180°

1527* 2 facce 90° / 2 windows 90°

1529* Luce a 360° / 360° Light

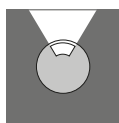

1 faccia
1 window

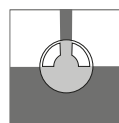

2 facce 180°
2 windows 180°

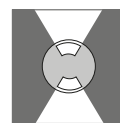

2 facce 90°
2 windows 90°

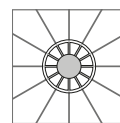

Luce a 360°
360° Light

A richiesta l'insieme corpo lampada+calotta viene fornito montato e sigillato.
The set light body+canopy can be supplied assembled and sealed.

Curve fotometriche: vedi capitolo specifico. Classe Energetica: vedi capitolo specifico.
Photometric data: go to relevant chapter. Energy class: go to code index.

PASSUM ø180

Sidewards

Incasso a terra o parete, luce radente
Ground + wall recessed for surface light



CASSAFORMA | IN-GROUND BOX

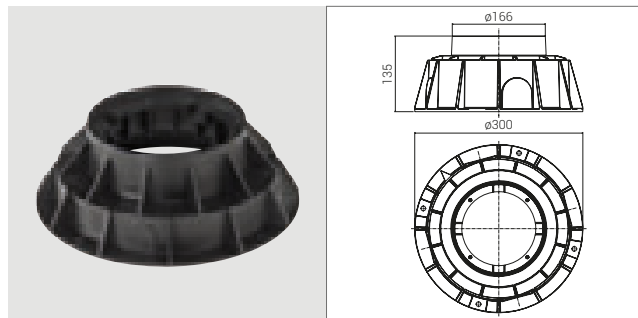

CODE DESCRIZIONE / DESCRIPTION

1431 Cassaforma / In-ground box ø 180 mm

Cassaforma in tecnopolimero stabilizzato a interrare o da parete.

In-ground box in waterproof technopolymer.

CORPO LAMPADA | LIGHT BODY ø 180 mm

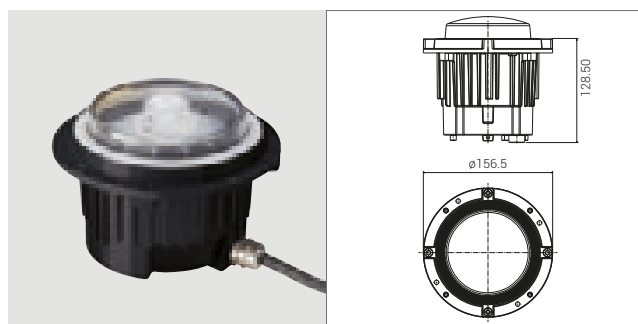

Alluminio - Aluminium

Code + Tonality

CODE	LAMP	W	lm Nominali-Real output
1436	○ Led	9,5/230V	1200 1x50

Carico max. 2000 Kg se montata su controcassa Goccia.

IP 67 con calotte / Classe I / IK 10
CRI 80 / Driver IN / 350 mA
230V / 50 Hz / 24V DC a richiesta

CE

Tonalità 3000K o 4000K.

Aggiungere 3K o 4K dopo il codice.

Max load pressure 2000 Kg if installed on Goccia in-ground box.

IP 67 with canopies / Class I / IK 10
CRI 80 / Driver IN / 350 mA
230V / 50 Hz / 24V DC on request

CE

Color temperature available 3000K or 4000K. Add 3K or 4K to the code.



INOX AISI 316L - AISI 316L stainless steel

Code + Tonality

CODE	LAMP	W	lm Nominali-Real output
1487	○ Led	9,5/230V	1200 1x50

Stesse caratteristiche dell'art. 1436.

Same features as code 1436.

CALOTTE DI CHIUSURA | COVERING CANOPIES ø 180 mm

Code + Colour

Alluminio / Aluminium

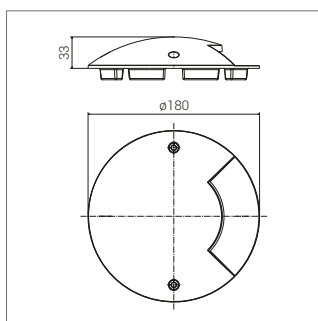
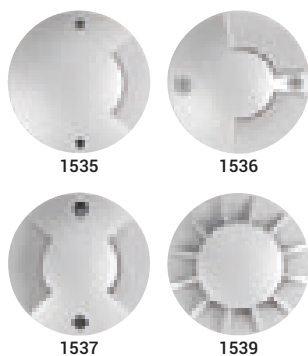

Alluminio - Aluminium

CODE DESCRIZIONE / DESCRIPTION

GM

1535* 1 faccia / 1 window

1536* 2 facce 180° / 2 windows 180°

1537* 2 facce 90° / 2 windows 90°

1539* Luce a 360° / 360° Light

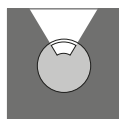

1 faccia
1 window

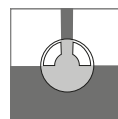

2 facce 180°
2 windows 180°

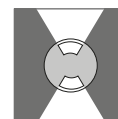

2 facce 90°
2 windows 90°

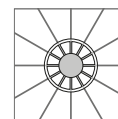

Luce a 360°
360° Light

A richiesta l'insieme corpo lampada+calotta viene fornito montato e sigillato.
The set light body+canopy can be supplied assembled and sealed.

Curve fotometriche: vedi capitolo specifico. Classe Energetica: vedi capitolo specifico.
Photometric data: go to relevant chapter. Energy class: go to code index.





PASSUM $\phi 180$ orientabile/adjustable

Incasso a terra o parete, luce orientabile
Ground + wall recessed adjustable optic



CASSAFORMA | IN-GROUND BOX

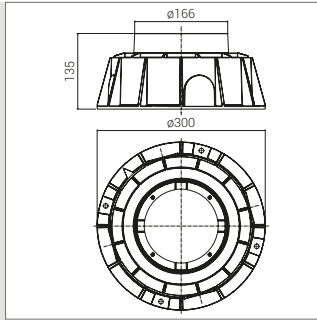

CODE DESCRIZIONE / DESCRIPTION

1431 Cassaforma / In-ground box $\phi 180$ mm

Cassaforma in tecnopolimero stabilizzato a interrare o da parete.

In-ground box in waterproof technopolymer.

CORPO LAMPADA CON CALOTTA E LUCE ORIENTABILE | SET LIGHT BODY+COVERING CANOPY AND ADJUSTABLE OPTIC $\phi 180$ mm

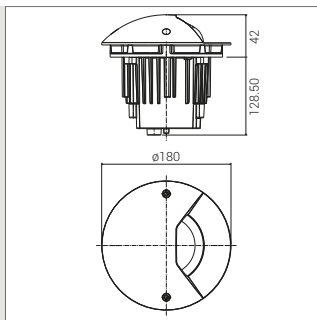

Alluminio - Aluminium

Code + Tonality

CODE LAMP W lm Nominali-Real output

1438 \bigcirc Led 8/230V 750 451

Insieme corpo lampada+calotta.
Ottica orientabile da 0° a +45°. Fascio luminoso: 40° di serie, 12° su richiesta. Coppa in policarbonato anti UV. Carico max. 2000 Kg. IP 67 / Classe I / IK 10 CRI 80 / Driver IN / 500 mA 230V / 50 Hz **CE**
Tonalità 3000K o 4000K.
Aggiungere 3K o 4K dopo il codice.

Light body+covering canopy supplied together.
Adjustable optic directed toward 0 and 45° up. Angle beam: 40° standard / 12° on request.
Clear polycarbonate diffuser UV resistant. Max load pressure 2000 Kg. IP 67 / Class I / IK 10 CRI 80 / Driver IN / 500 mA 230V / 50 Hz **CE**
Color temperature available 3000K or 4000K. Add 3K or 4K to the code.

INOX AISI 316L - AISI 316L stainless steel

Code + Tonality

CODE LAMP W lm Nominali-Real output

NEW 1488 \bigcirc Led 8/230V 750 451

Stesse caratteristiche dell'art. 1438.

Same features as code 1438.

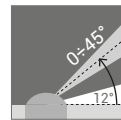

option
aggiungere 12 al codice
add 12 to the code

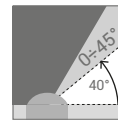

standard

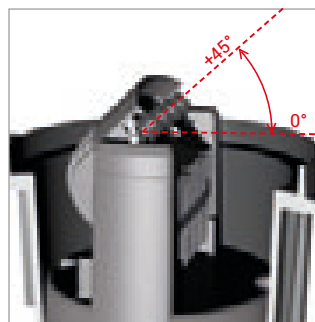
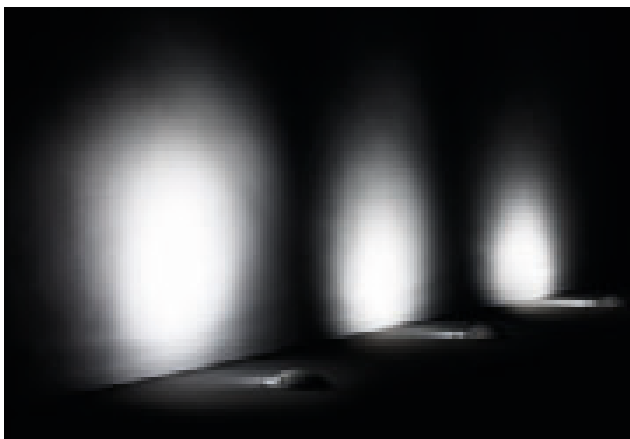















OTTICA ORIENTABILE

Il gruppo ottico è facilmente regolabile sul piano verticale e consente di orientare la luce da 0° a +45° nella direzione desiderata.













ADJUSTABLE OPTIC

The optic unit is easily adjustable and permits to orient the light at the ground surface until 45° upwards.



PASSUM UP

Ø mm	Cassaforma In-ground box	Corpo - Light body Optica - Optic	W	IK	Fascio luminoso Angle beam	Driver	T° Vetro Glass	Carico Load pressure Kg	Calp/ carrabile Walk/drive over	Flange Flanges	Antiscivolo Skidproof
70	 Ø 105 x 90	<div style="display: flex; justify-content: space-around;"> <div style="text-align: center;"> <p>Alluminio Aluminium</p>  </div> <div style="text-align: center;"> <p>INOX Stainless Steel</p>  </div> </div> <p>Fisso - Fix</p>	1/3 LED	8	18°/38°/90°	OUT	≤40°	1000		<p>Alluminio Aluminium</p>  <p>INOX Stainless Steel</p> 	-
125	 Ø 230 x 115	<div style="display: flex; justify-content: space-around;"> <div style="text-align: center;"> <p>Alluminio Aluminium</p>  </div> <div style="text-align: center;"> <p>INOX Stainless Steel</p>  </div> </div> <p>Basculante Adjustable</p>	4 LED	10	18°/38°/90°	IN	≤40°	2000		<p>Alluminio Aluminium</p>  <p>INOX Stainless Steel</p> 	-
			5 GU 10	10	18°/38°/90°	IN	≤40°	2000			
125 ultraflat	 Ø 160 x 70	<p>Alluminio - Aluminium</p>  <p>Fisso - Fix</p>	8 LED	10	90°	IN	≤40°	2000		<p>Alluminio Aluminium</p>  <p>INOX Stainless Steel</p> 	-
180	 Ø 300 x 135	<div style="display: flex; justify-content: space-around;"> <div style="text-align: center;"> <p>Alluminio Aluminium</p>  </div> <div style="text-align: center;"> <p>INOX Stainless Steel</p>  </div> </div> <p>Basculante Adjustable</p>	9,5 LED	10	18°/38°/90°	IN	≤40°	3500		<p>Alluminio Aluminium</p>  <p>INOX Stainless Steel</p> 	OPTION
			7-8 GU 10	10	18°/38°/90°	IN	≤40°	3500			
245	 Ø 360 x 286,8	<p>Alluminio - Aluminium</p>  <p>Basculante Adjustable</p>	29 LED	10	18°/38°/90°	IN	≤40°	3500		<p>Alluminio Aluminium</p>  <p>INOX Stainless Steel</p> 	OPTION
			70 Ioduri Metallici Metal Halide	10	18°/38°	IN	≤40°	3500			
			30 E27	10	90°	IN	≤40°	3500			
245 RGB W	 Ø 360 x 286,8	<p>Alluminio - Aluminium</p>  <p>Basculante Adjustable</p>	20 LED	10	40°	IN	≤40°	3500		<p>Alluminio Aluminium</p>  <p>INOX Stainless Steel</p> 	OPTION

PASSUM SIDEWARDS

Ø mm	Cassaforma In-ground box	Corpo - Light body Ottica - Optic	Sporgenza Canopy height mm	W	IK	Driver	T° Vetro Glass	Carico Load pressure Kg	Calp/ carrabile Walk/drive over	Calotte Canopies
70	 Ø 105 x 90	<p>Alluminio Aluminium INOX Stainless Steel</p>  <p>Fisso - Fix</p>	20,5	1/3 LED	8	OUT	≤40°	2000		<p>Alluminio - Aluminium</p>  <p>INOX - Stainless Steel</p> 
125	 Ø 230 x 115	<p>Alluminio Aluminium INOX Stainless Steel</p>  <p>Fisso - Fix</p>	32	4 LED	10	IN	≤40°	2000		<p>Alluminio - Aluminium</p> 
180	 Ø 300 x 135	<p>Alluminio Aluminium INOX Stainless Steel</p>  <p>Fisso - Fix</p>	33	9,5 LED	10	IN	≤40°	2000		<p>Alluminio - Aluminium</p> 

PASSUM orientabile/adjustable

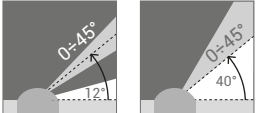
Ø mm	Cassaforma In-ground box	Corpo - Light body Ottica - Optic	Sporgenza Canopy height mm	W	IK	Driver	T° Vetro Glass	Carico Load pressure Kg	Calp/ carrabile Walk/drive over	Fascio luminoso / inclinazione Angle beam / oriented
180	 Ø 300 x 135	<p>Alluminio Aluminium INOX Stainless Steel</p>  <p>Orientabile Adjustable</p>	43	8 LED	10	IN	≤40°	2000		

PASSUM DRIVERS

ALIMENTATORI 24V DC PER COLLEGAMENTO IN PARALLELO 24V DC DRIVER FOR PARALLEL CONNECTION

CODE	Volt DC	W	IP	Dimensioni - Dimensions mm
1952	24	18	67	120 x 30 x 22
1954	24	35	67	148 x 40 x 30
1955	24	60	67	162.5 x 42.5 x 32



STANDING

PALETTO DA GIARDINO
GARDEN POST LIGHTS



Il design essenziale, la costruzione interamente in alluminio, la sorgente luminosa a led conferiscono a questa piccola piantana da giardino la capacità di inserirsi discretamente, ma con personalità, in ogni ambiente.

La struttura robusta ha consentito di ridurre la sezione a soli 73x86 mm, permettendo alla base di fissaggio di non sporgere dal profilo.

STANDING è stata progettata per diffondere tutta la luce verso il basso per illuminare percorsi, camminamenti e viali di accesso, ma può svolgere una doppia funzione di rischiaramento per giardini e aiuole.

Its essential design, aluminium structure, and LED light source allow this post light to fit into your garden discretely yet with personality.

Its sturdy structure has made it possible to reduce its cross-section to just 73x86 mm, thereby preventing its base from protruding from its profile.

STANDING is a downlight for walkways and driveways and can be used for lighting gardens and flower beds.

STANDING

Paletti da giardino
Garden post lights

CARATTERISTICHE GENERALI

- Piccola piantana da giardino a forma di parallelepipedo che proietta tutta la luce verso il basso.
- **Struttura:** interamente in lega di alluminio primario a basso tenore di rame. Luce frontale, protetta da aletta antiabbagliamento, progettata per illuminare camminamenti, passaggi e vialetti.
- La struttura consente l'inserimento sul retro di un secondo corpo illuminante a luce radente e diffusa da 8W.
- **Sorgenti luminose:** schede led di nuova generazione alimentate direttamente a tensione di rete 230V. Vita garantita: 60.000 h con max scadimento del 20%. Driver incorporato nella scheda led.
- Fornito di 0,5 mt di cavo H05RN-F in uscita dal testa palo. Connessione stagna diretta o entra/esci mediante connettori stagni disponibili come accessori.
- **Finitura:** su alluminio, decappaggio + fosfocromatazione + fondo epossidico + verniciatura con polveri epossidiche stabilizzate anti UV.
- Costruito in conformità alle norme europee EN 60598-1:2015 **CE**

GENERAL FEATURES

- *Parallelepiped-shaped garden downlights.*
- **Structure:** fully made of primary aluminium alloy with low copper content. The front light, protected by an antidazzle louvre, is designed for walkways and driveways.
- *Its structure allows another side-light or diffused light luminaires 8W to be installed at the back.*
- **Light sources:** state-of-the-art LEDs powered by 230V mains voltage. Minimum lifetime: 60,000 h with max 20% degradation. Driver inside the LED board.
- *Equipped with a 0,5 m H05RN-F cable coming out from the top cover. Watertight direct or I/O connection through optional watertight connectors.*
- **Finish:** on aluminium, pickling + phosphochrome + epoxy basic coating + UV resistant stabilised epoxy powder coating.
- *Manufactured in compliance with European standards EN 60598-1:2015 **CE***

LUCE VERSO IL BASSO

La luce led frontale viene direzionata verso il basso ed è protetta da aletta antiabbagliante.

DOWNWARD LIGHT

The front LED light is directed downwards and is protected by an antidazzle louvre.

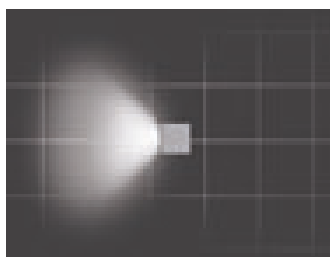
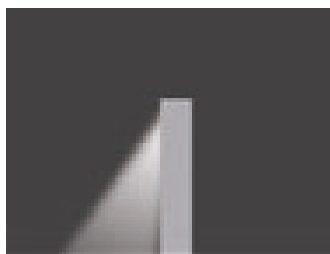

ALETTA ANTIABBAGLIANTE

L'aletta anteriore dirige la luce verso il basso ed evita l'abbagliamento.

ANTIDAZZLE LOUVRE

The front louvre directs the light downwards for an antidazzle effect.



CABLAGGIO ENTRA/ESCI

Con l'apposito giunto stagno a Y cod. 1942, fornito come accessorio, è possibile effettuare il cablaggio passante.

I/O WIRING

The optional Y-connector (code 1942) allows for through wiring.



CABLAGGIO INTERNO

Il cablaggio è interno alla struttura tramite gli appositi giunti cod. 1941 e 1942 forniti separatamente.

INTERNAL WIRING

The wiring is inside the pole. The connections (codes 1941 and 1942) are supplied separately.



STANDING



STANDING

Code + Colour + Tonality

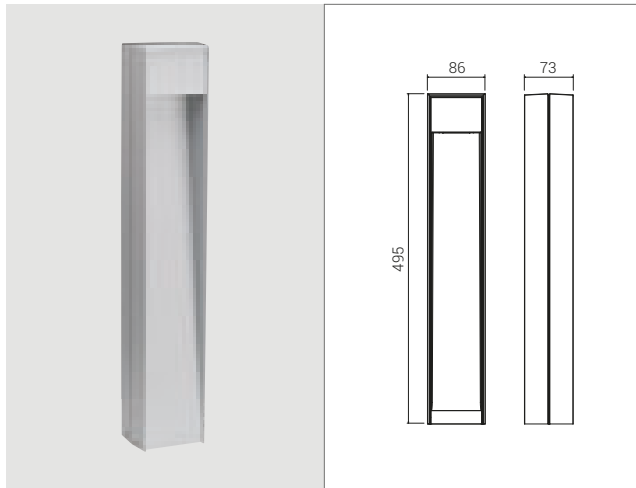

CODE	LAMP	W	lm Nominali-Real output	GR	GM
NEW 5526*	○ Led	8	800 355		

Paletto completo in alluminio.
 IP 65 / Classe I / IK 10
 CRI 85 / Driver IN
 230V / 50 Hz
€€
 Tonalità 3000K o 4000K.
 Aggiungere 3K o 4K al codice dopo il colore.

Aluminium post.
 IP 65 / Class I / IK 10
 CRI 85 / Driver IN
 230V / 50 Hz
€€
 Color temperature available 3000K or 4000K. Add 3K or 4K to the code after the color.

GIUNTI STAGNI | WATERTIGHT CONNECTION BLOCKS



CODE	DESCRIZIONE / DESCRIPTION
1941	Giunto di connessione IP68 per cavi 3x2,5 mm ² <i>IP68 connection block for 3x2.5 mm² cables</i>



CODE	DESCRIZIONE / DESCRIPTION
1942	Giunto entra/esci per cavi 3x2,5 mm ² <i>Through wiring connection block for 3x2.5 mm² cables</i>

TIRAFONDI | ANCHORING SET

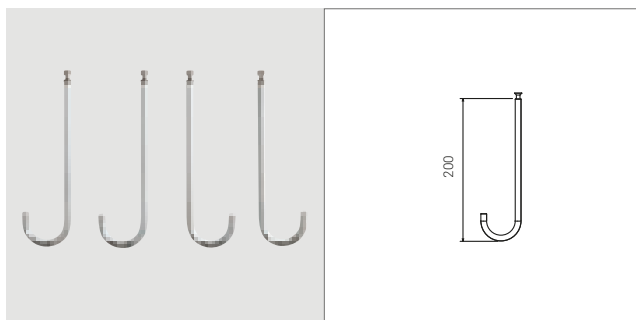

CODE	DESCRIZIONE / DESCRIPTION
5529	4 tirafondi / 4 anchors

Tirafondi in inox da fissare alla basetta del palo.

Stainless steel anchoring set for the post base.



COMPATTA

LAMPADE DA INCASSO A PARETE WALL RECESSED LAMPS



Con griglia
With guard



Compatta
8,5 W
LED

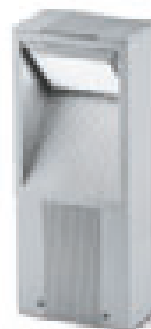

Piantana 1 luce
1-fitting post



Senza griglia
Without guard



Compatta
3x6,5 W
LED

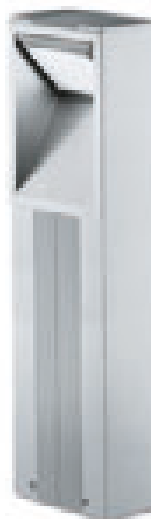

Piantana 1/2 luci
1/2-fitting post

COMPATTA è un apparecchio da incasso robusto dalla linea pulita ed essenziale senza viti a vista. È disponibile senza griglia per un'illuminazione diretta verso il basso e con griglia antiabbagliante. La piantana è una struttura prismatica lineare con lampada a sporgenza zero, che offre anche l'opportunità di illuminare in due direzioni opposte: un viale da un lato e un'aiuola dall'altro.

COMPATTA is a robust recessed wall luminaire of linear design without visible screws. The COMPATTA is available without grid for a direct illumination oriented to the floor or with anti-dazzle grid. The garden post is a linear prismatic structure that allows a perfectly flush fitting of the COMPATTA and for two opposite luminous surfaces to light up a pathway on one side and a tree or a wall on the opposite side. The anti-dazzle grid will instead illuminate downwards.



COMPATTA

Lampade da incasso
Recessed lamps

CARATTERISTICHE GENERALI

- Apparecchio da incasso a parete per esterno.
- **Struttura:** corpo in alluminio pressofuso a basso tenore di rame, completo di scatola porta accessori di cablaggio. Griglia antiabbagliante in alluminio pressofuso. Diffusore in vetro temprato opale o trasparente. Viti Inox a brugola.
- Controcassa in polimero predisposto per ingresso cavi e fissaggio apparecchio.
- Ingresso cavi dal retro.
- **Sorgenti luminose** a basso consumo e a Led di nuova generazione con vita garantita 60.000 h con successivo scadimento max del 20%. Driver 230 V incorporato.
- **Piantane** in alluminio estruso con piede a scomparsa e testa palo in alluminio pressofuso, con cassetta di derivazione incorporata.
- Disponibile anche per 2 apparecchi Compatta, con doppia illuminazione fronte/retro.
- **Finitura:** su alluminio, decappaggio + fosfocromatazione + fondo epossidico + verniciatura con polveri epossidiche stabilizzate anti UV.
- Costruito in conformità alle norme europee EN 60598-1:2015 CE

GENERAL FEATURES

- Wall recessed fitting for outdoors
- **Structure:** die-cast aluminium with low copper content, complete with wiring accessories box. Antidazzle, die-cast aluminium guard. Opal or transparent tempered glass diffuser. Stainless steel Allen key screws.
- Polymer backbox for cable entry and fitting fixing.
- Cable entry from the back.
- Low consumption **light sources** and new generation LEDs with minimum life 60,000 h with subsequent deterioration max 20%. 230 V driver inside.
- **Posts** in extruded aluminium with retractable base and top cover in die-cast aluminium, with junction box inside.
- Also available for 2 Compatta fittings, with double front/back illumination.
- **Finish:** on aluminium, pickling + phosphochrome + epoxy basic coating + UV resistant stabilised epoxy powder coating.
- Manufactured in compliance with European standards EN 60598-1:2015 CE

CONTROCASSA

La speciale controcassa in tecnopolimero consente di predisporre l'incasso nelle murature anche di cemento armato. L'apparecchio verrà poi installato a parete finita.

BACKBOX

The special technopolymer backbox allows you to set recessing on walls, even on reinforced concrete. The fitting is then installed on a finished wall.

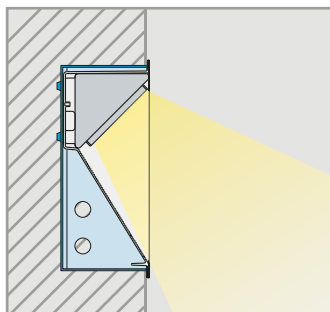

GRIGLIA ANTIABBAGLIANTE

L'inclinazione verso il basso del riflettore evita l'abbagliamento. La griglia in alluminio pressofuso lo riduce ulteriormente evitando qualsiasi dispersione della luce.

ANTIDAZZLE GUARD

The downward inclination of the reflector prevents glare. The die-cast aluminium guard reduces it even further, preventing any light dispersion.

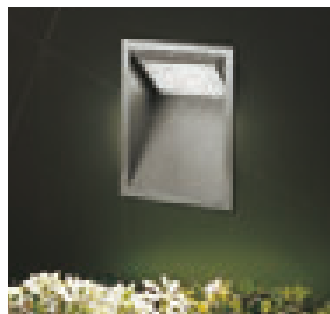

PIANTANA CON DOPPIA LUCE

La particolare piantana per 2 apparecchi Compatta da H 900 mm, consente la doppia illuminazione frontale e posteriore, per illuminare contemporaneamente il camminamento e il giardino posteriore.

DOUBLE LIGHT POSTS

The special post for 2 H 900 mm Compatta fittings allows for double front and back illumination to simultaneously light the walkway and the back garden.



COMPATTA

Lampade da incasso a parete
Wall recessed lamps



SENZA GRIGLIA | WITHOUT GUARD

Code + Colour

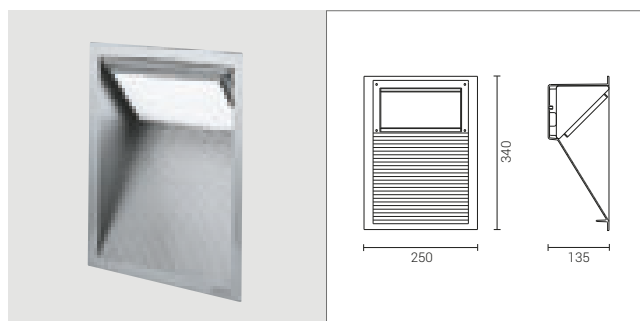

CODE	LAMP	W	GR	GM
------	------	---	----	----

5022*	G24d-3	26		
--------------	--------	----	--	--

5024*	Rx7s	70		
--------------	------	----	--	--

Diffusore in vetro temprato.
IP 65 / Classe II / IK 08

Tempered opal glass diffuser.
IP 65 / Class II / IK 08

CON GRIGLIA | WITH GUARD

Code + Colour

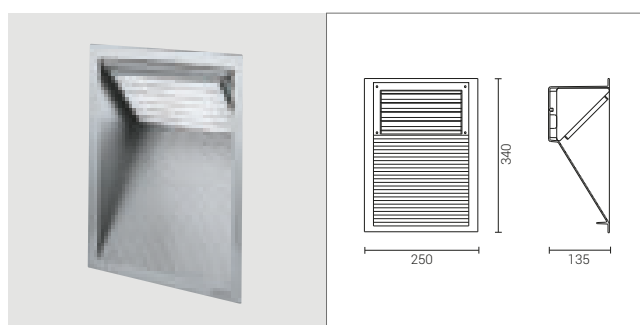

CODE	LAMP	W	GR	GM
------	------	---	----	----

5032*	G24d-3	26		
--------------	--------	----	--	--

5034*	Rx7s	70		
--------------	------	----	--	--

Griglia antiabbagliante in alluminio pressofuso.
Diffusore in vetro temprato.
IP 65 / Classe II / IK 10

Anti-dazzle guard in die-cast aluminium.
Tempered opal glass diffuser.
IP 65 / Class II / IK 10

LED

Code + Colour + Tonality

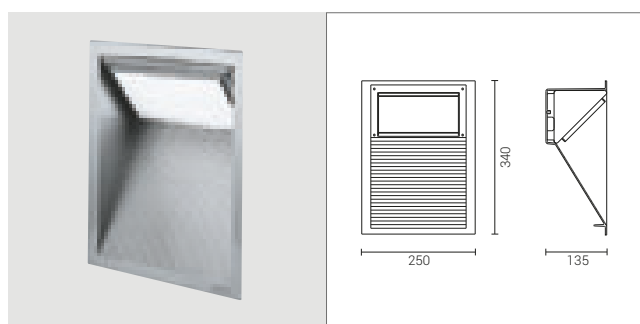

CODE	LAMP	W	Im Nominali-Real output	GR	GM
------	------	---	-------------------------	----	----

5026*	Led	8,5	850 419		
--------------	-----	-----	---------	--	--

Diffusore opale in vetro temprato.
3 moduli lineari led 24V tensione costante.
Apertura del fascio luminoso: 90°.
IP 65 / Classe II / IK 08
CRI 85 / Driver IN / 350 mA
230V / 50 Hz

Diffuser in opal tempered glass.
3 linear Led modules 24V.
90° angle beam.
IP 65 / Class II / IK 08
CRI 85 / Driver IN / 350 mA
230V / 50 Hz

Tonalità 3000K o 4000K. Aggiungere 3K o 4K al codice dopo il colore.

Color temperature available 3000K or 4000K. Add 3K or 4K to the code after the color.

Code + Colour + Tonality

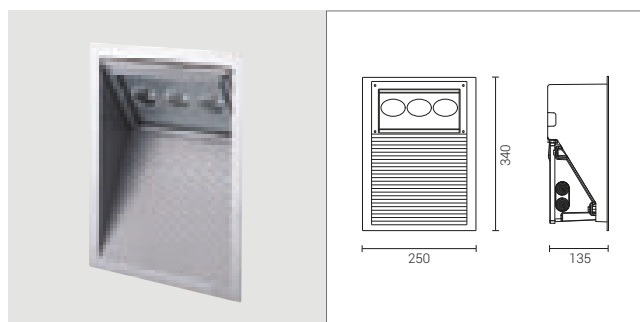

CODE	LAMP	W	Im Nominali-Real output	GR	GM
------	------	---	-------------------------	----	----

5025*	Led	3x6,5	1980 1144		
--------------	-----	-------	-----------	--	--

Diffusore trasparente in vetro temprato.
3 gruppi Led da 6,5W e 660 lumen ciascuno. 19,5W e 1980 lumen totali.
IP 65 / Classe II / IK 08
CRI 85 / Driver IN / 350 mA
230V / 50 Hz

Clear tempered glass.
3 led units 6,5 W 660 lumen each.
19,5W 1980 lumen totally.
IP 65 / Class II / IK 08
CRI 85 / Driver IN / 350 mA
230V / 50 Hz

Tonalità 3000K o 4000K. Aggiungere 3K o 4K al codice dopo il colore.

Color temperature available 3000K or 4000K. Add 3K or 4K to the code after the color.

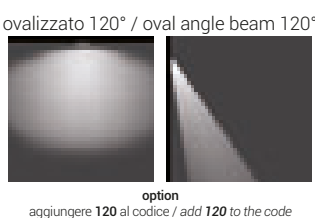
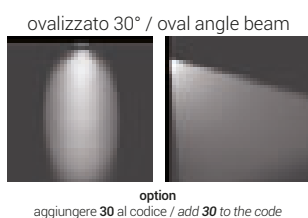
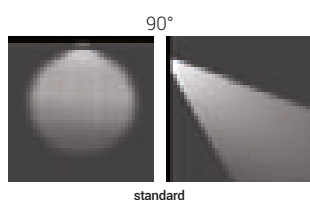

I due fasci ovalizzati si ottengono girando di 90° la stessa lente Fresnel.
The two oval angle beams come by the same Fresnel lens rotated of 90°.

COMPATTA

CONTROCASSA | BACKBOX

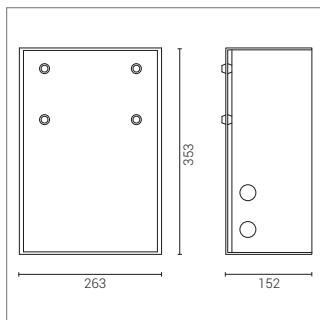

CODE DESCRIZIONE / DESCRIPTION

5002 Controcassa / Backbox

Struttura in tecnopolimero.
Predisposizione per ingresso cavi e
fissaggio Compatta.

*Tecnopolimer body.
Equipped with cable entry and Compatta
inserting accessories.*

PIANTANA | GARDEN POST

Code + Colour

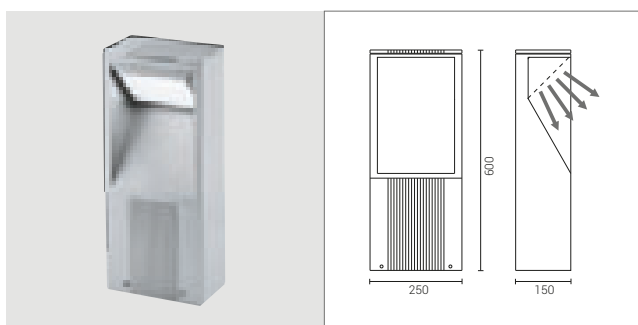

CODE DESCRIZIONE / DESCRIPTION

GR GM

3721* Solo piantana per 1 Compatta / Post for 1 Compatta

Struttura in alluminio estruso.
Piede a scomparsa e testa palo in alluminio
pressofuso.
Cassetta di derivazione incassata nel palo.
Solo palo, apparecchi Compatta forniti a
parte.

*Post in extruded aluminium.
Base and top cover in die-cast aluminium.
Recessed junction box included.*

*Post only, Compatta fitting is supplied
separately.
Class II *

Classe II 
CE

CE

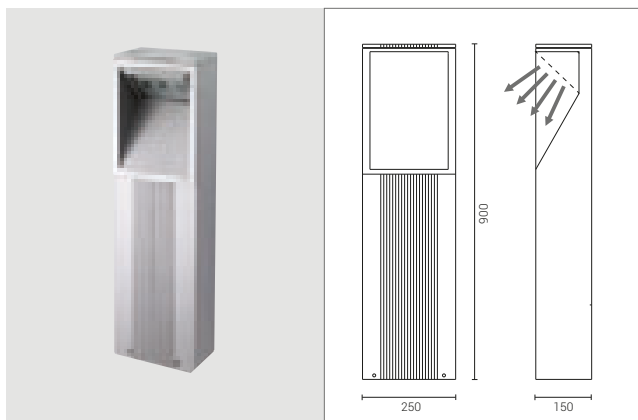

CODE DESCRIZIONE / DESCRIPTION

GR GM

3723* Solo piantana per 1 Compatta / Post for 1 Compatta

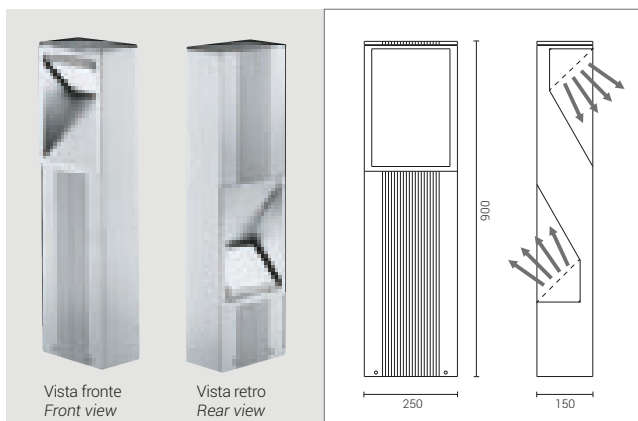

CODE DESCRIZIONE / DESCRIPTION

GR GM

3722* Solo piantana per 2 Compatta / Post for 2 Compatta

Apparecchio Compatta installabile
orientato verso l'alto o verso il basso.
Solo palo, apparecchi Compatta forniti a
parte.

*Compatta fitting can be oriented upwards
or downwards.*

*Post only, Compatta fitting is supplied
separately.
Class II *

Classe II 
CE

CE

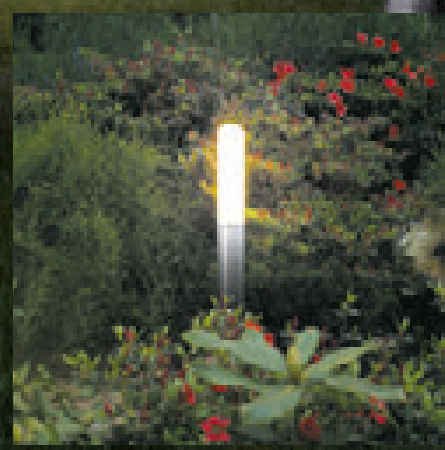

SISTEMA PER PALI Ø60 Ø60 BOLLARDS COMBINATION

CANTHARELLUS i-LUX i-MAGO i-DEA
LAMPADE PER PALETTI Ø60 DA GIARDINO
LUMINAIRES FOR GARDEN POLES Ø60

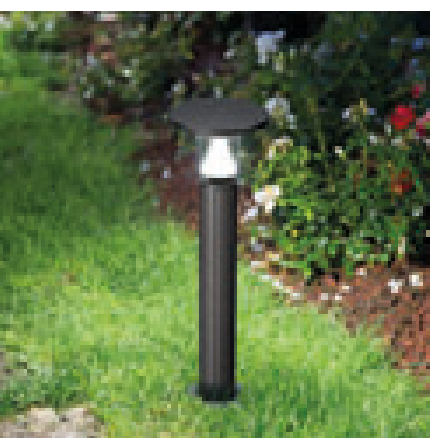

Il Sistema Completo per paletti Ø 60 da giardino di Goccia Illuminazione comprende le serie CANTHARELLUS, i-LUX, i-MAGO e i-DEA, composte da lampade a stelo che hanno in comune una gamma completa di pali Ø 60 in alluminio o Inox e accessori dedicati e una grande componibilità, per l'illuminazione in giardini e parchi. La linea stilizzata e le soluzioni tecniche innovative caratterizzano tutte le Serie.









CANTHARELLUS è un intrigante testa palo a led, declinato in 2 dimensioni, che orienta la luce verso il basso; I-LUX è una lampada con coppa allungata, con varie versioni e accessori. I-MAGO emette verso il basso la luce di 4 Led di potenza, ideale per l'illuminazione di percorsi. I-DEA evoca la poesia dei preziosi paralumi in policarbonato colorato o in vetro lavorato a mano.

A wide range of bollards with 60 mm diameter pole including CANTHARELLUS, I-LUX, I-MAGO and I-DEA. Different aspect but made to be installed on the same poles in aluminium or stainless steel 316L. The essential design and its modular system allow such bollards to be installed in parkways and gardens.

CANTHARELLUS is an intrigant lighting top made to orient the light towards the ground and comes in two dimensions. I-LUX is a narrow bollard with different versions. I-MAGO an exciting clear diffuser that makes architectural any type of environment. I-DEA recalls the poetry of precious lampshades in polycarbonate and hand-made crystal glass.

Il sistema completo per pali ø60

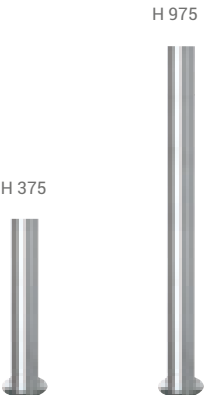
The complete system for poles ø60

	CANTHARELLUS LED ALLUMINIO LED ALUMINIUM	i-LUX ALLUMINIO ALUMINIUM	INOX STAINLESS STEEL
COPPE LAMP SHADES			
CORPI LAMPADA LIGHT BODIES	 <p>ø 150 NEW</p> <p>ø 200 NEW</p>	 <p>Opale Opal</p> <p>Frangiluce regolabile Antidazzing deflector</p> <p>Frangiluce Louvers</p>	 <p>Opale Opal</p> <p>Frangiluce regolabile Antidazzing deflector</p> <p>Frangiluce Louvers</p>
BRACCI A MURO ARMS			
PALI POLES		 <p>H 375</p> <p>H 800</p> <p>H 1875</p> <p>Standard pole ø 60</p>	 <p>H 375</p> <p>H 975</p>
PIASTRA CON TIRAFONDI PLATE WITH ANCHORING SET			
PICCHETTO SPIKE			

i-MAGO

LED ALLUMINIO
ALUMINIUM LED

LED INOX
LED STAINLESS STEEL

i-DEA

ALLUMINIO
ALUMINIUM

LED ALLUMINIO
LED ALUMINIUM

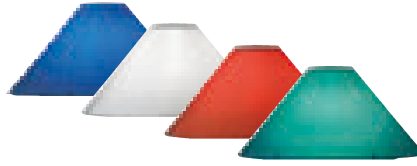

i-DEA



i-DEA PREZIOSA

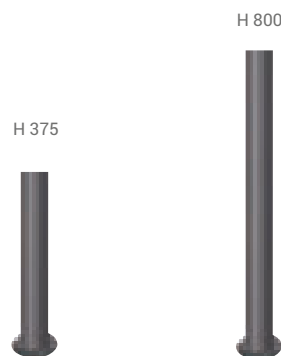
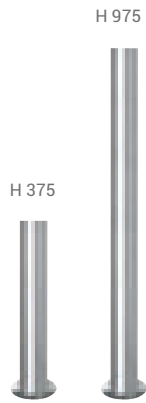
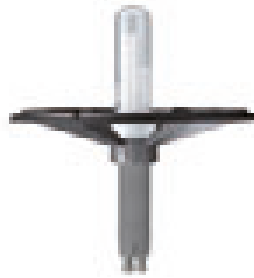



CANTHARELLUS

PALETTO DA GIARDINO
GARDEN POST LIGHTS



NEW
ø 150 LED



NEW
ø 200 LED

È un “funghetto” luminoso rivisitato in chiave contemporanea con tutti i vantaggi dei led. Progettato per dirigere tutta la luce verso il basso, è ideale per l'illuminazione di vialetti, percorsi e camminamenti nei giardini.

I led di ultima generazione consentono di ottenere un'elevata efficienza luminosa, che raggiunge 1000 e 2000 lumen, con diffusione a 360°.

CANTHARELLUS è disponibile in due dimensioni: ø 150 mm, perfetto per i pali bassi da 375 mm; ø 200 mm per i pali alti da 800 o 1875 mm. Il corpo lampada, unito alla scatola di cablaggio per agevolare l'installazione, è inseribile sia sugli appositi pali scanalati Goccia Illuminazione che sui normali pali di mercato da ø 60 mm.

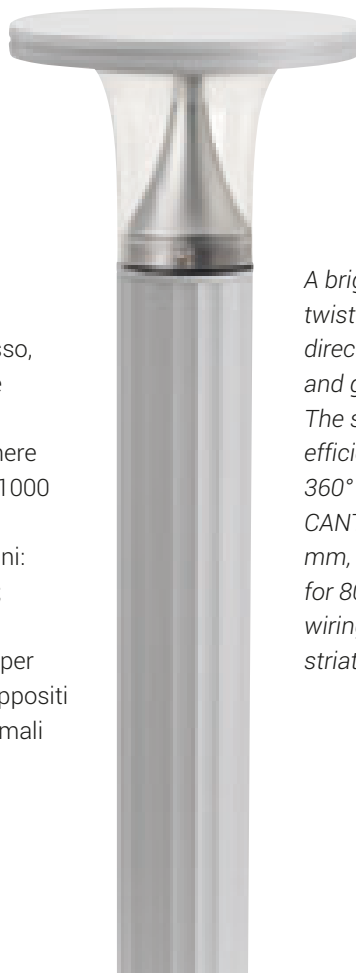

A bright garden “mushroom” with a contemporary twist and all the advantages of LEDs. Designed to direct all the light downwards. Ideal for driveways and garden walkways.

The state-of-the-art LEDs provide high lighting efficiency – up to 1000 and 2000 lumens – with a 360° diffusion.

CANTHARELLUS is available in two sizes: ø 150 mm, perfect for 375 mm posts, and ø 200 mm for 800 or 1875 mm posts. The lamp body and wiring box can be fitted to the Goccia Illuminazione striated posts or normal ø 60 mm posts.



CANTHARELLUS

Paletti da giardino
Bollards for garden

CARATTERISTICHE GENERALI

- Apparecchio da giardino a forma di fungo che proietta la luce verso il basso.
- Installazione su palo.
- **Struttura:** parte superiore e scocca in lega di alluminio primario a basso tenore di rame.
Coppa di protezione in policarbonato trasparente satinato. Diffusore interno in alluminio antiriflesso.
- Il corpo, completo di scatola di cablaggio, è disponibile in due dimensioni: \varnothing 150 e \varnothing 200 mm. È inseribile su pali scanalati in alluminio Goccia Illuminazione o su pali standard \varnothing 60 mm disponibili sul mercato.
- Il \varnothing 150 è consigliato per installazione sui pali di altezza 375 mm; il \varnothing 200 per pali da 800 o 1875 mm.
- **Sorgenti luminose:** led alimentato direttamente a tensione di rete 230V. Vita garantita 60.000 h con max scadimento del 20%. Driver incorporato nella scheda led.
- Cablaggio entra/esci mediante due bocchettoni PG11 inseriti nella scatola di cablaggio.
- **Finitura:** su alluminio, decappaggio + fosfocromatazione + fondo epossidico + verniciatura con polveri epossidiche stabilizzate anti UV.
- Costruito in conformità alle norme europee EN 60598-1:2015 **CE**

GENERAL FEATURES

- *Mushroom-shaped garden downlights.*
- *Installation on posts.*
- **Structure:** Upper part and body made of primary aluminium alloy with low copper content.
Clear satin polycarbonate diffuser. Anti-glare aluminium internal diffuser.
- *The body, equipped with a wiring box, is available in two sizes: \varnothing 150 and \varnothing 200 mm. It can be fitted to Goccia Illuminazione striated aluminium posts or standard \varnothing 60 mm posts available on the market.*
- *The \varnothing 150 version is recommended for 375 mm posts, and the \varnothing 200 version, for 800 or 1875 mm posts.*
- **Light sources:** LEDs powered by 230V mains voltage. Minimum lifetime: 60,000 h with max 20% degradation. Driver inside the LED board.
- *I/O wiring with two PG11 inlets in the wiring box.*
- **Finish:** on aluminium, pickling + phosphochrome + epoxy basic coating + UV resistant stabilised epoxy powder coating.
- *Manufactured in compliance with European standards EN 60598-1:2015 **CE***

RN BASSO

La forma a fungo consente di direzionare la luce verso il basso riducendo al minimo la dispersione verso l'alto.

LOW RN

The mushroom shape allows for directing the light downwards minimising upward light dispersion.

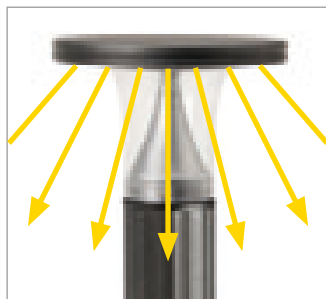

CABLAGGIO ENTRA/ESCI

Il corpo lampada è dotato di 2 bocchettoni per consentire l'alimentazione passante.

I/O WIRING

The lamp body is provided with 2 inlets for pass-through power cables.



COPERCHIO CONVESSO

La particolare forma del coperchio evita il ristagno dell'acqua.

ROUNDED COVER

This profile avoids water puddles.

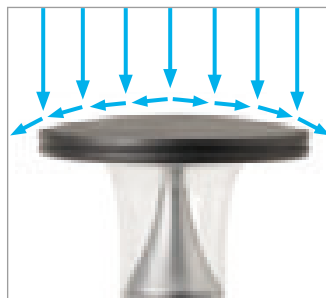

PALI IN ALLUMINIO

Pali in alluminio estruso con particolare forma a poliedro stondato di 16 lati. Disponibili in 3 altezze: 375, 800 e 1875 mm.

ALUMINIUM POSTS

Extruded aluminium posts with a rounded 16-gon shape. Three heights available: 375, 800, and 1875 mm.



ADATTATORE PER PALI \varnothing 60 mm

Gli apparecchi CANTHARELLUS possono essere installati mediante uno speciale raccordo anche su qualsiasi palo di mercato di \varnothing 60 mm

ADAPTOR FOR \varnothing 60 mm POLES

CANTHARELLUS can be installed on any type of \varnothing 60 mm pole available on the market by a very simple adaptor.



CANTHARELLUS

Paletti da giardino
Bollards for garden



CANTHARELLUS ø 150 mm

Code + Colour + Tonality

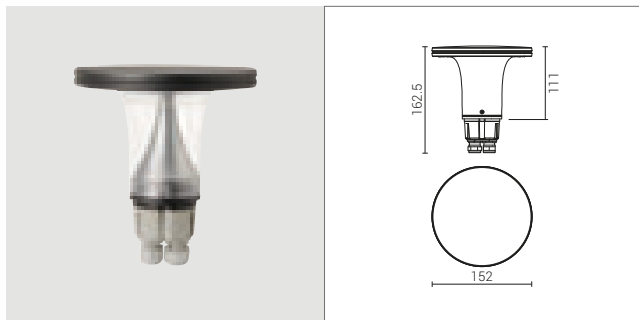

CODE	LAMP	W	lm Nominali-Real output	GR	GM
NEW 5521*	Led	10	1000 600		

IP 65 / Classe I / IK 10
CRI 85 / Driver IN
230V / 50 Hz
CE
Tonalità 3000K o 4000K. Aggiungere 3K o 4K al codice dopo il colore.

IP 65 / Class I / IK 10
CRI 85 / Driver IN
230V / 50 Hz
CE
Color temperature available 3000K or 4000K. Add 3K or 4K to the code after the color.

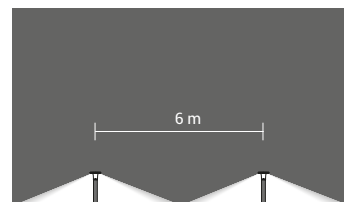

Distanza consigliata con palo h 375 mm.
Recommended distance with a 375 mm post.

CANTHARELLUS ø 200 mm

Code + Colour + Tonality

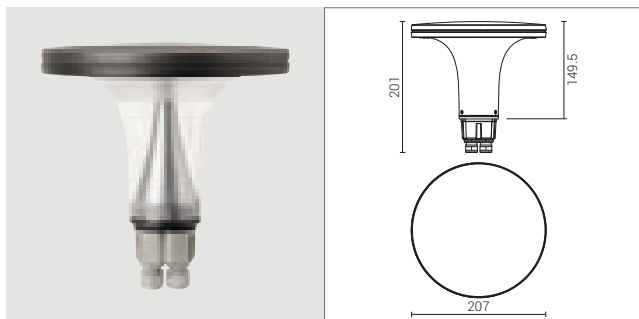

CODE	LAMP	W	lm Nominali-Real output	GR	GM
NEW 5522*	Led	20	2000 1300		

IP 65 / Classe I / IK 10
CRI 85 / Driver IN
230V / 50 Hz
CE
Tonalità 3000K o 4000K. Aggiungere 3K o 4K al codice dopo il colore.

IP 65 / Class I / IK 10
CRI 85 / Driver IN
230V / 50 Hz
CE
Color temperature available 3000K or 4000K. Add 3K or 4K to the code after the color.

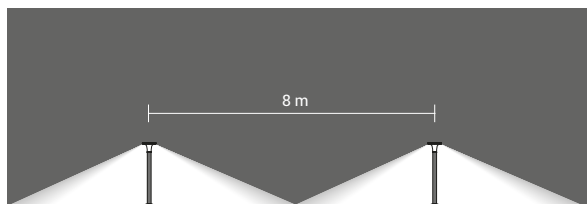

Distanza consigliata con palo h 800 mm.
Recommended distance with a 800 mm post.

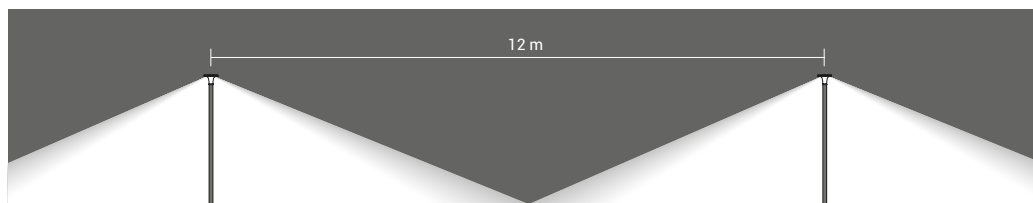

Distanza consigliata con palo h 1875 mm. | Recommended distance with a 1875 mm post

CANTHARELLUS

PALI IN ALLUMINIO | ALUMINIUM POSTS

Code + Colour

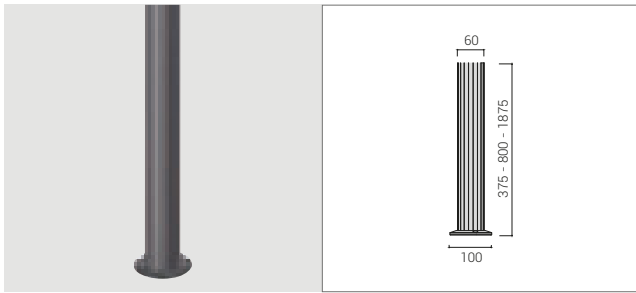

CODE DESCRIZIONE / DESCRIPTION

GR GM

3501* Palo in alluminio / Aluminium post 375 mm

3502* Palo in alluminio / Aluminium post 800 mm

3503* Palo in alluminio / Aluminium post 1875 mm

Struttura in alluminio estruso.
Piede in alluminio forgiato.
Solo palo, apparecchio Cantharellus fornito a parte.

Extruded aluminium structure.
Forged aluminium base.
Post alone. Cantharellus fitting supplied separately.

PICCHETTO | SPIKE

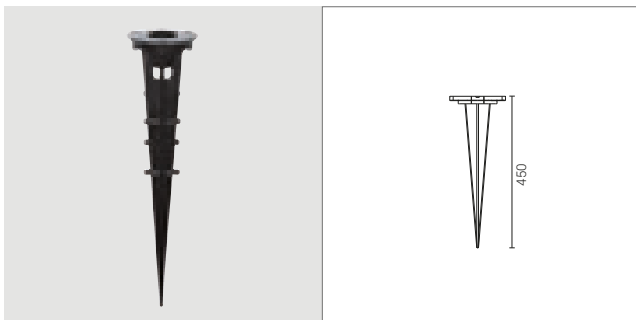

CODE DESCRIZIONE / DESCRIPTION

5505 Picchetto / Spike

Struttura in tecnopolimero.
Listelli laterali di bloccaggio incorporati.
Idonea per cod. 5521 + 3501.

Technopolymer structure.
Small blocking bars incorporated.
Suitable for code 5521 + 3501.

PIASTRA CON TIRAFONDI | PLATE WITH ANCHORING SET



CODE DESCRIZIONE / DESCRIPTION

5519 Piastra con tirafondi / Plate with anchoring set

Piastra inox con tirafondi.
Idonea per cod. 5521-5522 + 3501-3502-3503.

Stainless steel plate with anchoring set.
Suitable for code 5521-5522 + 3501-3502-3503.

RACCORDO PER PALI STANDARD Ø60 | ADAPTOR FOR STANDARD Ø60 POSTS

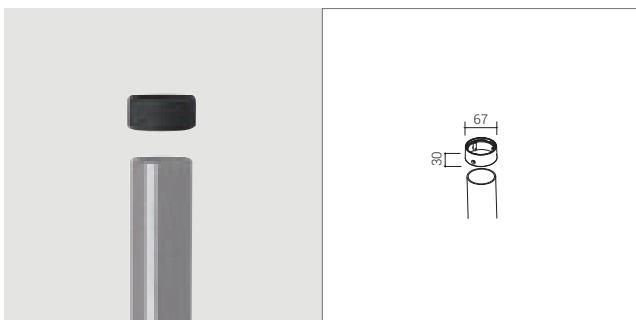

CODE DESCRIZIONE / DESCRIPTION

5506 Raccordo per pali ø 60 / Adaptor for ø60 posts

Alluminio pressofuso primario.
Adattabile a qualsiasi palo ø 60 mm.

Primary die-cast aluminium.
Can be fitted to any ø 60 mm post.



I-LUX

Paletti da giardino
Bollards for garden



Alluminio
Aluminium



Inox Aisi 316L
*Aisi 316L
Stainless Steel*





I-LUX

Paletti da giardino
Bollards for garden

CARATTERISTICHE GENERALI

- Apparecchio da esterno di forma cilindrica per installazione su palo o a parete.
- **Struttura:** coppa in policarbonato trasparente o opale stabilizzato anti UV. Frangiluce orientabile per 5502/5504 ed alettato fisso per 5508/5509. Corpo completo di scatola di cablaggio in tecnopolimero autoestinguente con anello di raccordo in alluminio o cromato.
- Doppio ingresso per alimentazione passante.
- **Pali:** in alluminio estruso o inox AISI 316L con piede in alluminio forgiato o inox AISI 316L.
- **Lampada** 11W a risparmio energetico. Driver incorporato.
- **Finitura.** Per alluminio: decappaggio + fosfocromatazione + fondo epossidico + verniciatura con polveri epossidiche stabilizzate anti UV. Per inox: spazzolato e lucidato.
- Costruito in conformità alle norme europee EN 60598-1:2015 **CE**

GENERAL FEATURES

- *Cylindrical shape outdoor fitting for installation on posts or walls.*
- **Structure:** opal or transparent polycarbonate UV resistant stabilised diffuser. Adjustable louvres for 5502/5504 and fixed inclined for 5508/5509. Body complete with self-extinguishing technopolymer wiring box with aluminium or chrome connection ring.
- Double through power entry.
- **Posts:** in extruded aluminium or AISI 316L stainless steel with forged aluminium or AISI 316L stainless steel base.
- 11W energy saving **lamp.** Driver inside.
- **Finish.** For aluminium: pickling + phosphochrome + epoxy basic coating + UV resistant stabilised epoxy powder coating. For stainless steel: brushed and polished.
- Manufactured in compliance with European standards EN 60598-1:2015 **CE**

PALI ALLUMINIO

I pali in alluminio estruso hanno un particolare design a forma di poliedro stondato a 16 lati. Sono completi di base e disponibili in tre differenti altezze. La finitura grafite anti-UV garantisce la completa tenuta nel tempo.

ALUMINIUM POLES

The poles in extruded aluminium show a very personal design with its 16 rounded sizes profile and its compact base. Three lengths are available and can be installed alone or close one to each other. The finish graphite makes I-LUX not invasive and ideal to be installed everywhere in the garden.

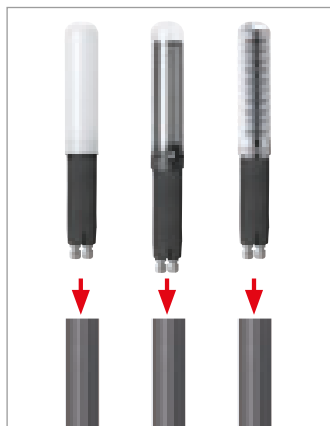

PALI INOX AISI 316L

I pali inox, realizzati in AISI 316L spazzolati e lucidati, sono destinati a resistere nel tempo anche negli ambienti maggiormente esposti a corrosione. La sezione poligonale è un personale design di Goccia ottenuto da trafila.

AISI 316L STAINLESS STEEL POLES

The AISI 316L stainless steel poles are made to resist to the most corrosive even if exclusive environments. The polygonal original profile is maintained and enhances the pole. The finish is brushed and polished. Two lengths are available.

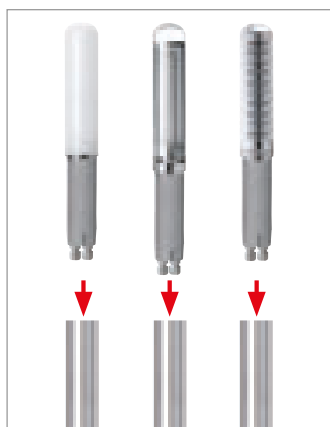

PALI STANDARD Ø 60

Gli apparecchi I-LUX possono essere installati mediante uno speciale raccordo anche su qualsiasi palo Ø 60 reperibile sul mercato.

Ø 60 POLES

I-LUX can be installed on any type of 60 mm diameter pole available on the market by a very simple adaptor.

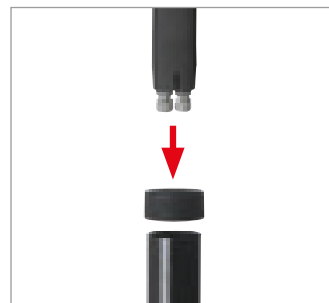

FRANGILUCE ORIENTABILE CON LEVA ESTERNA

Il frangiluce interno è orientabile tramite leva esterna e consente di schermare la luce evitando l'abbagliamento.

ADJUSTABLE ANTI-DAZZLING REFLECTOR

The internal louvre can be adjusted using the outer lever to shield light to prevent glare.

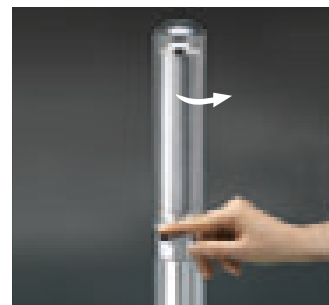

FRANGILUCE ALETTATO

Conforme alle normative in materia di inquinamento luminoso.

INCLINED LOUVERS

Conforms to light pollution directives and guidelines.

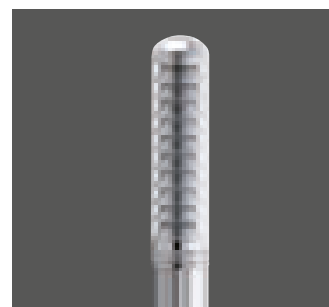

I-LUX

Paletti da giardino
Bollards for garden



EN 60598-1
:2015

EN 60598-2
-1:1989

CORPO LAMPADA ALLUMINIO | ALUMINIUM LIGHT BODY

Code + Colour



CODE LAMP W **GR**

5501* G23 11

Coppa opale.
IP 65 / Classe II / IK 10

Opal diffuser.
IP 65 / Class II / IK 10

Code + Colour

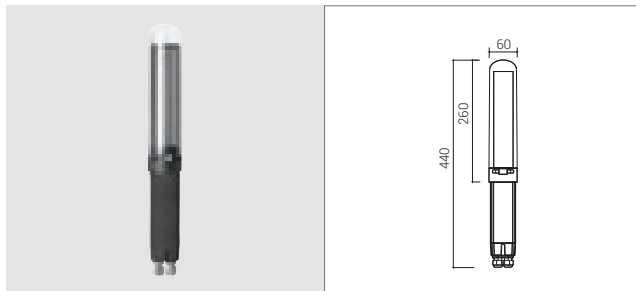

CODE LAMP W **GR**

5502* G23 11

Coppa trasparente e frangiluce orientabile.
IP 65 / Classe II / IK 10

Clear diffuser + antidazzling adjustable
reflector.
IP 65 / Class II / IK 10

Code + Colour

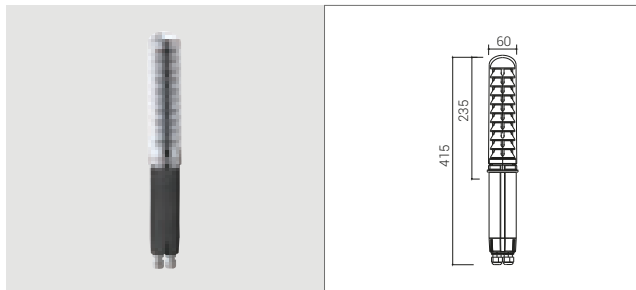

CODE LAMP W **GR**

5508* G23 11

Coppa trasparente e frangiluce alettato.
IP 65 / Classe II / IK 10

Clear diffuser + inclined louvers.
IP 65 / Class II / IK 10

PALI IN ALLUMINIO | ALUMINIUM POLES

Code + Colour

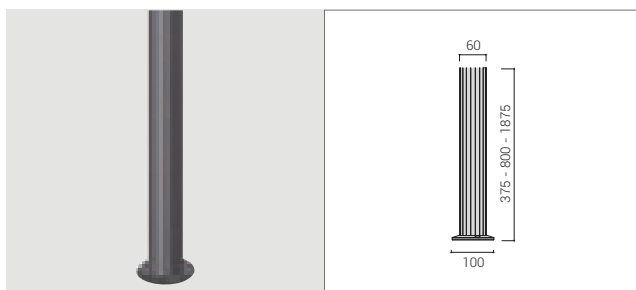

CODE DESCRIZIONE / DESCRIPTION **GR**

3501* Palo in alluminio / Aluminium pole 375 mm

3502* Palo in alluminio / Aluminium pole 800 mm

3503* Palo in alluminio / Aluminium pole 1875 mm

Struttura in alluminio estruso.
Piede in alluminio forgiato.
Solo palo, apparecchio I-Lux fornito a parte.
Classe II

Structure in aluminium extruded.
Base in forged aluminium.
Pole only, I-Lux fitting supplied separately.
Class II

BRACCI IN ALLUMINIO | ALUMINIUM ARMS

Code + Colour

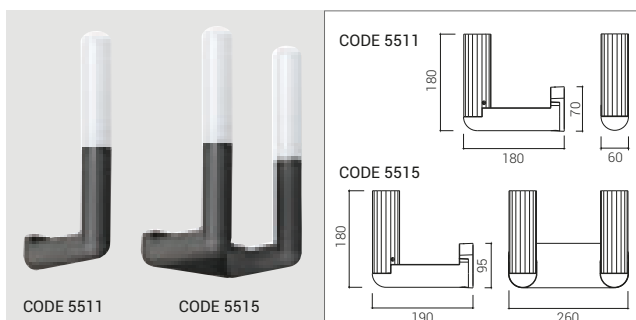

CODE DESCRIZIONE / DESCRIPTION **GR**

5511* Braccio a muro singolo / Single wall-arm

5515* Braccio a muro doppio / Double wall-arm

Solo braccio, apparecchio I-Lux fornito a parte.
Classe II

Arm only, I-Lux fitting supplied separately.
Class II

CODE 5511

CODE 5515



EN 60598-1
:2015

EN 60598-2
-1:1989

CORPO LAMPADA INOX AISI 316L | STAINLESS STEEL AISI 316L LIGHT BODY

Code + Colour

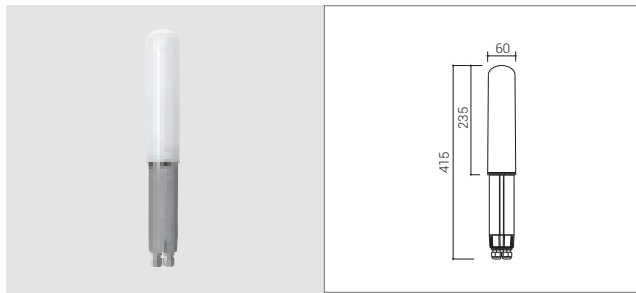

CODE LAMP W **IN**

5503* G23 11

Coppa opale.
Anellino di raccordo finitura inox.
IP 65 / Classe II / IK 10
CE

Opal diffuser.
Connection ring stainless steel finished.
IP 65 / Class II / IK 10
CE

Code + Colour

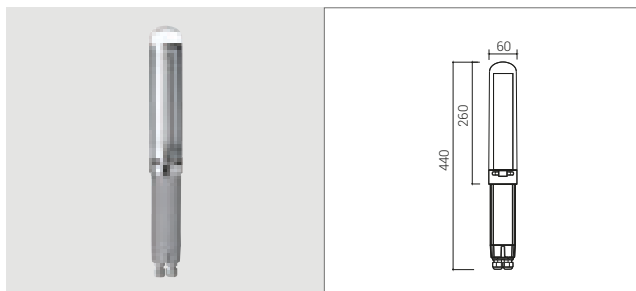

CODE LAMP W **IN**

5504* G23 11

Coppa trasparente e frangiluce orientabile.
Anellino di raccordo finitura inox.
IP 65 / Classe II / IK 10
CE

Clear diffuser + antidazzling adjustable reflector.
Connection ring stainless steel finished.
IP 65 / Class II / IK 10
CE

Code + Colour

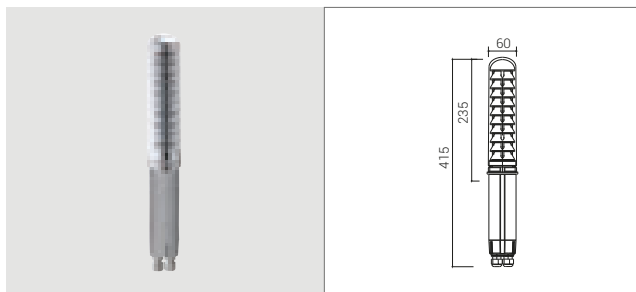

CODE LAMP W **IN**

5509* G23 11

Coppa trasparente e frangiluce alettato.
Anellino di raccordo finitura inox.
IP 65 / Classe II / IK 10
CE

Clear diffuser + inclined louvers.
Connection ring stainless steel finished.
IP 65 / Class II / IK 10
CE

PALI INOX AISI 316L | STAINLESS STEEL AISI 316L POST

Code + Colour

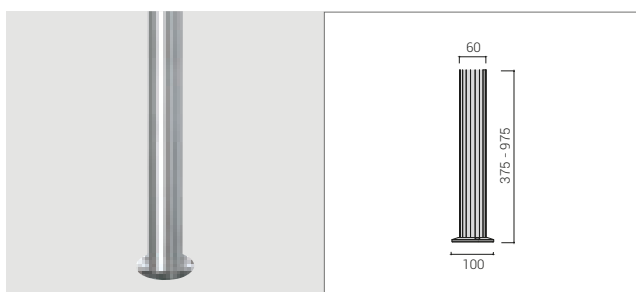

CODE DESCRIZIONE / DESCRIPTION **IN**

3511* Palo inox AISI 316L / AISI 316L stainless steel pole 375 mm

3512* Palo inox AISI 316L / AISI 316L stainless steel pole 975 mm

Struttura in inox AISI 316L . Piede in inox AISI 316L. Interamente spazzolato e lucidato.
Solo palo, apparecchio I-Lux fornito a parte.
Classe II

Structure in AISI 316L Stainless Steel.
Base in AISI 316L Stainless Steel.
Brushed and polished.
Pole only, I-Lux fitting supplied separately.
Class II

BRACCI INOX AISI 316L | STAINLESS STEEL AISI 316L ARMS

Code + Colour

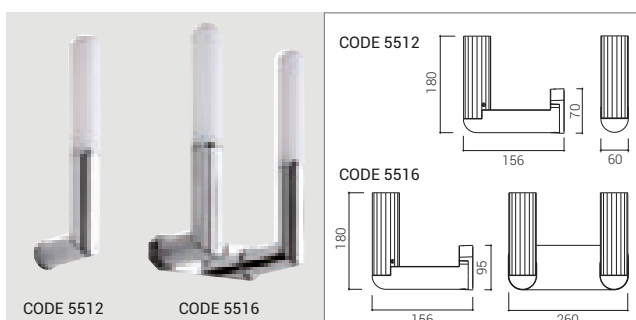

CODE DESCRIZIONE / DESCRIPTION **IN**

5512* Braccio a muro singolo / Single wall-arm

5516* Braccio a muro doppio / Double wall-arm

Struttura in alluminio primario lucidato e spazzolato.
Finitura INOX.
Solo braccio, apparecchio I-Lux fornito a parte.
Classe II

Primary aluminium housing, corrosion-resistant.
Stainless steel finish.
Arm only, I-Lux fitting supplied separately.
Class II



I-LUX

Paletti da giardino
Bollards for garden

PICCHETTO | SPIKE

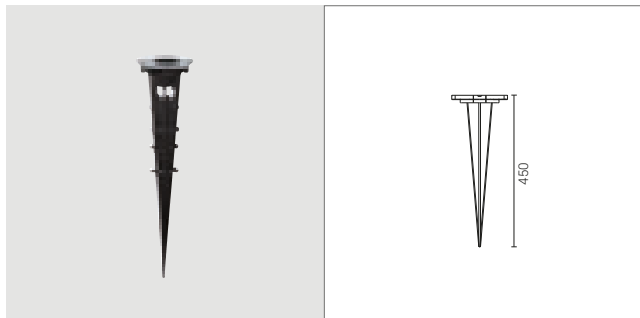

CODE DESCRIZIONE / DESCRIPTION

5505 Picchetto / Spike

Struttura in tecnopolimero.
Listelli laterali di bloccaggio incorporati.

*Technopolymer body.
Small blocking bars incorporated.*

PIASTRA CON TIRAFONDI | PLATE WITH ANCHORING SET



CODE DESCRIZIONE / DESCRIPTION

5519 Piastra con tirafondi / Plate with anchoring set

Piastra inox con tirafondi.
Idonea per cod. 3501-3502-3503-3511-3512.

*Stainless steel plate with anchoring set.
Suitable for code 3501-3502-3503-3511-3512.*

RACCORDO PER PALI STANDARD Ø60 | ADAPTOR FOR STANDARD POLES Ø60



CODE DESCRIZIONE / DESCRIPTION

5507 Raccordo per pali ø 60 / Adaptor for 60 mm diameter pole

Alluminio pressofuso primario.
Adattabile a qualsiasi palo ø 60 mm.

*Primary aluminium.
To be installed on any pole 60 mm diameter.*



I-MAGO

Paletti da giardino
Bollards for garden

Brevetto depositato
Registered patent

Alluminio
Aluminium
LED



Inox AISI 316L
AISI 316L Stainless Steel
LED

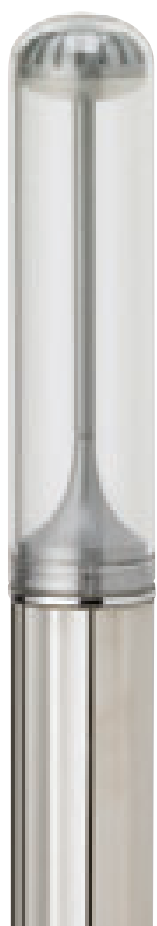



I-MAGO

Paletti da giardino
Bollards for garden

CARATTERISTICHE GENERALI

- Apparecchio da giardino di forma cilindrica per installazione su palo.
- **Struttura:** coppa in policarbonato trasparente stabilizzato anti UV. Corpo completo di scatola di cablaggio in tecnopolimero autoestinguente con anello di raccordo in alluminio verniciato o cromato.
- Doppio ingresso per alimentazione passante.
- **Circuito di 4 Led 7,5W totali** di nuova generazione inserito in testa e rivolto verso il basso. Vita garantita 60.000 h con successivo scadimento max del 20%. Driver incorporato.
- Pali in alluminio estruso o inox AISI 316L con piede in alluminio forgiato o inox AISI 316L.
- **Finitura.** Per alluminio: decappaggio + fosfocromatazione + fondo epossidico + verniciatura con polveri epossidiche stabilizzate anti UV. Per inox: spazzolato e lucidato.
- Costruito in conformità alle norme europee EN 60598-1:2015 **CE**

GENERAL FEATURES

- *Cylindrical shape garden fitting for installation on posts.*
- **Structure:** transparent polycarbonate UV resistant stabilised diffuser. Body complete with self-extinguishing technopolymer wiring box with painted aluminium or chrome connection ring.
- *Double through power entry.*
- **New generation 4 LED 7.5W total circuit** inserted in the head and turned downward. Minimum life 60,000 h with subsequent deterioration max 20%. Driver inside.
- *Posts in extruded aluminium or AISI 316L stainless steel with forged aluminium or AISI 316L stainless steel base.*
- **Finish.** For aluminium: pickling + phosphochrome + epoxy basic coating + UV resistant stabilised epoxy powder coating. For stainless steel: brushed and polished.
- *Manufactured in compliance with European standards EN 60598-1:2015 **CE***

CORPO LAMPADA

- 1 - Unità LED 7,5W / 750 lumen
- 2 - Coppetta diffondente
- 3 - Cupolina in alluminio lucido
- 4 - Coppa trasparente
- 5 - Alluminio anodizzato
- 6 - Anello in Alluminio/cromato
- 7 - Driver 230V

LIGHT BODY

- 1 - Led unit 7,5W / 750 lumen
- 2 - Opal diffuser
- 3 - Round thermal heat sink
- 4 - Clear diffuser
- 5 - Anodized Aluminium
- 6 - Holding ring
- 7 - 220-250 V 50-60 Hz driver

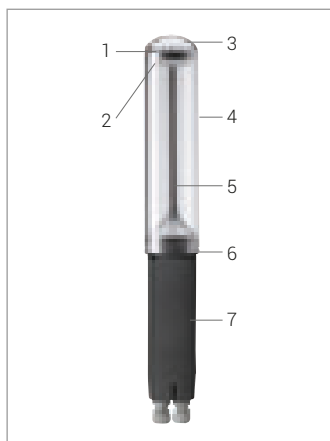

UNA PICCOLA CASCATA DI LUCE

La luce dei 4 Led di potenza è orientata con un angolo di diffusione di 120° verso il basso.

A SMALL WATERFALL OF LIGHT

The light from the 4 power LEDs is directed with an angle of diffusion of 120° downward.

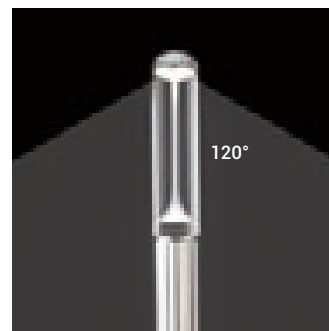

IRRAGGIAMENTO

LIGHT DISTRIBUTION

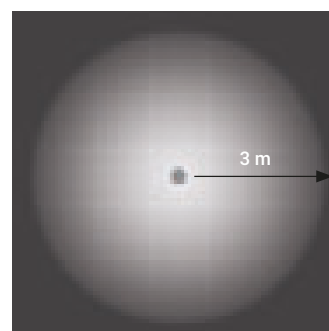

PALI

Il corpo lampada è installabile negli appositi pali scanalati in alluminio verniciato o inox AISI 316L, disponibili in due altezze diverse.

POLES

I-Mago can be installed on the Goccia rounded size poles in aluminium or AISI 316L stainless steel or on the standard 60 mm diameter pole by the adaptor.

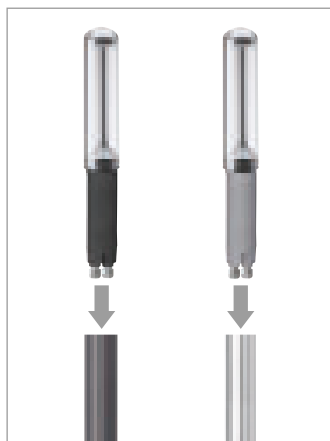

DISTANZA CONSIGLIATA CON PALO H 375 mm

SPACING SUGGESTED WITH H 375 mm POLE

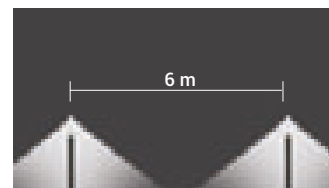

I-MAGO

Paletti da giardino
Bollards for garden



CORPO LAMPADA ALLUMINIO | ALUMINIUM LIGHT BODY

Code + Colour + Tonality

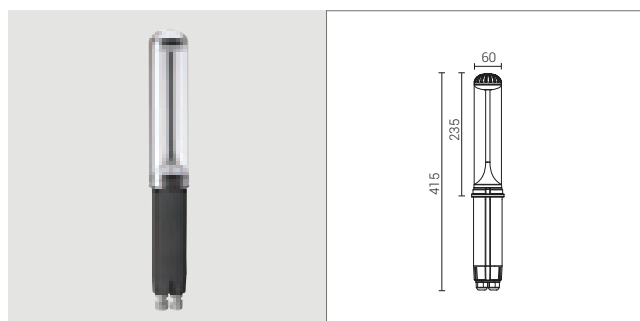

CODE	LAMP	W	lm	Nominali-Real output	GR
------	------	---	----	----------------------	----

5510*	Led	7,5	750	380	
--------------	-----	-----	-----	-----	--

Diffusore in policarbonato trasparente.
Parti interne in alluminio satinato.
Gruppo di 4 Led - 7,5 W totali
IP 65 / Classe II / IK 10
CRI 85 / Driver IN / 500 mA
230V / 50 Hz
CE
Tonalità 3000K o 4000K. Aggiungere 3K o 4K al codice dopo il colore.

Clear polycarbonate diffuser.
Inside of anodized aluminium.
4 leds unit - 7,5W 750 lumen totally
IP 65 / Class II / IK 10
CRI 85 / Driver IN / 500 mA
220-250V / 50-60 Hz
CE
Color temperature available 3000K or 4000K. Add 3K or 4K to the code after the color.

PALI IN ALLUMINIO | ALUMINIUM POLES

Code + Colour

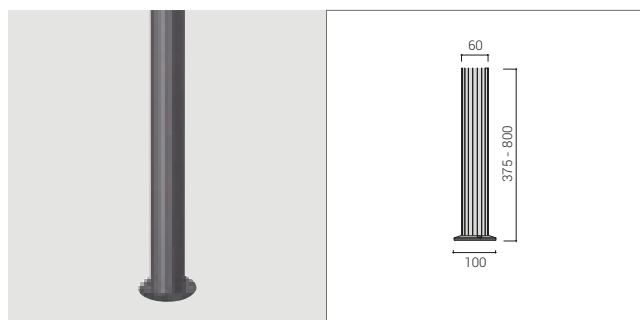

CODE	DESCRIZIONE / DESCRIPTION	GR
------	---------------------------	----

3501*	Palo in alluminio / Aluminium pole 375 mm	
--------------	---	--

3502*	Palo in alluminio / Aluminium pole 800 mm	
--------------	---	--

Struttura in alluminio estruso.
Piede in alluminio forgiato.
Solo palo, apparecchio I-Mago fornito a parte.
Classe II

Structure in aluminium extruded.
Base in forged aluminium.
Pole only, I-Mago fitting supplied separately.
Class II

CORPO LAMPADA INOX AISI 316L | STAINLESS STEEL AISI 316L LIGHT BODY

Code + Colour + Tonality

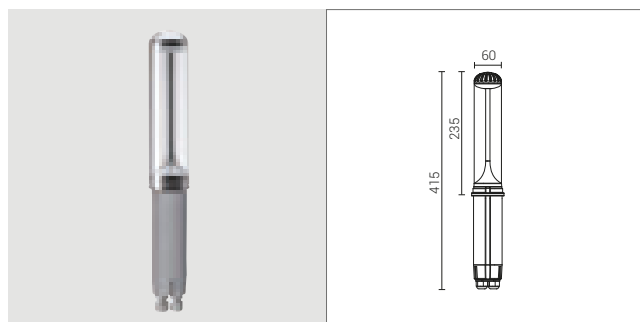

CODE	LAMP	W	lm	Nominali-Real output	IN
------	------	---	----	----------------------	----

5500*	Led	7,5	750	380	
--------------	-----	-----	-----	-----	--

Diffusore in policarbonato trasparente.
Parti interne in alluminio satinato.
Gruppo di 4 Led - 7,5 W totali
IP 65 / Classe II / IK 10
CRI 85 / Driver IN / 500 mA
230V / 50 Hz
CE
Tonalità 3000K o 4000K. Aggiungere 3K o 4K al codice dopo il colore.

Clear polycarbonate diffuser.
Inside of anodized aluminium.
4 leds unit - 7,5W 750 lumen totally
IP 65 / Class II / IK 10
CRI 85 / Driver IN / 500 mA
220-250V / 50-60 Hz
CE
Color temperature available 3000K or 4000K. Add 3K or 4K to the code after the color.

PALI INOX AISI 316L | STAINLESS STEEL AISI 316L POSTS

Code + Colour

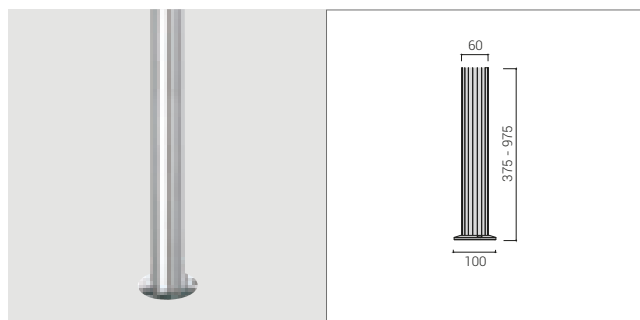

CODE	DESCRIZIONE / DESCRIPTION	IN
------	---------------------------	----

3511*	Palo inox AISI 316L / AISI 316L stainless steel pole 375 mm	
--------------	---	--

3512*	Palo inox AISI 316L / AISI 316L stainless steel pole 975 mm	
--------------	---	--

Struttura in inox AISI 316L. Piede in inox AISI 316L. Interamente spazzolato e lucidato.
Solo palo, apparecchio I-Mago fornito a parte.
Classe II

Structure in AISI 316L Stainless Steel. Base in AISI 316L Stainless Steel. Brushed and polished.
Pole only, I-Mago fitting supplied separately.
Class II

PICCHETTO | SPIKE

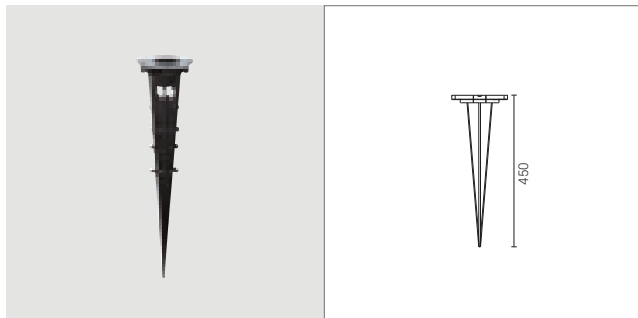

CODE DESCRIZIONE / DESCRIPTION

5505 Picchetto / Spike

Struttura in tecnopolimero.
Listelli laterali di bloccaggio incorporati.

*Technopolymer body.
Small blocking bars incorporated.*

PIASTRA CON TIRAFONDI | PLATE WITH ANCHORING SET



CODE DESCRIZIONE / DESCRIPTION

5519 Piastra con tirafondi / Plate with anchoring set

Piastra inox con tirafondi.
Idonea per cod. 3501-3502-3511-3512.

*Stainless steel plate with anchoring set.
Suitable for code 3501-3502-3511-3512.*

RACCORDO PER PALI STANDARD Ø60 | ADAPTOR FOR STANDARD POLES Ø60

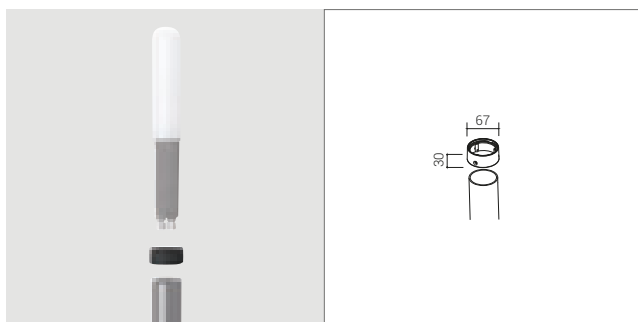

CODE DESCRIZIONE / DESCRIPTION

5507 Raccordo per pali ø 60 / Adaptor for 60 mm diameter pole

Alluminio pressofuso primario.
Adattabile a qualsiasi palo ø 60 mm.

*Primary aluminium.
To be installed on any pole 60 mm diameter.*



I-DEA

Paletti da giardino
Bollards for garden

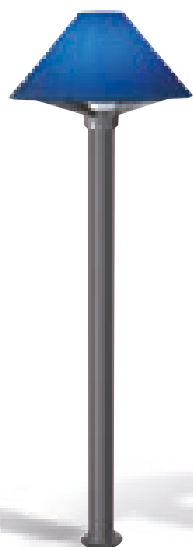

I-Dea
LED



Blu Pastello
Pastel Blue



Bianco Opale
Opal White



Arancio Brillante
Brilliant Orange



Verde Prato
Lawn Green

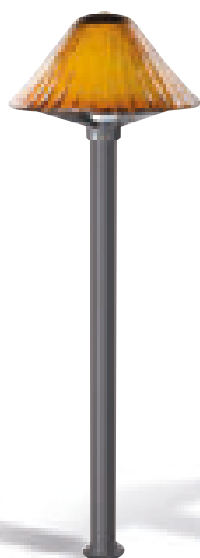

I-Dea Preziosa
LED



Ambra
Amber



Blu Zirconio
Zircon Blue



Verde Smeraldo
Emerald Green



I-DEA

Paletti da giardino
Bollards for garden

CARATTERISTICHE GENERALI

- Apparecchio da giardino per installazione su palo.
- **Struttura:** paraluce in policarbonato o vetro lavorato a mano. Interno del paraluce bianco per la massima riflessione della luce verso il basso. Raggiera in alluminio pressofuso.
- Completo di scatola di cablaggio in tecnopolimero autoestinguente.
- **Palo** in alluminio estruso. Piede in alluminio forgiato.
- Doppio ingresso per alimentazione passante.
- **Lampada** 14W a risparmio energetico o **Led di nuova generazione.** Il Led proietta la luce verso l'alto che viene riflessa verso il basso dall'interno bianco della coppa. Vita garantita 60.000 h con successivo scadimento max del 20%. Driver incorporato.
- **Finitura:** su alluminio, decappaggio + fosfocromatazione + fondo epossidico + verniciatura con polveri epossidiche stabilizzate anti UV.
- Costruito in conformità alle norme europee EN 60598-1:2015 **CE**

GENERAL FEATURES

- Garden fitting for installation on posts.
- **Structure:** polycarbonate or hand-crafted glass lampshade. The inside of the lampshade is white for maximum downward light reflection. Aluminium die-cast spokes.
- Complete with self-extinguishing technopolymer wiring box.
- **Post** in extruded aluminium. Forged aluminium base.
- Double through power entry.
- 14W energy saving lamp or new generation LED lamp. The LED projects light upward, which is reflected downward from inside the white of the diffuser. Minimum life 60,000 h with subsequent deterioration max 20%. Driver inside.
- **Finish:** on aluminium, pickling + phosphochrome + epoxy basic coating + UV resistant stabilised epoxy powder coating.
- Manufactured in compliance with European standards EN 60598-1:2015 **CE**

I-DEA LED

- 1 - Paraluce in policarbonato colorato con interno riflettente per irraggiare la luce verso il basso
- 2 - Unità Led
- 3 - Dissipatore di calore e riflettore luminoso

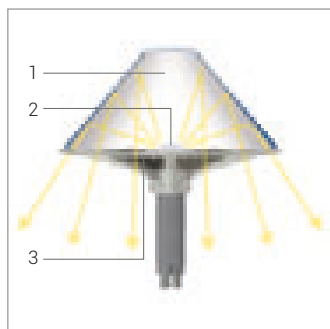

I-DEA LED

- 1 - Coloured polycarbonate lampshade with reflective inside to radiate light downward
- 2 - LED unit
- 3 - Heat sink and light reflector

PARALUCE COLORATI

I paraluce in policarbonato sono disponibili in 4 colori. Quelli in vetro lavorato a mano in 3 colori.

COLOURED LAMPSHADES

Polycarbonate lampshades come in 4 different colours. Hand-crafted glass lampshades come in 3 different colours.



I-DEA

- 1 - Paraluce in policarbonato colorato
- 2 - Corpo lampada con raggiera portante in alluminio.



I-DEA

- 1 - A coloured polycarbonate lampshade
- 2 - Lamp housing with aluminium spokes.

IRRAGGIAMENTO

LIGHT DISTRIBUTION

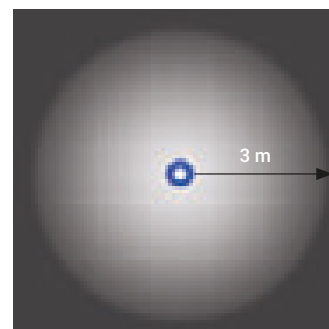

I-DEA PREZIOSA

- 1 - Paraluce in vetro lavorato.
- 2 - Sottocoppa in policarbonato bianco.
- 3 - Corpo lampada con raggiera portante in alluminio.



I-DEA PREZIOSA

- 1 - Lampshade. Crafted glass.
- 2 - Interior lampshade in white polycarbonate.
- 3 - Lamp housing with aluminium spokes.

DISTANZA CONSIGLIATA CON PALO
H 800 mm

SPACING SUGGESTED WITH
H 800 mm POLE

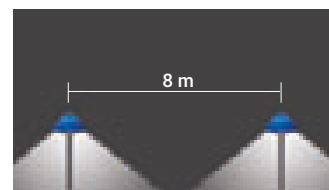

I-DEA

Paletti da giardino
Bollards for garden



PARALUCE I-DEA | I-DEA LAMPSHADE

Code + Colour

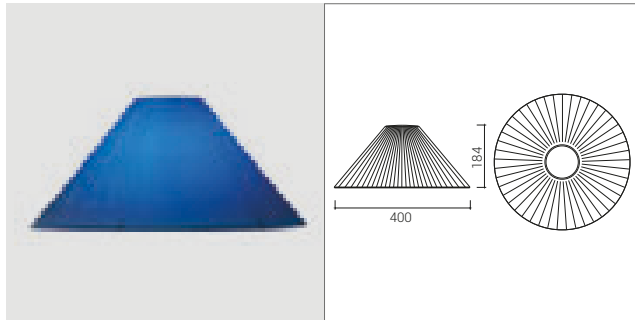

CODE DESCRIZIONE / DESCRIPTION



5531* Paraluce / Lampshade

Paraluce in policarbonato stampato in pasta.
Resistente al degrado da raggi UV.
Speciale rigatura interna frangiluce.
C€

*Die cast paste polycarbonate lampshade.
Resistant to UV degeneration.
Special internal light-diffusion grooving.
C€*

PARALUCE I-DEA PREZIOSA | I-DEA PREZIOSA LAMPSHADE

Code + Colour

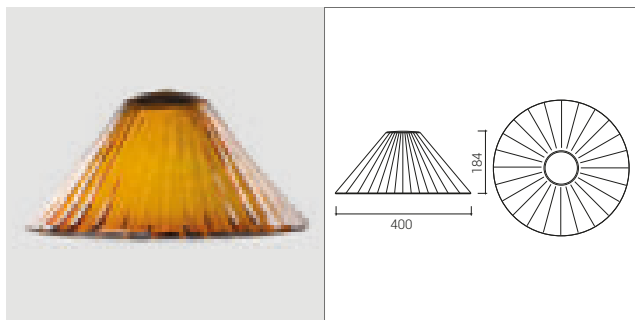

CODE DESCRIZIONE / DESCRIPTION



5534* Paraluce in vetro / Glass lampshade

Paraluce in vetro lavorato con paraluce interno in policarbonato bianco.
Installabile sul gruppo lampada cod. 5536 - 5537.
C€

*Crafted glass lampshade with interior lampshade in white polycarbonate.
Available to mount on lamp series cod. 5536 - 5537.
C€*

CORPO LAMPADA LED | LED LIGHT BODY

Code + Colour + Tonality

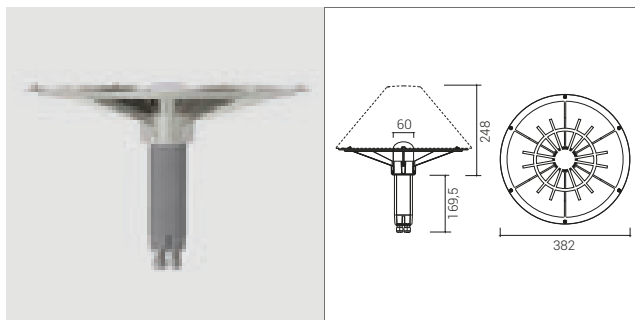

CODE LAMP W Im Nominali-Real output



5537* Led 14 1420 747

Coppa di protezione in policarbonato trasparente. Installabile su pali I-Dea o I-Lux o qualsiasi palo ø60 mm.
IP 65 / Classe II
CRI 85 / Driver IN
230V / 50 Hz
C€

Tonalità 3000K o 4000K. Aggiungere 3K o 4K al codice dopo il colore.

*Clear polycarbonate diffuser.
To be installed on I-Dea/I-Lux poles or on any pole 60 mm diameter.
IP 65 / Class II
CRI 85 / Driver IN
230V / 50 Hz
C€
Color temperature available 3000K or 4000K. Add 3K or 4K to the code after the color.*

CORPO LAMPADA E27 | E27 LIGHT BODY

Code + Colour

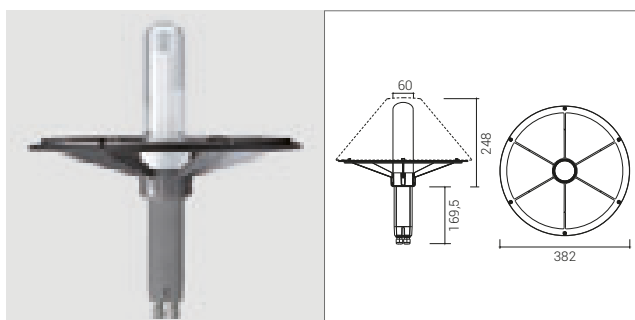

CODE LAMP W



5536* E 27 18-23-33

Coppa di protezione in policarbonato trasparente. Installabile su pali I-Dea o I-Lux o qualsiasi palo ø60 mm.
IP 65 / Classe II
C€

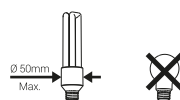

*Clear polycarbonate diffuser.
To be installed on I-Dea/I-Lux poles or on any pole 60 mm diameter.
IP 65 / Class II
C€*

I-DEA

PALI IN ALLUMINIO | ALUMINIUM POLES

Code + Colour

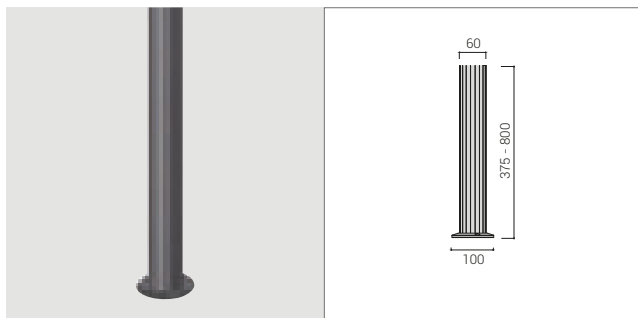

CODE DESCRIZIONE / DESCRIPTION

GR

3501* Palo in alluminio / Aluminium pole 375 mm

3502* Palo in alluminio / Aluminium pole 800 mm

Struttura in alluminio estruso.
Piede in alluminio forgiato.
Solo palo, apparecchio I-Dea fornito a parte.
Classe II ☐

Structure in aluminium extruded.
Base in forged aluminium.
Pole only, I-Dea fitting supplied separately.
Class II ☐

PICCHETTO | SPIKE

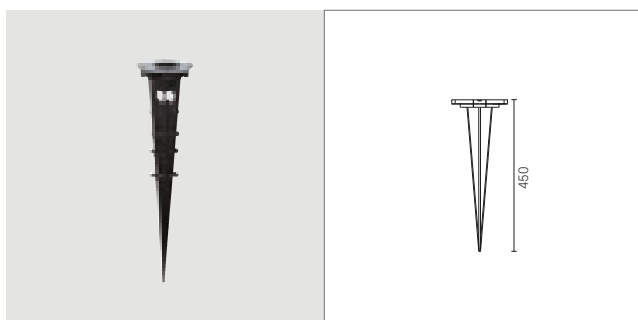

CODE DESCRIZIONE / DESCRIPTION

5505 Picchetto / Spike

Struttura in tecnopolimero.
Listelli laterali di bloccaggio incorporati.

Technopolymer body.
Small blocking bars incorporated.

PIASTRA CON TIRAFONDI | PLATE WITH ANCHORING SET



CODE DESCRIZIONE / DESCRIPTION

5519 Piastra con tirafondi / Plate with anchoring set

Piastra inox con tirafondi.
Idonea per cod. 3501-3502.

Stainless steel plate with anchoring set.
Suitable for code 3501-3502.



SERVER POINT

TORRETTE MULTIFUNZIONE
GARDEN POWER POINTS



Distribuire la luce, coordinare comodamente energia, accessi, antifurto e tutti i comandi di domotica da un unico punto. Oggi si può, con SERVER POINT, la nuova torretta di distribuzione modulare dal design pulito ma curatissimo di Goccia Illuminazione. Disponibile in due altezze, SERVER POINT è attrezzato con 2 prese standard tedesco o industriali CEE 17 e predisposto ad accogliere da 4 a 12 moduli opzionali della serie Living International, Light e Light Tech di BTicino, a cui è possibile aggiungere un utile faretto segnalibro o il rilevatore di presenza.



To easily coordinate your power supply, gate controls, security systems and home automation in general, Goccia Illuminazione has created SERVER POINT, the new control and energy distribution column. Available in two heights, SERVER POINT is equipped with two German standard sockets or industrial CEE 17 and is designed to house from 4 to 12 additional units of the Living International, Light and Light Tech series by BTicino, to which one may also add a handy Goccia Illuminazione watertight LED path marker or the pir sensor.



SERVER POINT

Torrette multifunzione
Garden power points

CARATTERISTICHE GENERALI

- Torretta di distribuzione da esterno per installazione a terra.
- **Struttura:** alluminio estruso con piede e testa in pressofusione.
- Due o quattro sportelli per lato contenenti due prese standard tedesco della serie Living International, Light e Light Tech di BTicino, oppure due prese industriali CEE 17. Gli sportelli liberi possono essere utilizzati per inserire altri frutti di servizio della serie Living International (interruttori/ deviatori/pulsanti/interruttori automatici).
- Vano, coperto da sportello, per l'inserimento di un faretto da 1W (optional).
- Possibilità di installare, in apposito vano, il rilevatore di presenza Goccia cod. 5308 (optional).
- Doppia scatola per separare il cablaggio dei comandi luce dall'energia.
- **Finitura:** su alluminio, decappaggio + fosfocromatazione + fondo epossidico + verniciatura con polveri epossidiche stabilizzate anti UV.
- Costruito in conformità alle norme europee EN 61439-1:2011 **CE**

GENERAL FEATURES

- *Outdoor energy distribution column for ground installation.*
- **Structure:** extruded aluminium with die-cast base and head.
- *Two or four panels per side, containing two German standard power sockets of the Living International, Light and Light Tech series equipment by BTicino, or two industrial CEE 17 sockets. The free panels can be used to insert other Living International series service products (switches/diverters/buttons/automatic switches).*
- *Panel-covered space for insertion of a 1W light (optional).*
- *Option of installing a Goccia Pir sensor, code 5308 (optional), in a special space.*
- *Dual box to separate lighting control wiring from energy wiring.*
- **Finish:** on aluminium, pickling + phosphochrome + epoxy basic coating + UV resistant stabilised epoxy powder coating.
- *Manufactured in compliance with European standards EN 61439-1:2011 **CE***

SERVER POINT, LA TORRETTA POLIFUNZIONALE

Può, concretamente, svolgere tutte le funzioni offerte dagli apparecchi serie Living International, Light e Light Tech di BTicino.

SERVER POINT, THE MULTI-FUNCTIONAL COLUMN

In practice, it can effectively perform all the services offered by the Living International, Light and Light Tech series equipment by BTicino.

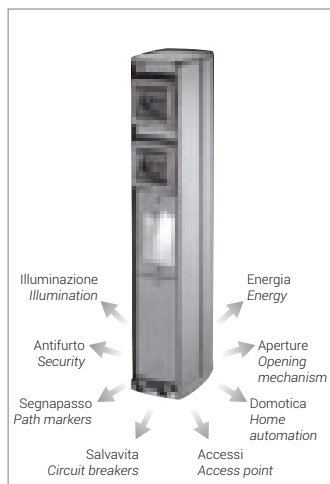

LE DOTAZIONI MODULARI

Server Point 1: 4 sportelli, 8 moduli.
Server Point 2: 8 sportelli, 16 moduli.
È possibile aggiungere un utile faretto segnapasso a tenuta stagna Goccia Illuminazione a Led.

MODULAR EQUIPMENT

Server Point 1: 4 panels, 8 modules.
Server Point 2: 8 panels, 16 modules.
A handy Goccia Illuminazione watertight LED path marker can also be added.

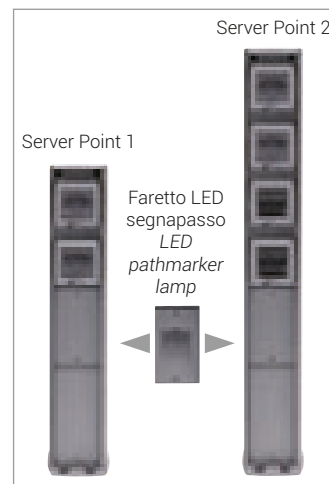

DOPPI INGRESSI SU DUE LATI

DOUBLE ENTRIES ON TWO SIDES

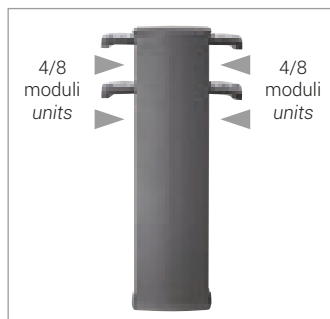

RILEVATORE DI PRESENZA

Se una persona o un veicolo entrano nel campo del sensore, viene comandata automaticamente l'accensione del faretto led del Server Point o una qualunque altra utenza domestica: lampade da giardino, cancello elettrico, porte automatiche ecc. Sono possibili tre regolazioni: luminosità crepuscolare per regolare l'orario di funzionamento, area di rilevamento, temporizzazione dell'accensione.



DOTAZIONE PRESE

Fornito con due prese standard Tedesco della serie Living International, Light e Light Tech di BTicino, oppure due prese industriali CEE 17.

SOCKETS SUPPLIED

Equipped with two German standard sockets from the Living International, Light and Light Tech series by BTicino, or two industrial CEE 17 sockets.



PIR SENSOR

When somebody enters in the area is detected by the pir sensor, the switch comes on to introduce a new function: light to the led in the same pole or to the house lights or what else. Three regulations are available: detection area, switching timing and daylight to regulate the working beginning.

SERVER POINT

Torrette multifunzione
Garden power points



EN 61439-1
:2011

SERVER POINT 1

Code + Colour

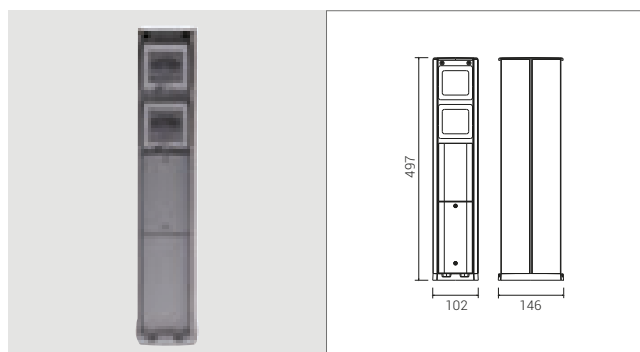

CODE DESCRIZIONE / DESCRIPTION

GR

5301* Struttura - 2 prese standard tedesco - 8 moduli
Structure - 2 German standard power sockets+2 empty panels

Due sportelli a molla contenenti due prese standard Tedesco della serie Living International, Light e Light Tech di BTicino. Due sportelli a molla aggiuntivi BTicino per altri quattro moduli aggiuntivi. Vano per apparecchio led Goccia Illuminazione opzionale. Due cassette di derivazione complete di morsettiera.

IP 55 ⚡ ⚡ ⚡

CE

Two spring-loaded panels containing two German standard sockets from the Living International, Light and Light Tech series by BTicino.

Two additional BTicino spring-loaded panels for four additional units.

Space for optional LED lighting unit by Goccia Illuminazione.

Two switching boxes complete with terminal board.

IP 55 ⚡ ⚡ ⚡

CE

SERVER POINT 1 - CEE 17

Code + Colour

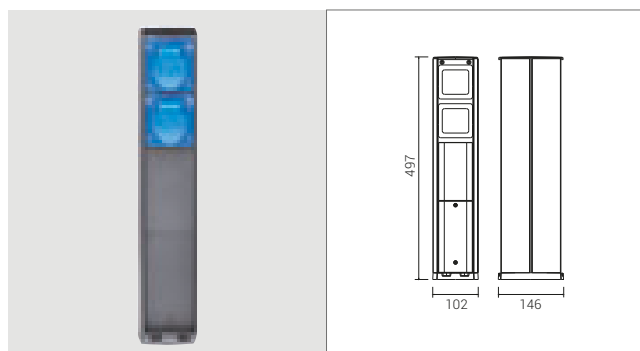

CODE DESCRIZIONE / DESCRIPTION

GR

5303* Struttura - 2 prese CEE 17 16A
Structure - 2 CEE 17 16A sockets

Due sportelli a molla contenenti due prese industriali CEE 17 della serie Living International, Light e Light Tech di BTicino. Due sportelli a molla aggiuntivi BTicino per altri quattro moduli aggiuntivi. Vano per apparecchio led Goccia Illuminazione opzionale. Due cassette di derivazione complete di morsettiera.

IP 55 ⚡ ⚡ ⚡

CE

Two spring-loaded panels containing two industrial CEE 17 sockets from the Living International, Light and Light Tech series by BTicino.

Two additional BTicino spring-loaded panels for four additional units.

Space for optional LED lighting unit by Goccia Illuminazione.

Two switching boxes complete with terminal board.

IP 55 ⚡ ⚡ ⚡

CE

SERVER POINT 2

Code + Colour

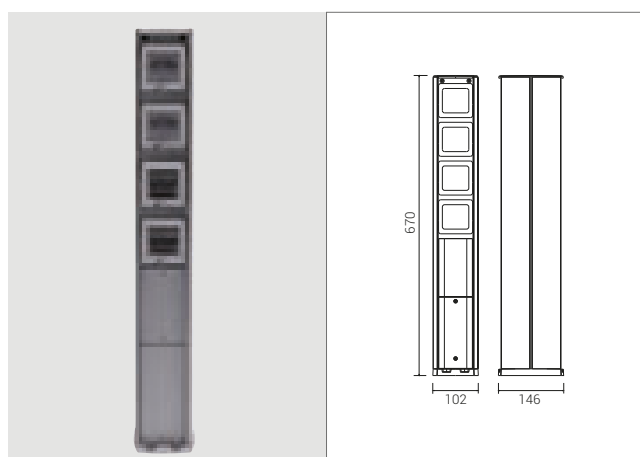

CODE DESCRIZIONE / DESCRIPTION

GR

5302* Struttura - 2 prese standard tedesco - 16 moduli
Structure - 2 German standard power sockets+6 empty panels

Sei sportelli a molla aggiuntivi BTicino per altri dodici moduli aggiuntivi. Prese industriali 230/380 V a richiesta.

IP 55 ⚡ ⚡ ⚡

CE

Six additional BTicino spring-loaded panels for twelve additional units.

Industrial CEE 17 sockets 230V/380 V on request.

IP 55 ⚡ ⚡ ⚡

CE

SERVER POINT

LED SEGNAPASSO | RECESSED LED PATH MARKER

Code + Colour + Tonality

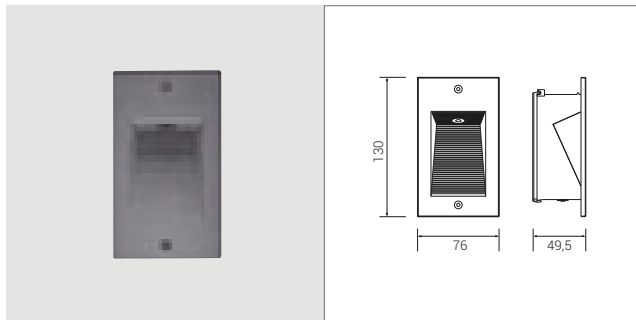

CODE	DESCRIZIONE / DESCRIPTION	W	Im Nominali-Real output	GR
5315*	Led segnapasso ad incasso Recessed LED path marker	1	105 51	

Struttura in policarbonato.
IP 65 / Classe II / IK 10
Driver IN
230V / 50 Hz
CE

Tonalità 3000K o 4000K. Aggiungere 3K o 4K al codice dopo il colore.

Polycarbonate structure.
IP 65 / Class II / IK 10
Driver IN
230V / 50 Hz
CE
Color temperature available 3000K or 4000K. Add 3K or 4K to the code after the color.

RILEVATORE DI PRESENZA | PIR SENSOR

Code + Colour

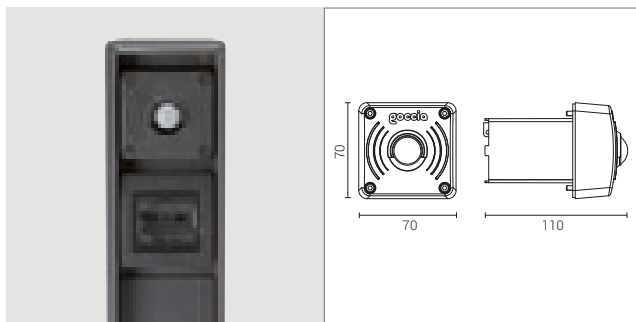

CODE	DESCRIZIONE / DESCRIPTION	GR
5308*	Rilevatore di presenza a raggi infrarossi Pir sensor	

Tre regolazioni: luminosità crepuscolare, temporizzazione, area d'intervento. Possibile accensione del faretto Led cod. 5315.

Accessorio da inserire su Server Point cod. 5301, 5302 e 5303 al posto dello sportello porta prese.

Nello sportello contrapposto non è possibile inserire prese o interruttori.
IP 65 / Classe II

CE

Three regulations: time, area, daylight. Suitable to light on code 5315 or other lamps.

To be inserted on codes 5301, 5302 and 5303 instead of the sockets door.

The opposite door cannot contain any socket or switch.

IP 65 / Class II

CE

PIASTRA TIRAFONDI | PLATE WITH ANCHORING SET

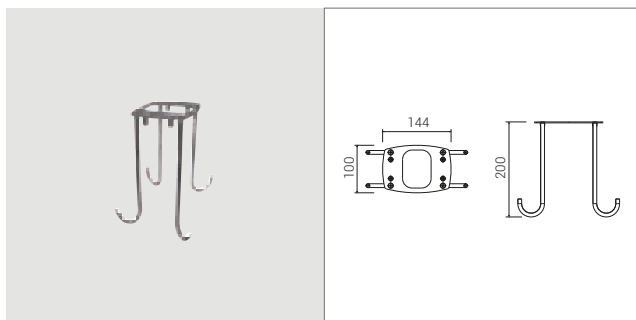

CODE	DESCRIZIONE / DESCRIPTION
5309	Piastra tirafondi Plate with anchoring set

Piastra inox con tirafondi per ancoraggio al terreno.
Pronta a montare per cod. 5301 - 5302 - 5303.

Stainless Steel plate with ground anchoring set.
Can be used on codes 5301 - 5302 - 5303.

Classe Energetica: vedi capitolo specifico.
Energy class: go to code index.

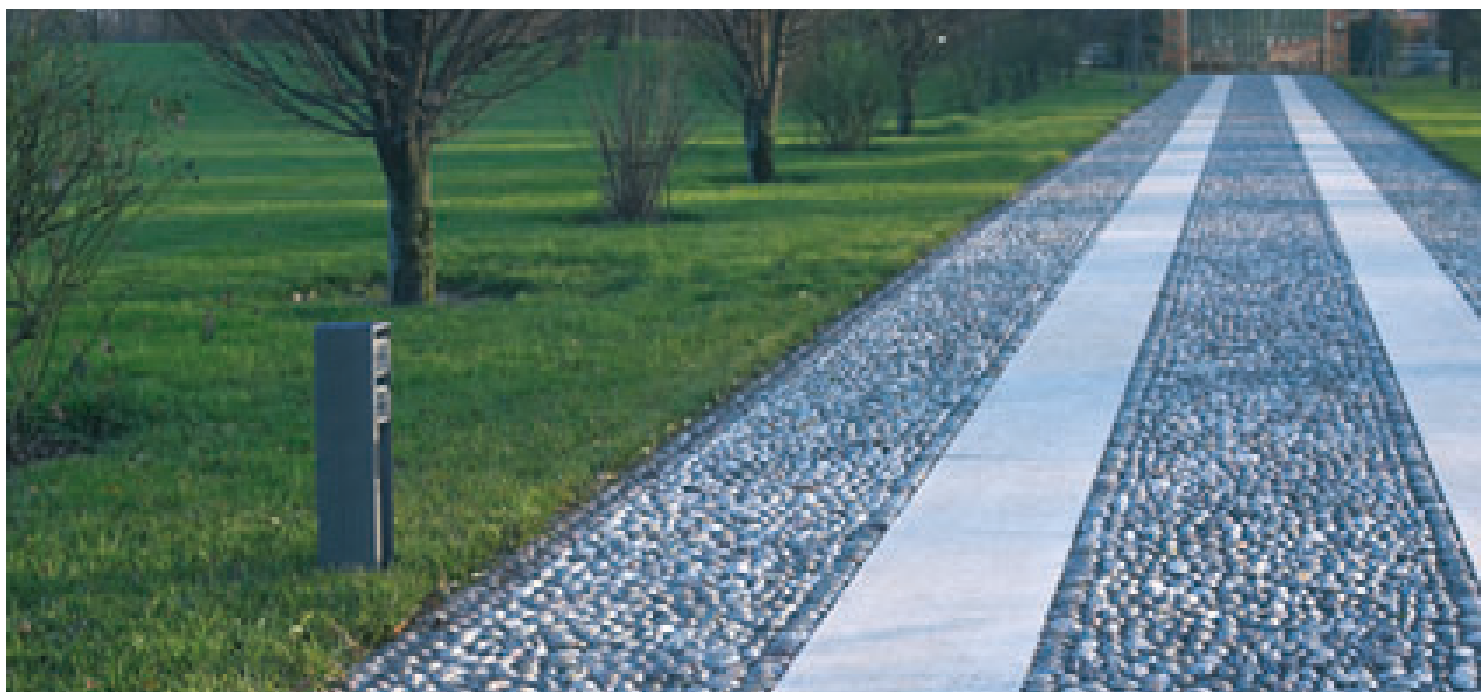



SMALL, MIDI, MAXI & SUPERMAXI

APPARECCHI DA PARETE/SOFFITTO PER ESTERNO OUTDOOR WALL/CEILING FITTINGS

Questa Serie di lampade dal design essenziale, è basata su una struttura triangolare in alluminio estruso. La linea si declina in 4 modelli con diverse lunghezze. Le versioni SMALL, MIDI e MAXI sono proposte senza o con griglia antiabbagliante, con lampade a basso consumo o con Led ad alta efficienza. La versione SUPERMAXI, con i 3 apparecchi (tutti in Classe II) di lunghezza maggiore, monta i Led di nuova generazione o i nuovi tubi fluorescenti T5, ed abbinata al modulo cieco per l'installazione alternata luce/vuoto, crea nuovi effetti scenografici. Il pratico canale porta cavi in alluminio per il montaggio di più apparecchi in fila continua, agevola il cablaggio e la precisione di posizionamento. La variante con sensore Corridor, compatibile con apparecchi predisposti per la funzione "Corridor", permette di ottenere un elevato risparmio energetico, riducendo automaticamente la luce al 10% quando non serve.

This essential design series is based on a triangular structure in extruded aluminium. The range comes in 4 models with different lengths. The SMALL, MIDI, and MAXI versions are with or without antidazzle guards, with energy saving lamps or with high efficiency LEDs. The SUPERMAXI version with 3 larger size fittings (all Class II) assembled with new generation LEDs or new T5 fluorescent tubes. The SUPERMAXI with clear tempered glass, combined with a blind module for alternating light/empty installation, creates new theatrical effects. The practical aluminium cable trunking supports the installation of multiple fittings in long lines of light, aiding wiring and positioning precision. The Corridor sensor variation, compatible with fittings pre-set for the "Corridor" function, allows high energy saving, automatically reducing light to 10% when not in use.



SMALL, MIDI, MAXI & SUPERMAXI

Apparecchi da parete/soffitto per esterno
Outdoor wall/ceiling fittings

Brevetto depositato
Registered patent

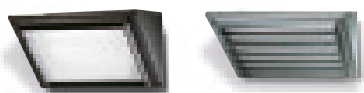

Small
LED



Midi
LED



Maxi
LED

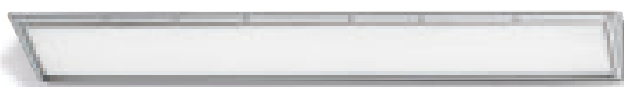

Supermaxi
LED



Supermaxi Trasparente
Clear Supermaxi
LED



Supermaxi Corridor
LED





SMALL, MIDI, MAXI & SUPERMAXI

Apparecchi da parete/soffitto per esterno
Outdoor wall/ceiling fittings

CARATTERISTICHE GENERALI

- Apparecchi da parete/soffitto per esterno di varie lunghezze.
- **Struttura:** diffusore in vetro opale temprato ultrawhite per Small, Midi e Maxi, e in policarbonato opale anti UV o vetro temprato trasparente per Supermaxi. Cornice diffusore e griglia antiabbagliamento in alluminio pressofuso. Tappi laterali in policarbonato. Corpo in alluminio estruso.
- Riflettore in alluminio 99,8 brillantato.
- Ingresso cavi dal retro o laterale dx/sx.
- **Accessori:** braccio a muro/soffitto per puntamento orientabile. Canale portacavo e supporto apparecchio per applicazioni in linea. Moduli ciechi con lo stesso corpo dell'apparecchio.
- **Modulo sensore per effetto Corridor** (10-20-30% in stato di quiete con accensione automatica al 100% al passaggio).
- **Palo** in alluminio estruso con piede e testa in alluminio pressofuso per Small, Midi e Maxi.
- **Sorgenti luminose** a basso consumo dotate di reattore elettronico o Led di nuova generazione con vita garantita 60.000 h con successivo scadimento max del 20%. Driver incorporato.
- **Finitura:** su alluminio: decappaggio + fosfocromatazione + fondo epossidico + verniciatura con polveri epossidiche stabilizzate anti UV.
- Costruito in conformità alle norme europee EN 60598-1:2015 **CE**

GENERAL FEATURES

- Various length outdoor wall/ceiling fittings.
- **Structure:** ultrawhite opal tempered glass diffuser for Small, Midi, and Maxi, and opal UV resistant polycarbonate or clear tempered glass for Supermaxi. Aluminium die-cast diffuser frame and antidazzle guard. Polycarbonate side covers. Extruded aluminium body.
- 99.8 polished aluminium reflector.
- Cable entry from either the rear or the right/left side.
- **Accessories:** wall/ceiling arm for adjustable light direction. Cable trunking and fitting support for in-line applications. Blind modules with the same body as the fitting.
- **Sensor module for Corridor effect** (10-20-30% night light with automatic ignition at 100% when sensor detects people in the area).
- Extruded aluminium **post** with die-cast aluminium base and head for Small, Midi, and Maxi.
- Low consumption **light sources** equipped with electronic ballast or new generation LEDs with minimum life 60,000 h with subsequent deterioration max 20%. Driver inside.
- **Finish:** on aluminium, pickling + phosphochrome + epoxy basic coating + UV resistant stabilised epoxy powder coating.
- Manufactured in compliance with European standards EN 60598-1:2015 **CE**

DIFFUSORE IN POLICARBONATO OPALE

Il diffusore in policarbonato opale consente la distribuzione uniforme della luce.

POLYCARBONATE DIFFUSER

The polycarbonate diffuser emanates a wide and uniform light diffusion.



DIFFUSORE IN VETRO TRASPARENTE

La serie Supermaxi è disponibile anche con il diffusore in vetro temprato trasparente, che mette in vista i corpi illuminanti con grande effetto scenico ed elevata potenza luminosa.

CLEAR GLASS DIFFUSER

Supermaxi is available with clear tempered glass with explicit evidence of the technical spare parts inside.



GRIGLIA IN ALLUMINIO

La griglia in alluminio pressofuso con diffusore in vetro temperato, disponibile per le serie Small, Midi e Maxi, è un efficace filtro antiabbagliante, senza compromettere la portata luminosa.

ALUMINIUM GUARD

The die-cast aluminium guard is available for Small, Midi and Maxi is an efficient antidazzling filter, maintaining anyway the complete light emission.



SUPERMAXI CORRIDOR

La funzione Corridor consente di eliminare automaticamente l'illuminazione inutile, grazie al circuito con rilevatore di presenza.

SUPERMAXI CORRIDOR

The Corridor function automatically eliminates non-useful illumination thanks to a pir sensor circuit



INSTALLAZIONE A CANALE

Il canale di 3,2 m consente di installare facilmente linee di lampade Supermaxi. Due staffette permettono di agganciarle al canale con un semplice gesto consentendo il posizionamento di precisione e il perfetto allineamento.

CHANNEL INSTALLATION

The 3.2 m channel allows for easy installation of Supermaxi lamp lines. Two brackets allows you to easily attach the channel, permitting precision positioning and perfect alignment.



INSTALLAZIONE A PARETE E A SOFFITTO

Con il sistema di installazione a canale è possibile posizionare le lampade a parete (1) o a soffitto (2), anche ad angolo.

WALL AND CEILING INSTALLATION

Channel installation makes it possible to position lamps on walls (1) or ceilings (2), including in corners.

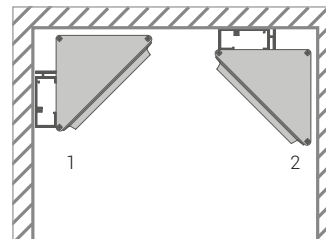

SMALL, MIDI, MAXI

Apparecchi da parete/soffitto per esterno
Outdoor wall/ceiling fittings

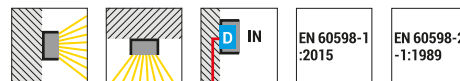

SMALL

Code + Colour

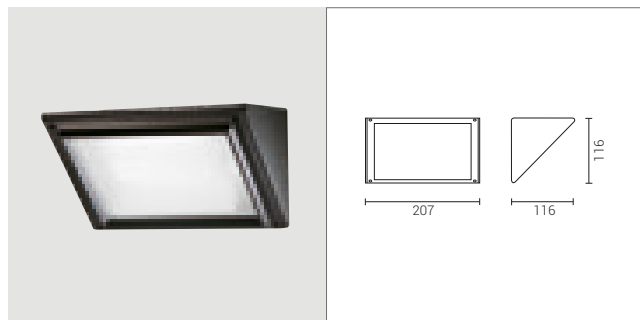

CODE	LAMP	W	NE	SI
------	------	---	----	----

5606* E 27
Dulux EI L max 130mm 60
15

Diffusore in vetro temprato.
Riflettore in alluminio 99,8 brillantato.
IP 65 / Classe I / IK 08

*Tempered opal glass diffuser.
99,8 polished aluminium reflector.
IP 65 / Class I / IK 08*

MIDI

Code + Colour

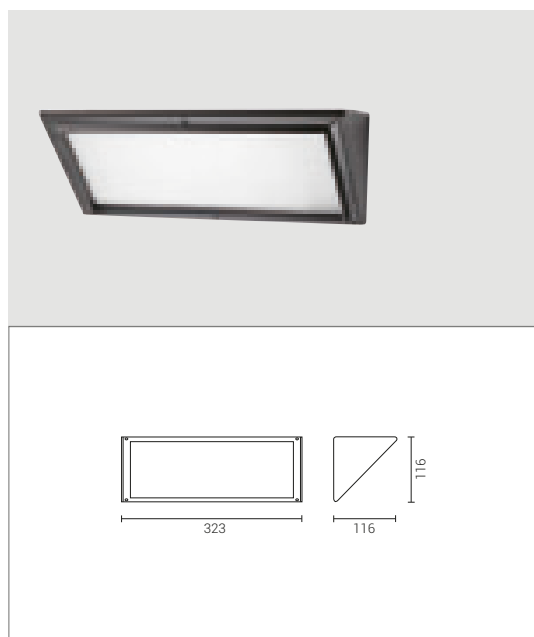

CODE	LAMP	W	NE	SI
------	------	---	----	----

5618* Reattore elettronico
Electronic ballast 2G11 18

5626* Reattore elettronico
Electronic ballast G24q-3 26

Diffusore in vetro temprato.
Riflettore in alluminio 99,8 brillantato.
Reattore elettronico.
Diffusore in policarbonato antivandalo su richiesta.
IP 65 / Classe I / IK 08

*Tempered opal glass diffuser.
99,8 polished aluminium reflector.
Electronic ballast.
Vandalproof polycarbonate diffuser on request.
IP 65 / Class I / IK 08*

MAXI

Code + Colour

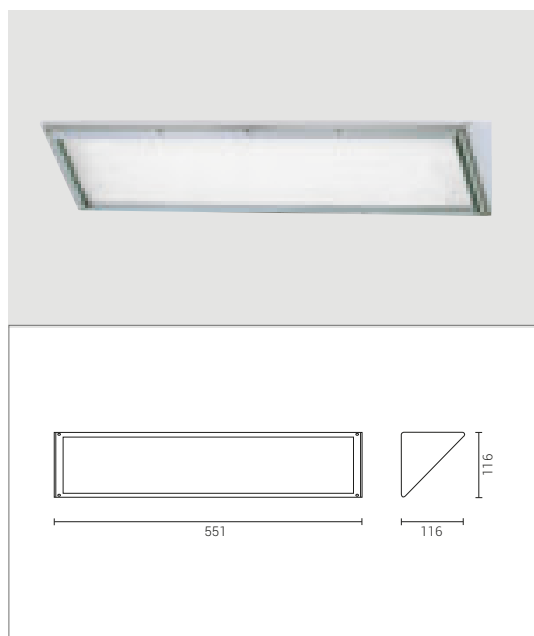

CODE	LAMP	W	NE	SI
------	------	---	----	----

5636* 2G11 36

5652* Reattore elettronico
Electronic ballast G24q-3 2x26

4473* Emergenza
Emergency 2G11 36

Diffusore in vetro temprato.
Riflettore in alluminio 99,8 brillantato.
Cod. 4473 autonomia 1h.
Esecuzione con reattore elettronico: vedi capitolo specifico.
Diffusore in policarbonato antivandalo su richiesta.
IP 65 / Classe I / IK 08

*Tempered opal glass diffuser.
99,8 polished aluminium reflector.
Code 4473 1h Life.
Electronic ballast versions: go to relevant chapter.
Vandalproof polycarbonate diffuser on request.
IP 65 / Class I / IK 08*

SMALL, MIDI, MAXI



SMALL CON GRIGLIA | SMALL WITH GUARD

Code + Colour

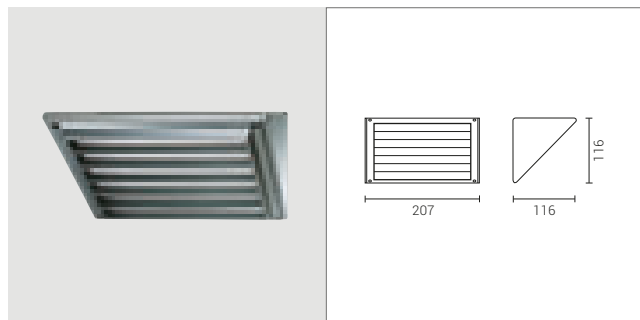

CODE	LAMP	W	NE	SI
------	------	---	----	----

5607* E 27 Dulux EI L max 130mm 60 15

Diffusore in vetro temprato.
Riflettore in alluminio 99,8 brillantato.
IP 65 / Classe I / IK 10

Tempered opal glass diffuser.
99,8 polished aluminium reflector.
IP 65 / Class I / IK 10

MIDI CON GRIGLIA | MIDI WITH GUARD

Code + Colour

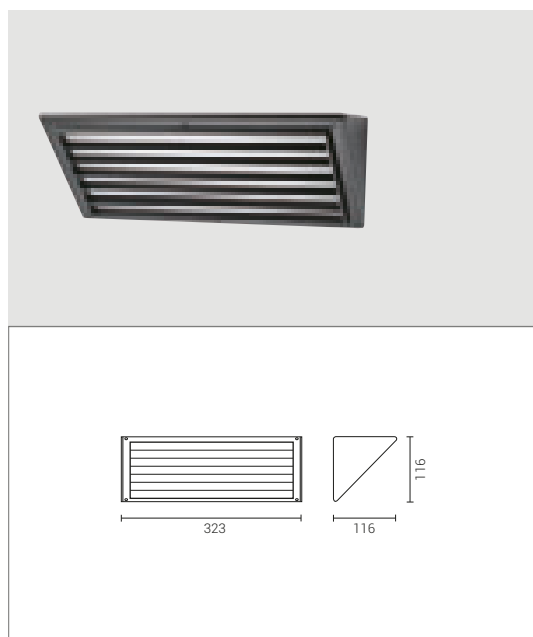

CODE	LAMP	W	NE	SI
------	------	---	----	----

5619* Reattore elettronico 2G11 Electronic ballast 18

5627* Reattore elettronico G24q-3 Electronic ballast 26

Diffusore in vetro temprato.
Riflettore in alluminio 99,8 brillantato.
Reattore elettronico.
Diffusore in policarbonato antivandalo su richiesta.
IP 65 / Classe I / IK 10

Tempered opal glass diffuser.
99,8 polished aluminium reflector.
Electronic ballast.
Vandalproof polycarbonate diffuser on request.
IP 65 / Class I / IK 10

MAXI CON GRIGLIA | MAXI WITH GUARD

Code + Colour

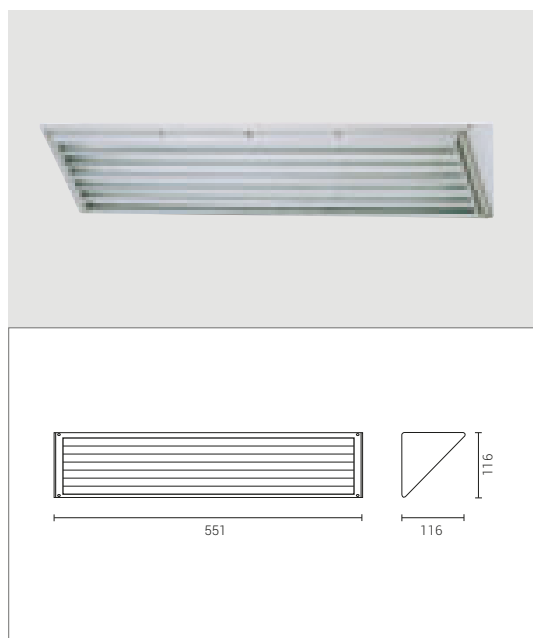

CODE	LAMP	W	NE	SI
------	------	---	----	----

5637* 2G11 36

5653* Reattore elettronico G24q-3 Electronic ballast 2x26

Diffusore in vetro temprato.
Riflettore in alluminio 99,8 brillantato.
Esecuzione con reattore elettronico: vedi capitolo specifico.
IP 65 / Classe I / IK 10

Tempered opal glass diffuser.
99,8 polished aluminium reflector.
Electronic ballast versions: go to relevant chapter.
IP 65 / Class I / IK 10

SUPERMAXI

Apparecchi da parete/soffitto per esterno
Outdoor wall/ceiling fittings



SUPERMAXI

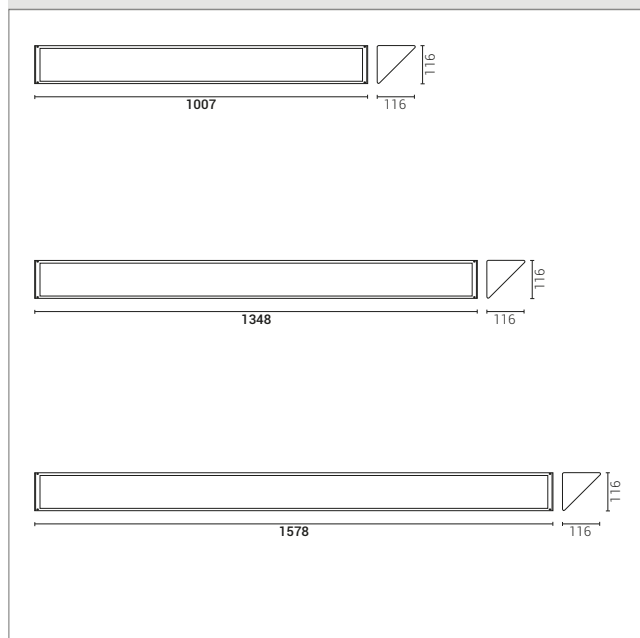

Diffusore in policarbonato opale.
Tutti gli apparecchi della serie sono dotati di reattore elettronico.

Il reattore multipotenza consente l'installazione di tubi di diverso wattaggio sullo stesso codice.

IP 65 / Classe II / IK 10

*Opal polycarbonate diffuser.
All the fittings are equipped with electronic ballast.*

The multipower ballast allows to install different wattage for the same length.

IP 65 / Class II / IK 10

CODE	LAMP	W	Code + Colour	
			NE	SI
5662*	2G11	2X36		
5663*	T5 G5 (FH)	21-39		
5666*	T5 G5 (FQ)	2X21-39		
CODE	LAMP	W	Code + Colour	
			NE	SI
5667*	T8 G13	36		
5669*	T5 G5 (FH)	28-54		
5672*	T5 G5 (FQ)	2X28-54		
CODE	LAMP	W	Code + Colour	
			NE	SI
5673*	T8 G13	58		
5675*	T5 G5 (FH)	35-49-80		
5678*	T5 G5 (FQ)	2X35-49-80		

SUPERMAXI EMERGENZA | EMERGENCY SUPERMAXI

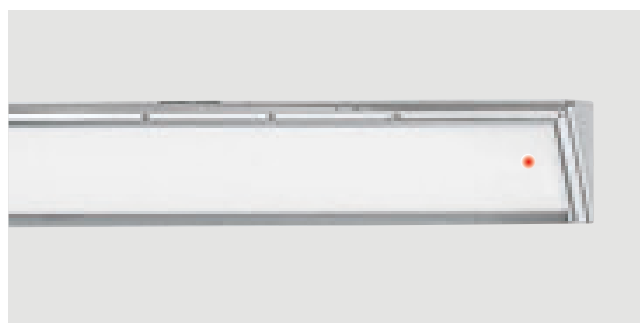

Su richiesta le lampade sopra indicate sono disponibili con funzionamento di emergenza sempre accesa.

Maintained lighting emergency available on request.

SUPERMAXI



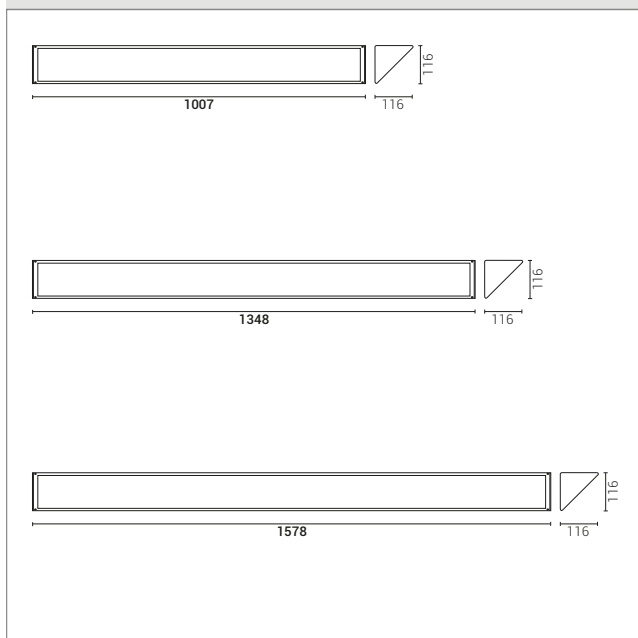
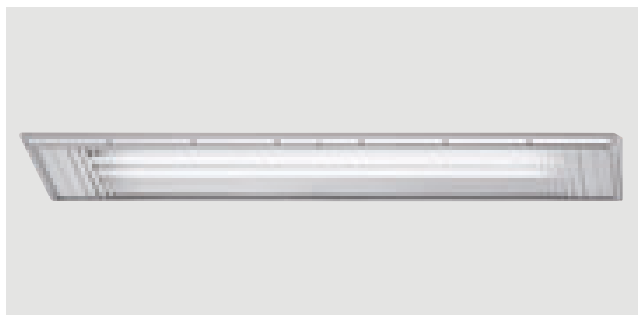

SUPERMAXI TRASPARENTE | CLEAR SUPERMAXI



Diffusore in vetro temprato trasparente. Tutti gli apparecchi della serie sono dotati di reattore elettronico.









Il reattore multipotenza consente l'installazione di tubi di diverso wattaggio sullo stesso codice.

IP 65 / Class II / IK 08
  / IK 08

Tempered clear glass diffuser. All the fittings are equipped with electronic ballast.

The multipower ballast allows to install different wattage for the same length.

IP 65 / Class II / IK 08
  / IK 08

				Code + Colour	
CODE	LAMP		W	NE	SI
5680*	 2G11		2X36		
5681*	 T5 G5 (FH)		21-39		
5683*	 T5 G5 (FQ)		2X21-39		
				Code + Colour	
CODE	LAMP		W	NE	SI
5684*	 T8 G13		36		
5685*	 T5 G5 (FH)		28-54		
5687*	 T5 G5 (FQ)		2X28-54		
				Code + Colour	
CODE	LAMP		W	NE	SI
5688*	 T8 G13		58		
5689*	 T5 G5 (FH)		35-49-80		
5699*	 T5 G5 (FQ)		2X35-49-80		

SUPERMAXI TRASPARENTE EMERGENZA | EMERGENCY CLEAR SUPERMAXI

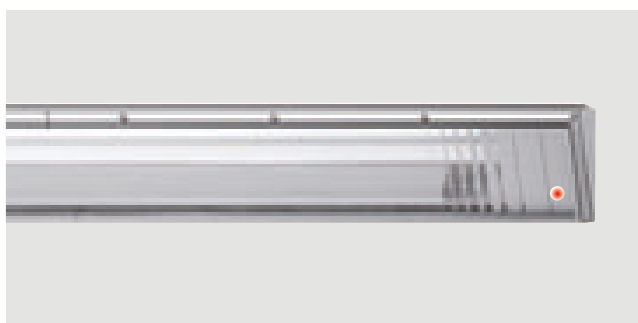

Su richiesta le lampade sopra indicate sono disponibili con funzionamento di emergenza sempre accesa.

Maintained lighting emergency available on request.

SMALL, MIDI, MAXI LED

Apparecchi da parete/soffitto per esterno
Outdoor wall/ceiling fittings



SMALL LED

Code + Colour + Tonality

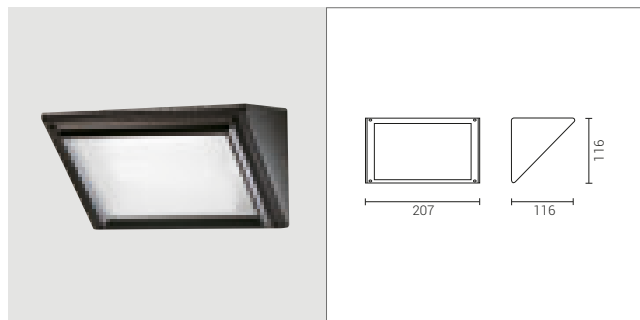

CODE	LAMP	W	lm	Nominali-Real output	NE	SI
5608*	Led	8,5	850	419		

Schermo opale con luce diffusa in vetro ultrawhite.
Sicurezza fotobiologica: gruppo di rischio 0 in accordo alla norma EN 62 471:08.
Moduli lineari Led a 24V tensione costante.
Rendimento emergenza 500 Lumen.
IP 65 / Classe II / IK 08
CRI 85 / Driver IN / 350 mA
230V / 50 Hz
CE
Tonalità 3000K o 4000K. Aggiungere 3K o 4K al codice dopo il colore.

*Opal diffuser in ultra-white glass.
Photobiologic safety: risk group 0 standard EN 62 471:08.
Linear Led modules 24V constant voltage.
Emergency efficiency: 500 Lumen.
IP 65 / Class II / IK 08
CRI 85 / Driver IN / 350 mA
230V / 50 Hz
CE
Color temperature available 3000K or 4000K. Add 3K or 4K to the code after the color.*

MIDI LED

Code + Colour + Tonality

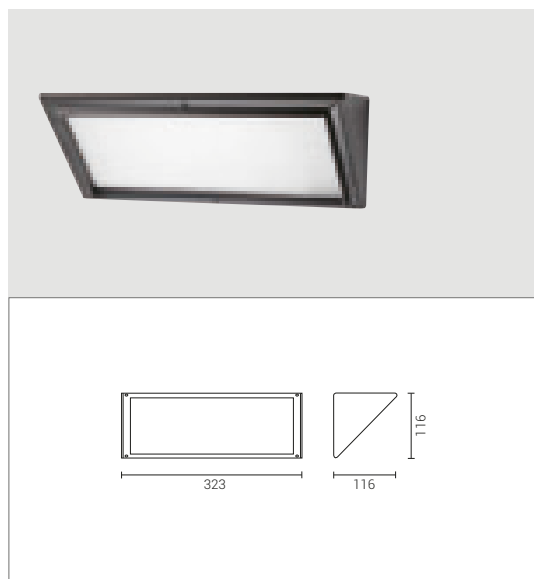

CODE	LAMP	W	lm	Nominali-Real output	NE	SI
5621*	Led	17	1700	838		

MAXI LED

Code + Colour + Tonality

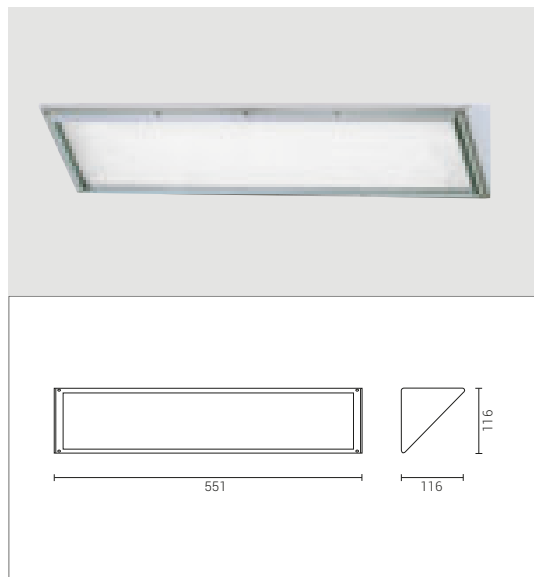

CODE	LAMP	W	lm	Nominali-Real output	NE	SI
5638*	Led	34	3400	1677		
4450*	Emergenza Emergency	34	3400/500	1677/247		

Dimmerabile a richiesta.

Dimmable on request.

SUPERMAXI LED



L80 B20
60.000

EN 60598-1
:2015

EN 60598-2
-1:1989

SUPERMAXI LED

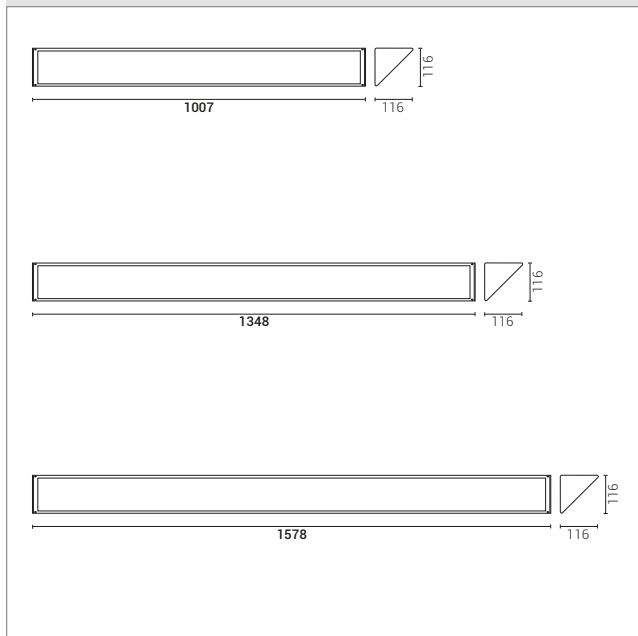

Schermo opale con luce diffusa in policarbonato.
Sicurezza fotobiologica: gruppo di rischio 0 in accordo alla norma EN 62 471:08.
Moduli lineari Led a 24V tensione costante.
Rendimento emergenza 500 Lumen.
IP 65 / Class II / IK 10
CRI 85 / Driver IN / 350 mA
230V / 50 Hz
CE
Dimmerabile a richiesta.
Tonalità 3000K o 4000K. Aggiungere 3K o 4K al codice dopo il colore.

*Opal diffuser in polycarbonate.
Photobiologic safety: risk group 0 standard EN 62 471:08.
Linear Led modules 24V constant voltage.
Emergency efficiency: 500 Lumen.
IP 65 / Class II / IK 10
CRI 85 / Driver IN / 350 mA
230V / 50 Hz
CE
Dimmable on request.
Color temperature available 3000K or 4000K. Add 3K or 4K to the code after the color.*

Code + Colour + Tonality

CODE	LAMP	W	lm	Nominali	Real output	NE	SI
5212*	XXXXXXXXXXXXXXXXXXXX Led	20	2000	1192			
5213*	XXXXXXXXXXXXXXXXXXXX Led	40	4000	2138			

Code + Colour + Tonality

CODE	LAMP	W	lm	Nominali	Real output	NE	SI
5221*	XXXXXXXXXXXXXXXXXXXX Led	29	2850	1682			
5223*	XXXXXXXXXXXXXXXXXXXX Led	58	5650	3132			

Code + Colour + Tonality

CODE	LAMP	W	lm	Nominali	Real output	NE	SI
5232*	XXXXXXXXXXXXXXXXXXXX Led	34	3400	2039			
5233*	XXXXXXXXXXXXXXXXXXXX Led	69	6800	3727			

SUPERMAXI LED EMERGENZA | EMERGENCY SUPERMAXI LED

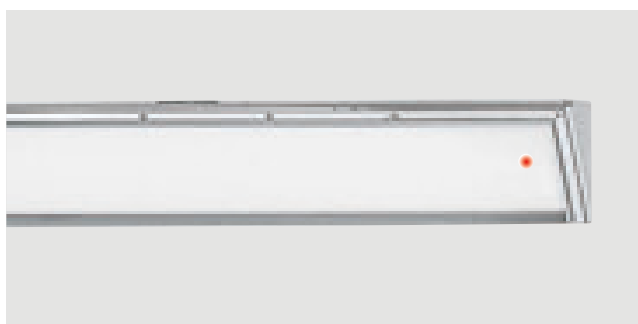

Supermaxi Led in emergenza disponibili a richiesta.

Maintained lighting emergency available on request.

SUPERMAXI CORRIDOR

Apparecchi da parete/soffitto per esterno
Outdoor wall/ceiling fittings



SUPERMAXI CORRIDOR

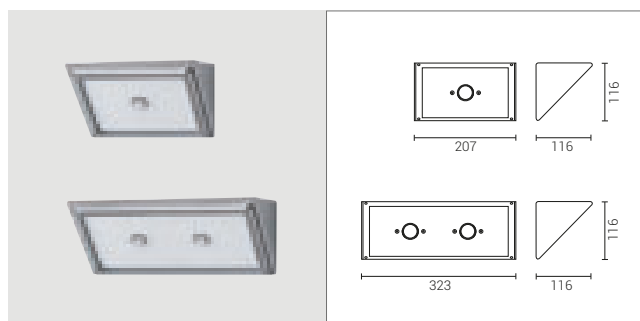

La Serie **Supermaxi** si completa con l'utilissima funzione **Corridor** che consente di eliminare l'illuminazione inutile. Grazie al particolare circuito incorporato, dotato di rilevatore di presenza, in condizioni di riposo la lampada emette il 10-20-30% di luminosità. Se una persona o un veicolo entrano nel campo del sensore la lampada viene automaticamente riportata alla massima luminosità per un tempo regolabile. Oltre alla lampada Supermaxi è previsto anche un modulo cieco da inserire lungo la linea.

*Supermaxi enlarges its range with the **Corridor** function to avoid the no- useful illumination. Thanks to a pir sensor compatible with the control gear incorporated the luminaries gives 10-20-30% of the light available, but when somebody enters in the area the light comes on to the maximum value. Switching timing can be regulated as well. Goccia offers alternatively a blind module near the lamps of the line.*

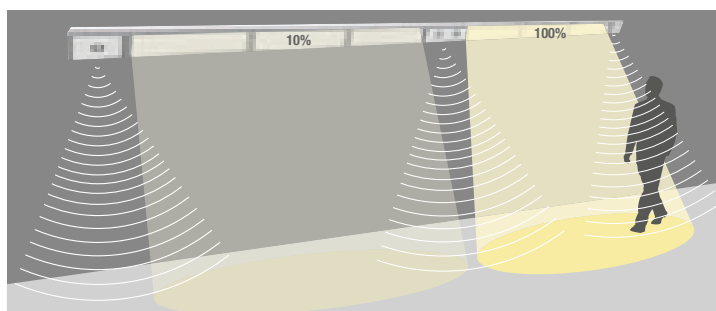

Code + Colour

CODE	DESCRIZIONE / DESCRIPTION	NE	SI
5700*	Modulo Corridor con 1 sensore <i>Corridor module with 1 sensor</i>		
5704*	Modulo Corridor con 2 sensori <i>Corridor module with 2 sensors</i>		

Diffusore in policarbonato opale. Completo di rilevatore di presenza IP 65. Addizionabile a qualunque tipo di Supermaxi che abbia un reattore Corridor compatibile. Installabile su canale Supermaxi Cod.5692. Atto a comandare 1 o più apparecchi sia con Led che con fluorescente T5. **Gli apparecchi Supermaxi abbinati devono riportare la sigla COR a lato del codice.**
IP 65 / IK 08
CE

*Opal polycarbonate diffuser. IP65 Pir Sensor incorporated. Three regulations available: daylight, area and timing. To be added to a line of Supermaxi with Corridor function. Suitable to cable trunking cod. 5692. For any type of light source it can switch on the close lamps by through wiring. **Add "COR" to the code of Supermaxi fittings when working as Corridor function.***
IP 65 / IK 08
CE



SUPERMAXI

SUPERMAXI CANALE PORTACAVI | SUPERMAXI CABLE TRUNKING

Code + Colour

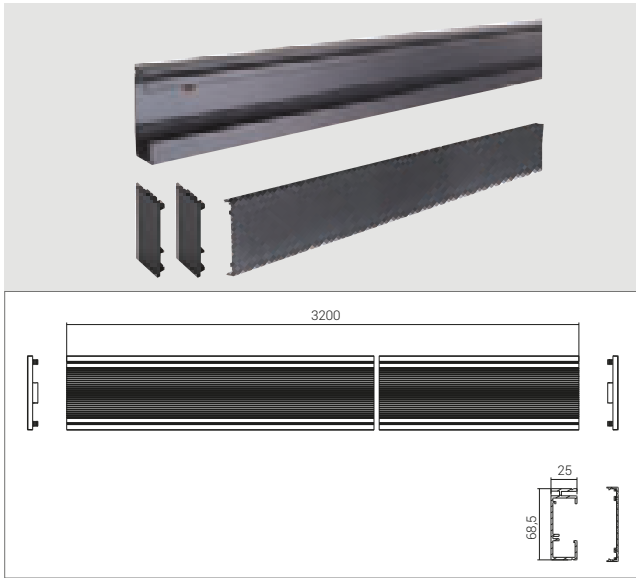

CODE DESCRIZIONE / DESCRIPTION

NE

5692* Canale portacavi / Cable trunking

5693* Tappo laterale / Side cover

5694* Coperchio di chiusura / Snapping cover

5692: Canale portacavi in alluminio. Comprensivo di 3 scatole di derivazione. 5693: Tappo laterale unico: sia destro che sinistro.

5694: Coperchio a incastro in tecnopolimero. Idoneo per l'installazione in classe II . CE

5692: Aluminium cable trunking. Each module contains 3 connection boxes. 5693: Side cover: one only type for right and left side. 5694: Tecnopolimer snapping cover.  Class II allowed. CE

SUPERMAXI STAFFETTE DI AGGANCIO | SUPERMAXI HANDLING BRACKETS

Code + Colour

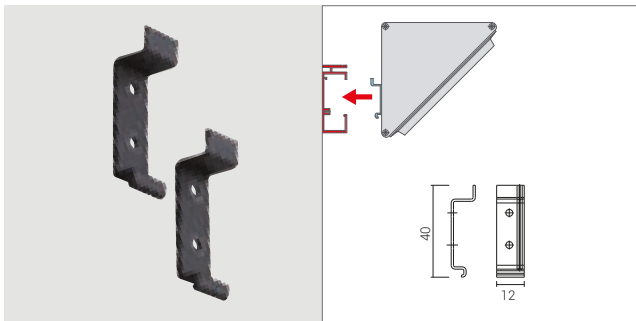

CODE DESCRIZIONE / DESCRIPTION

NE

5696* Coppia staffette di aggancio / Handling brackets pair

Coppia staffe in acciaio per predisporre Supermaxi all'aggancio sul canale 5692. Non necessitano di fori aggiuntivi su Supermaxi. Completo di morsettiere in classe II  a montare sul canale 5692.

Brackets pair to handle Supermaxi to the conduit 5692. New holes on the housing not required. Terminal block in class II  inside.

SUPERMAXI MODULO CIECO | SUPERMAXI BLIND MODULE

Code + Colour

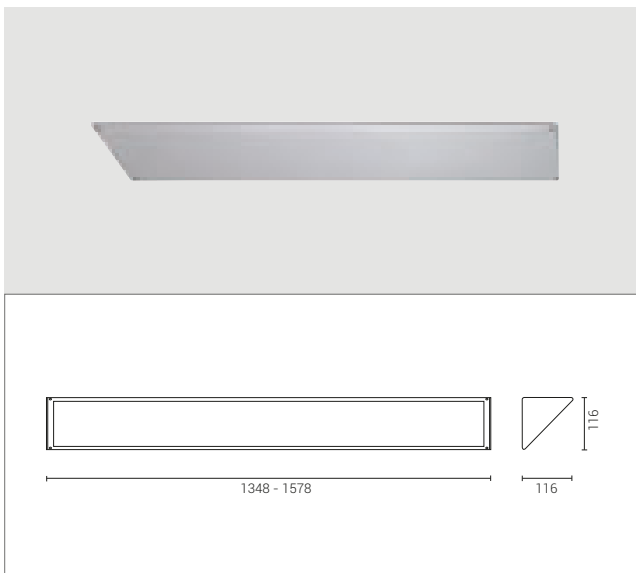



CODE DESCRIZIONE / DESCRIPTION



NE

SI

5705* Modulo cieco / Blind module 1348 mm

5708* Modulo cieco / Blind module 1578 mm

Stesso corpo in alluminio di Supermaxi. Coperchio in acciaio verniciato a fuoco. Stessi tappi laterali di Supermaxi. IP 65   

Same aluminium housing of Supermaxi. Steel cover. Same side covers of Supermaxi. IP 65   

SMALL, MIDI, MAXI, SUPERMAXI

Apparecchi da parete/soffitto per esterno
Outdoor wall/ceiling fittings

BRACCI SNODATI | ADJUSTABLE ARMS

Code + Colour

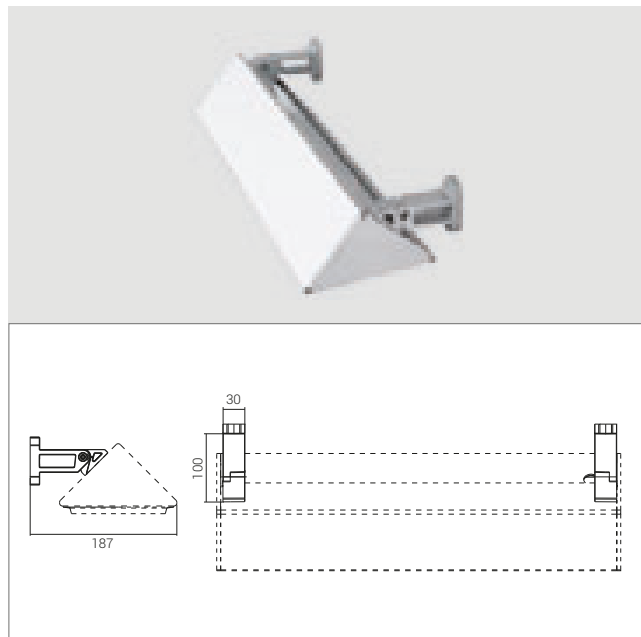

CODE DESCRIZIONE / DESCRIPTION

NE SI

5080* Coppia bracci snodati / Adjustable arms pair

Coppia di bracci snodati in alluminio
Utilizzabili su tutti gli articoli Small, Midi, Maxi e Supermaxi.
Non necessitano di fori aggiuntivi sulla lampada.
Non orientabile verso l'alto.
Completa degli accessori di montaggio.
Solo bracci: apparecchio fornito a parte.
CE

Aluminium adjustable arms pair.
Can be installed on Small, Midi, Maxi and Supermaxi.
New additional holes on the housing not required.
Mounting accessories inside.
Do not orient upwards.
Arms only: lighting fitting supplied separately.
CE

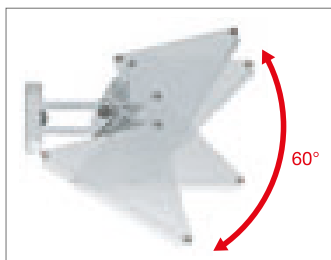

Rotazione consentita 60°.
60° rotation allowed.

STAFFA A SCATTO | SNAP BRACKET

Code + Colour

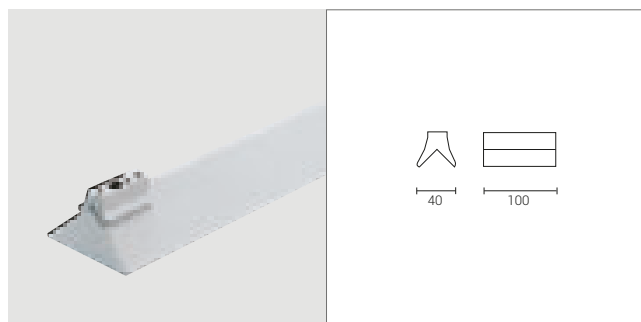

CODE DESCRIZIONE / DESCRIPTION

NE SI

5091* Staffa a scatto per fissaggio a plafone
Snap bracket for ceiling fixing

Staffa a scatto per fissaggio a plafone.
Midi-Maxi: 1 staffa sola. Supermaxi: 2 staffe.

Snap bracket for ceiling fixing.
Midi-Maxi: 1 bracket only. Supermaxi: 2 brackets.

Solo staffa: apparecchio fornito a parte.

Bracket only, lighting fitting supplied separately.

PALO SINGOLO | SINGLE POST

Code + Colour

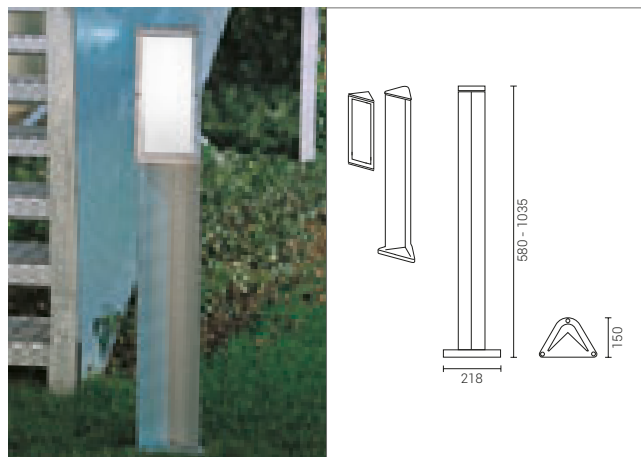

CODE DESCRIZIONE / DESCRIPTION

NE SI

3701* Palo h 580mm. Per lampade 13-18-26-36W Dulux
Post h 580mm. For 13-18-26-36W Dulux fittings

3702* Palo h 1035mm. Per lampade 18-26-36-2x36W e T5
Post h 1035mm. For 18-26-36-2x36W and T5 fittings

Sporgenza zero.
Solo palo, apparecchio Small, Midi, Maxi & Supermaxi fornito a parte.
Sottopiede anticorrosione in gomma.
CE

No protrusion.
Post only, Small, Midi, Maxi & Supermaxi fittings are supplied separately.
Rubber plate against corrosion under the base.
CE





TRIANGOLO

APPARECCHI DA PARETE/SOFFITTO E ARREDO URBANO
WALL/CEILING FITTINGS AND PUBLIC ENHANCEMENT

1987-2017: da trent'anni la Serie TRIANGOLO è un classico intramontabile di Goccia Illuminazione. L'essenziale forma triangolare ha consentito a questa serie eclettica di rimanere sempre attuale e di adattarsi alle più diverse applicazioni. Rivisitata nel 2001, la Serie è ora proposta in 3 versioni: con vetro piano per Led di potenza ad altissimo rendimento o per lampade a basso consumo; con lente di Fresnel per la diffusione asimmetrica del fascio luminoso; con lente Diamond che allarga il cono di luce. Gli apparecchi TRIANGOLO sono disponibili in 2 dimensioni: piccola, con il corpo in policarbonato; grande, completamente in alluminio pressofuso. La più recente versione a Led di potenza è stata progettata per ottenere una dissipazione ideale del calore, necessaria per consentire le altissime prestazioni luminose. Il riflettore in alluminio brillantato è stato ridisegnato per la più uniforme diffusione della luce. Gli apparecchi TRIANGOLO grande in alluminio, abbinati ai pali della serie City, sono la scelta ideale per l'illuminazione intelligente di spazi di arredo urbano.

1987-2017: For the past thirty years, the TRIANGOLO series has been a timeless classic by Goccia Illuminazione. Its simple triangular shape has allowed this eclectic series to always stay current and adapt to different applications. After its restyling in 2001, the Series is now offered in 3 versions: with flat glass for very high efficiency power LEDs or for energy saving lamps, with Fresnel lens for asymmetric distribution of light beams, or with Diamond lens to enlarge the cone of light. TRIANGOLO fittings are available in 2 sizes: small, with a polycarbonate body, or large, completely in die-cast aluminium. The most recent power LED version has been designed to obtain ideal heat dissipation, necessary for excellent lighting performance. The polished aluminium reflector has been re-designed for more even light distribution. Large TRIANGOLO aluminium fittings combined with City series posts are the ideal choice for intelligent lighting of urban areas.





TRIANGOLO

Apparecchi da parete/soffitto per esterno
Outdoor wall/ceiling fittings

Brevetto depositato
Registered patent

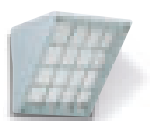

Triangolo piccolo
Small Triangolo

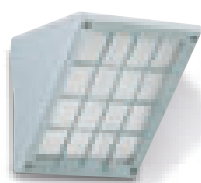

Triangolo grande
Large Triangolo



Triangolo piccolo
diffusore Fresnel
*Small Triangolo
Fresnel lens*

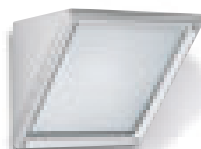

Triangolo grande
diffusore Fresnel
*Large Triangolo
Fresnel lens*



Triangolo piccolo
diffusore Diamond
*Small Triangolo
Diamond lens*

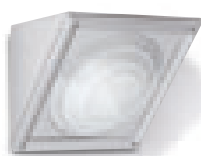

Triangolo grande
diffusore Diamond
*Large Triangolo
Diamond lens*



Triangolo piccolo Led
Small Triangolo Led
LED

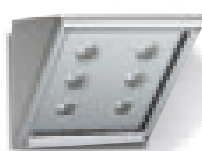

Triangolo grande Led
Large Triangolo Led
LED

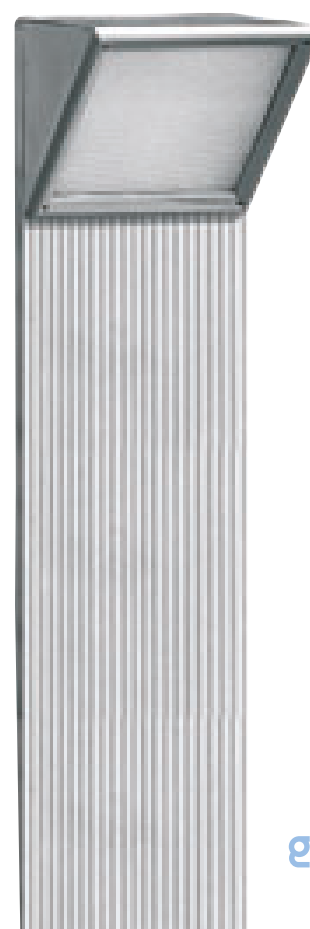



TRIANGOLO

Apparecchi da parete/soffitto per esterno
Outdoor wall/ceiling fittings

CARATTERISTICHE GENERALI

- Apparecchio da parete per esterno.
- **Struttura:** diffusore in vetro ultrawhite opale temprato o trasparente con lavorazione a lente di Fresnel o a Diamante per dirigere il fascio luminoso in varie posizioni. Per Triangolo Grande, corpo e cornice fermavetro in alluminio pressofuso a basso tenore di rame. Per Triangolo Piccolo, corpo e cornice fermavetro in policarbonato.
- Ingresso cavi dal retro.
- **Piantane** da giardino in alluminio.
- **Sorgenti luminose:** a basso consumo in varie versioni e a **Led di nuova generazione** con vetro opale per l'omogenea distribuzione della luce. Vita garantita 60.000 h con successivo scadimento max del 20%. Driver incorporato.
- **Finitura:** per alluminio, decappaggio + fosfocromatazione + fondo epossidico + verniciatura con polveri epossidiche stabilizzate anti UV.
- Costruito in conformità alle norme europee EN 60598-1:2015 **CE**

GENERAL FEATURES

- Wall fitting for outdoors.
- **Structure:** ultrawhite opal or transparent tempered glass diffuser with Fresnel or Diamante lens processing to direct angle beams in various positions. For Large Triangolo, die-cast aluminium body and glazing bead frame with low copper content. For Small Triangolo, polycarbonate body and glazing bead frame.
- Cable entry from the back.
- **Aluminium garden posts.**
- **Light sources:** low consumption in various versions and in **new generation LED** with opal glass for even light distribution. Minimum life 60,000 h with subsequent deterioration max 20%. Driver inside.
- **Finish:** for aluminium, pickling + phosphochrome + epoxy basic coating + UV resistant stabilised epoxy powder coating.
- **Manufactured in compliance with European standards EN 60598-1:2015 CE**

I LED DI POTENZA ARRICCHISCONO LA SERIE TRIANGOLO

- 1 - Scocca in alluminio o policarbonato
- 2 - Riflettore
- 3 - Led di potenza
- 4 - Dissipatore di calore
- 5 - Guarnizioni in silicone
- 6 - Diffusore in vetro temprato

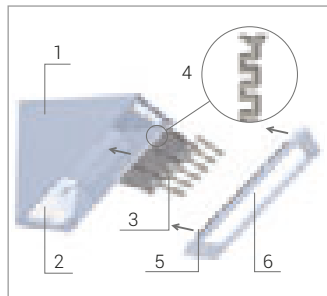

NEW POWER LEDS IMPROVE THE TRIANGOLO RANGE

- 1 - Aluminium or polycarbonate housing
- 2 - Reflector
- 3 - Power led
- 4 - Heat sink
- 5 - Silicone gasket
- 6 - Tempered opal glass diffuser

DIFFUSORE FRESNEL

Il diffusore, in virtù di un accurato studio ottico, devia il raggio luminoso verso il basso di 30° rispetto al diffusore normale. Ruotando il diffusore di 180° l'effetto si inverte.



FRESNEL

Thanks to the optical engineering such lens refracts and deviates the directions of the light for 30°. If you rotate the glass of 180° the effect will be reverted.

DIFFUSORE DIAMOND

La forma preziosa ed elegante del diffusore in vetro è frutto di approfonditi studi illuminotecnici e consente di diffondere lateralmente la luce con la massima angolazione possibile.

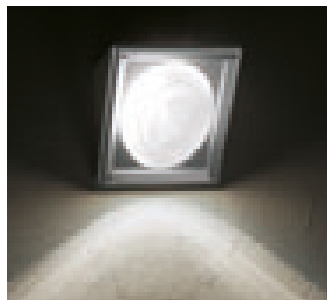

DIAMOND

Thanks to an accurate project such lens, so precious and elegant, is capable to widen the lighting distribution.

IP65

Tutte le lampade della Serie Triangolo sono a tenuta stagna IP65.



IP65

All Triangolo series lamps are IP65 watertight.

DESIGN ACCURATO

Linee morbide con angoli smussati.



SOPHISTICATED DESIGN

Soft lines and corners.

ALIMENTAZIONE LATERALE

Possibilità di alimentazione con ingresso laterale.



SIDE POWER

Side cable entry available.



TRIANGOLO LED

Apparecchi da parete/soffitto per esterno
Outdoor wall/ceiling fittings

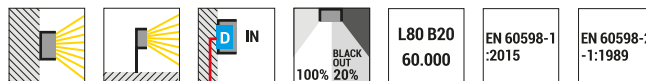

TRIANGOLO PICCOLO LED POLICARBONATO | SMALL TRIANGOLO LED IN POLYCARBONATE

Code + Colour + Tonality

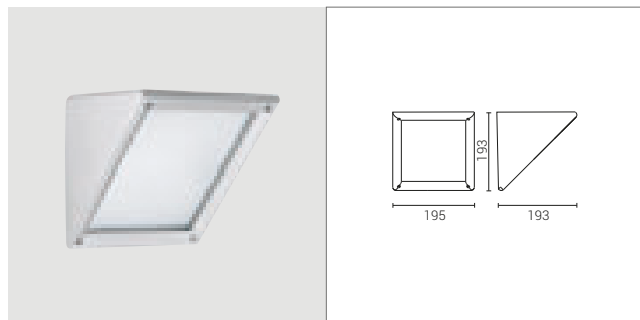

CODE	LAMP	W	Im Nominali-Real output	GR	SI
4220*	Led	10	1000 496		

Diffusore in vetro piano temprato e opale.
Sicurezza fotobiologica: gruppo di rischio 0 in accordo alla norma EN 62 471:08.
4 moduli lineari Led 24V tensione costante.
Apertura del fascio luminoso: 90°.
IP 65 / Classe II / IK 08
CRI 85 / Driver IN / 350 mA
230V / 50 Hz
C€
Tonality 3000K o 4000K. Aggiungere 3K o 4K al codice dopo il colore.

*Diffuser in opal tempered glass.
Photobiologic safety: risk group 0 standard EN 62471:08.
4 linear Led modules 24V constant voltage.
90° angle beam.
IP 65 / Class II / IK 08
CRI 85 / Driver IN / 350 mA
230V / 50 Hz
C€
Color temperature available 3000K or 4000K. Add 3K or 4K to the code after the color.*

TRIANGOLO GRANDE LED ALLUMINIO | LARGE TRIANGOLO LED IN ALUMINIUM

Code + Colour + Tonality

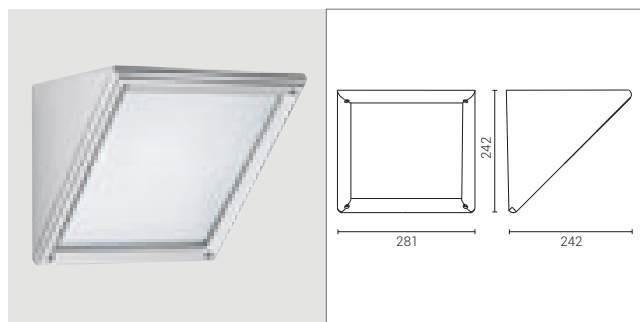

CODE	LAMP	W	Im Nominali - Real output	GR	SI
4223*	Led	34,5	3400 1684		
4229*	Emergenza Emergency	34,5	3400/350 1684/173		

Diffusore in vetro piano temprato e opale.
Sicurezza fotobiologica: gruppo di rischio 0 in accordo alla norma EN 62 471:08.
6 moduli lineari Led 24V tensione costante.
Apertura del fascio luminoso: 90°.
IP 65 / Classe II / IK 08
CRI 85 / Driver IN / 350 mA
230V / 50 Hz
C€
Tonality 3000K o 4000K. Aggiungere 3K o 4K al codice dopo il colore.

*Diffuser in opal tempered glass.
Photobiologic safety: risk group 0 standard EN 62471:08.
6 linear Led modules 24V constant voltage.
90° angle beam.
IP 65 / Class II / IK 08
CRI 85 / Driver IN / 350 mA
230V / 50 Hz
C€
Color temperature available 3000K or 4000K. Add 3K or 4K to the code after the color.*

TRIANGOLO GRANDE LED ALLUMINIO | LARGE TRIANGOLO LED IN ALUMINIUM

Code + Colour + Tonality

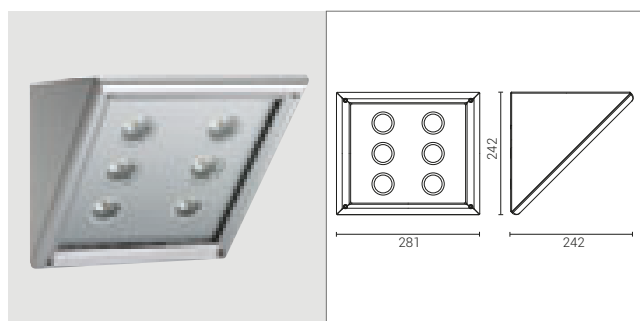

CODE	LAMP	W	Im Nominali-Real output	GR	SI
4224*	Led	6x6,5	3960 3372		

Vetro temprato trasparente.
6 gruppi Led da 6,5W e 660 lumen ciascuno. 39W e 3960 lumen totali.
Collegamento in parallelo per 2 driver.
IP 65 / Classe II / IK 08
CRI 85 / Driver IN / 350 mA
230V / 50 Hz
C€
Tonality 3000K o 4000K. Aggiungere 3K o 4K al codice dopo il colore.

*Clear tempered glass.
6 led units 6,5 W 660 lumen each. 39W 3960 lumen totaly. 220-250V 50-60Hz 350mA drivers incorporated.
Two independent parallel wiring.
IP 65 / Class II / IK 08
CRI 85 / Driver IN / 350 mA
230V / 50 Hz
C€
Color temperature available 3000K or 4000K. Add 3K or 4K to the code after the color.*

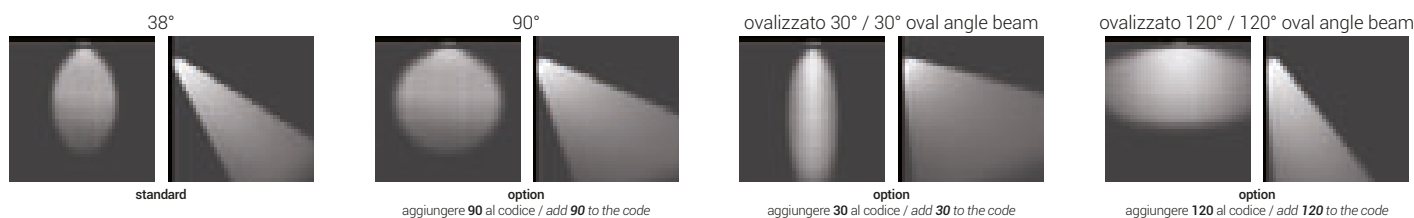

I due fasci ovalizzati si ottengono girando di 90° la stessa lente Fresnel.
The two oval angle beams come by the same Fresnel lens rotated of 90°.

TRIANGOLO

Apparecchi da parete/soffitto per esterno
Outdoor wall/ceiling fittings



TRIANGOLO PICCOLO POLICARBONATO | SMALL TRIANGOLO IN POLYCARBONATE

Code + Colour

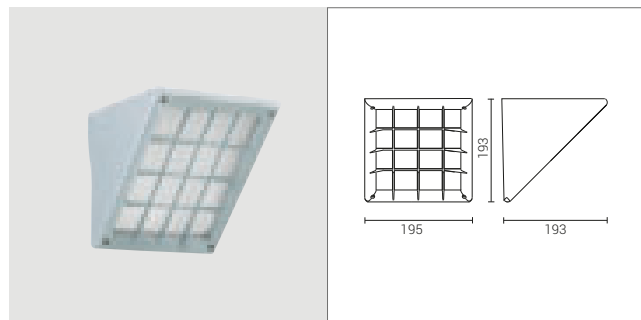

CODE	LAMP	W	GR	SI
4160 *	E 27 Dulux EI	L max 120mm 75 11		
4163 *	G24d-1	2x13		

Finitura a spruzzo stabilizzata UV.
IP 65 / Classe II per cod.
4160 / IK 08
CE

UV resistant spray painting.
IP 65 / Class II for code 4160 /
IK 08
CE

TRIANGOLO GRANDE ALLUMINIO | LARGE TRIANGOLO IN ALUMINIUM

Code + Colour

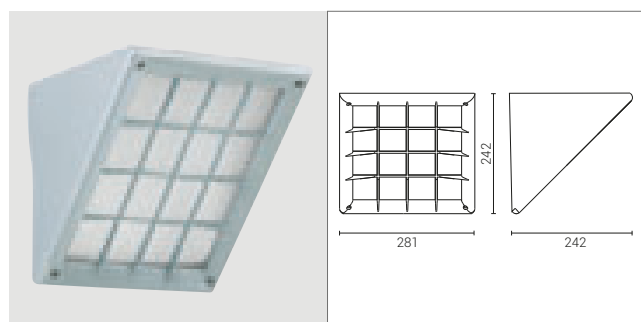

CODE	LAMP	W	GR	SI
4210 *	E 27 Dulux EI	L max 190mm 150 23		
4211 *	2G11	2x18		
4214 *	Alimentazione elettronica Electronic ballast	Gx24q-4 2x26-32-42		
4215 *	Ioduri metallici Metal halide	Rx7s 70		
4216 *	Ioduri metallici Metal halide	Rx7s-24 150		
4217 *	Sodio alta pressione High press. sodium	E27 70		
4218 *	Sodio alta pressione High press. sodium	E40 150		
4431 *	Emergenza 1h Emergency 1h	2G11 2x18		
4432 *	Emergenza 3h Emergency 3h	2G11 2x18		

Verniciatura a polvere dopo
fosfocromatazione stabilizzata UV.
Possibilità di ingresso laterale.
Per art. 4214 utilizzare soltanto
lampadine ad amalgama.
IP 65 / Classe II per cod.
4210/4215/4216/4217/4218 / IK 08
CE

Pre-phosphochromed UV resistant
painting.
Side cable entry available.
Code 4214: utilize only amalgam lamps.
IP 65 / Class II for codes
4210/4215/4216/4217/4218 / IK 08
CE

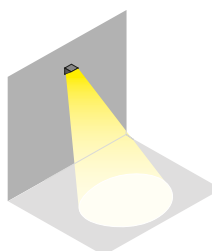

Diffusore normale
Normal lens

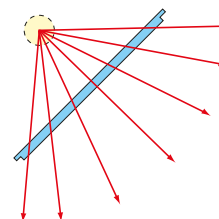

TRIANGOLO



TRIANGOLO FRESNEL PICCOLO POLICARBONATO | SMALL TRIANGOLO FRESNEL IN POLYCARBONATE

Code + Colour

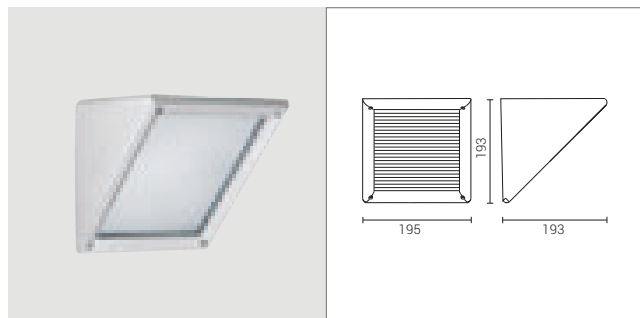

CODE	LAMP	W	GR	SI
4170 *	E 27 Dulux EI	L max 120mm 75 11		
4173 *	G24d-1	2x13		

Diffusore rifrattore in vetro stampato, rettificato e temprato. Possibilità di ruotare il vetro di 180° per invertire l'effetto rifrattore.
Finitura a spruzzo stabilizzata UV.
IP 65 / Class II per cod. 4170 / IK 08
CE

Reflector lens in rectified tempered glass. You can revert the effect to the opposite direction if you rotate the glass 180°. UV resistant spray painting.
IP 65 / Class II for code 4170 / IK 08
CE

TRIANGOLO FRESNEL GRANDE ALLUMINIO | LARGE TRIANGOLO FRESNEL IN ALUMINIUM

Code + Colour

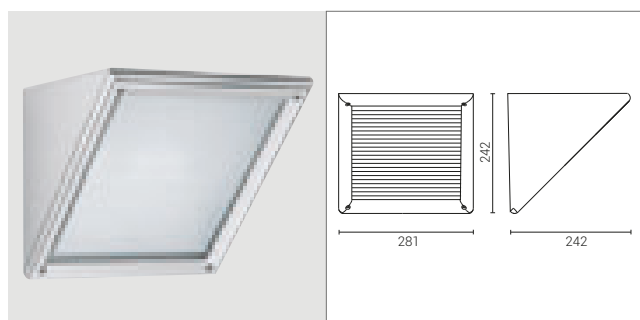

CODE	LAMP	W	GR	SI
4230 *	E 27 Dulux EI	L max 190mm 150 23		
4231 *	2G11	2x18		
4234 *	Alimentazione elettronica Electronic ballast	Gx24q-4	2x26-32-42	
4235 *	Ioduri metallici Metal halide	Rx7s	70	
4236 *	Ioduri metallici Metal halide	Rx7s-24	150	
4237 *	Sodio alta pressione High press. sodium	E27	70	
4238 *	Sodio alta pressione High press. sodium	E40	150	
4433 *	Emergenza 1h Emergency 1h	2G11	2x18	
4434 *	Emergenza 3h Emergency 3h	2G11	2x18	

Diffusore in vetro stampato, rettificato e temprato. Possibilità di ruotare il vetro di 180° per invertire l'effetto rifrattore. Verniciatura a polvere dopo fosfocromatazione stabilizzata UV. Possibilità di ingresso laterale. Per art. 4234 utilizzare soltanto lampadine ad amalgama.
IP 65 / Class II per art. 4230/4235/4236/4237/4238 / IK 08
CE

Reflector lens in rectified tempered glass. You can revert the effect to the opposite direction if you rotate the glass 180°. Pre-phosphochromed UV resistant painting. Side cable entry available. Code 4234: utilize only amalgam lamps.
IP 65 / Class II for codes 4230/4235/4236/4237/4238 / IK 08
CE

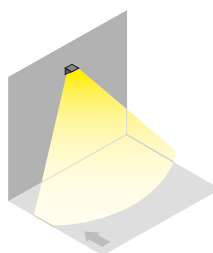

Diffusore Fresnel verso l'interno
Fresnel lens to the inside

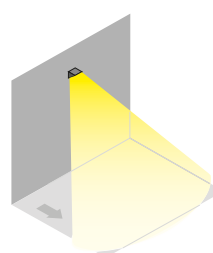

Diffusore Fresnel ruotato di 180°
Fresnel lens 180° rotated

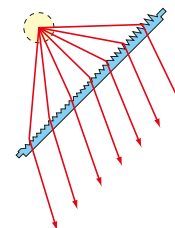

TRIANGOLO

Apparecchi da parete/soffitto per esterno
Outdoor wall/ceiling fittings



TRIANGOLO DIAMOND PICCOLO POLICARBONATO | SMALL TRIANGOLO DIAMOND IN POLYCARBONATE

Code + Colour

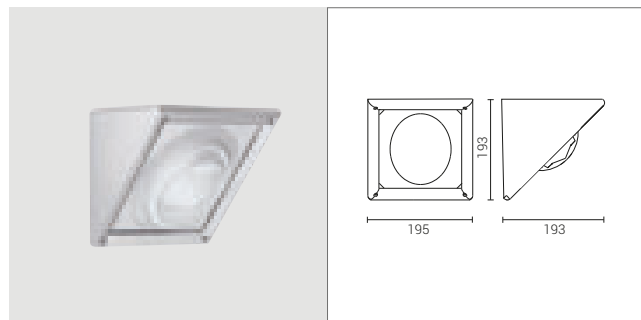

CODE	LAMP	W	GR	SI
4180 *	E 27 Dulux EI L max 120mm	75 11		
4183 *	G24d-1	2x13		

Diffusore diffondente a bolla in vetro stampato e temprato.
Finitura a spruzzo stabilizzata UV.
IP 65 / Classe II per cod. 4180 / IK 08
CE

*Prismatic, clear and widening diffuser in rectified and tempered glass.
UV resistant spray painting.
IP 65 / Class II for code 4180 / IK 08
CE*

TRIANGOLO DIAMOND GRANDE ALLUMINIO | LARGE TRIANGOLO DIAMOND IN ALUMINIUM

Code + Colour

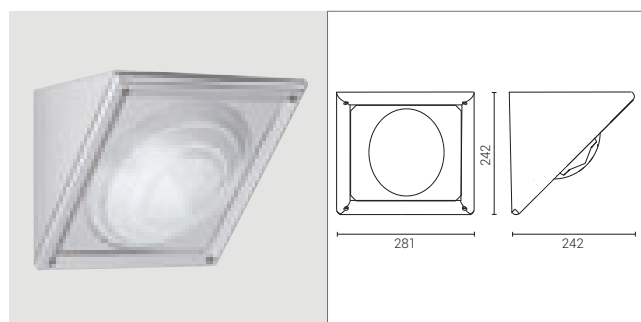

CODE	LAMP	W	GR	SI
4250 *	E 27 Dulux EI L max 190mm	150 23		
4251 *	2G11	2x18		
4254 *	Alimentazione elettronica Electronic ballast Gx24q-4	2x26-32-42		
4255 *	Ioduri metallici Metal halide Rx7s	70		
4256 *	Ioduri metallici Metal halide Rx7s-24	150		
4257 *	Sodio alta pressione High press. sodium E27	70		
4258 *	Sodio alta pressione High press. sodium E40	150		
4435 *	Emergenza 1h Emergency 1h 2G11	2x18		
4436 *	Emergenza 3h Emergency 3h 2G11	2x18		

Diffusore diffondente a bolla in vetro stampato e temprato. Verniciatura a polvere dopo fosfocromatazione stabilizzata UV.
Possibilità di ingresso laterale.
Per cod. 4254 utilizzare soltanto lampadine ad amalgama.
IP 65 / Classe II per cod. 4250/4255/4256/4257/4258 / IK 08
CE

*Prismatic, clear and widening diffuser in rectified and tempered glass.
Pre-phosphochromed UV resistant painting.
Side cable entry available.
Code 4254: utilize only amalgam lamps.
IP 65 / Class II for codes 4250/4255/4256/4257/4258 / IK 08
CE*

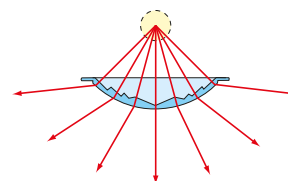
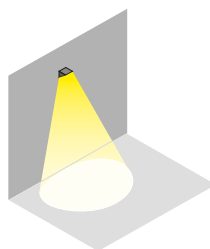

Diffusore Diamond
Diamond lens

TRIANGOLO

PIANTANA | GARDEN POST

Code + Colour

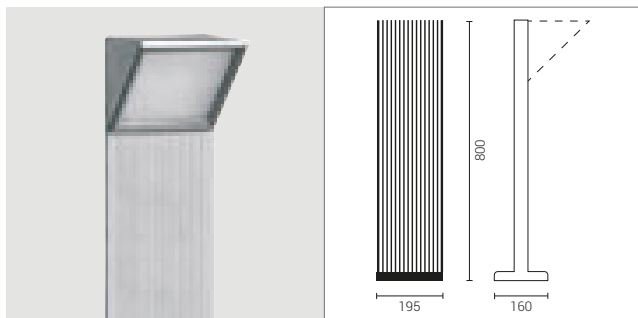

CODE DESCRIZIONE / DESCRIPTION

GR SI

3341* Piantana per 1 o 2 Triangolo Piccolo in policarbonato
Post for 1 or 2 Small Triangolo in polycarbonate

Struttura in alluminio estruso. Testa palo e basetta in alluminio pressofuso.
È possibile montare un secondo Triangolo contrapposto.
Completo di cassetta di derivazione incassata nella struttura con porta fusibile.
Sottopiede anticorrosione in gomma.
Trattamento superficiale anti UV e anticorrosione.

Solo piantana, apparecchio Triangolo fornito separatamente.

€€

Post in extruded aluminium. Top cover and base in die-cast aluminium.

A second Triangolo can be installed as well.

Recessed junction box included, complete with fuse-holder.

Rubber plate against corrosion under the base.

UV and corrosion resistant finish.

€€

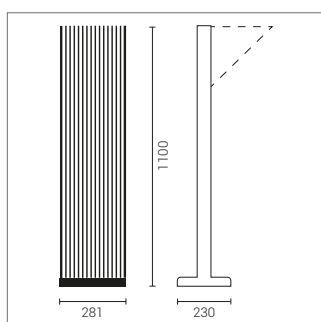

CODE DESCRIZIONE / DESCRIPTION

GR SI

3344* Piantana per 1 o 2 Triangolo Grande in alluminio
Post for 1 or 2 Large Triangolo in aluminium





TRIANGOLO CITY

Arredo urbano
Pathways and park luminaires



Palo a 2 montanti
2 Posts structure



Triangolo City Corridor



Braccio
Adjustable arm



TRIANGOLO CITY

Arredo urbano
Pathways and park luminaires

CARATTERISTICHE GENERALI

- Palo a doppio montante per arredo urbano.
- **Struttura:** interamente in alluminio estruso e lavorato a laser da lastra. Assemblato senza saldature mediante accoppiamento vite/inserto inox da M8 e M10. Basamento completo di scatola di derivazione per alimentazione passante. Passaggio cavi di alimentazione all'interno della struttura.
- Può ricevere 1 o 2 apparecchi della Serie Triangolo Grande con o senza braccio.
- **Versione con effetto Corridor** mediante sensore nel basamento (10-20-30% in stato di quiete con accensione automatica al 100% al passaggio).
- **Sorgenti luminose** (vedi Serie Triangolo): a basso consumo o **Led di nuova generazione** con vita garantita 60.000 h con successivo scadimento max del 20%. Driver incorporato
- **Finitura:** su alluminio, decappaggio + fosfocromatazione + fondo epossidico + verniciatura con polveri epossidiche stabilizzate anti UV.
- Costruito in conformità alle norme europee EN 40-6:2002 **CE**

GENERAL FEATURES

- *Dual post for urban enhancement.*
- **Structure:** entirely in extruded aluminium and slab laser processed. Assembled without welding with screw/M8 and M10 stainless steel insert coupling. Base complete with junction box for through power. Through power wiring inside structure.
- *Can receive 1 or 2 Large Triangolo series fittings with or without arm.*
- **Version with Corridor effect** via sensor in base (10-20-30% night light with automatic ignition at 100% when sensor detects people in the area).
- **Light sources** (see Triangolo Series): energy savings or **new generation LEDs** with minimum life 60,000 h with subsequent deterioration max 20%. Driver inside
- **Finish:** on aluminium, pickling + phosphochrome + epoxy basic coating + UV resistant stabilised epoxy powder coating.
- *Manufactured in compliance with European standards EN 40-6:2002 **CE***

TRIANGOLO CITY CON LAMPADINE TRIANGOLO GRANDE IN ALLUMINIO O POLICARBONATO

- 1 - Una lampada
- 2 - Due lampade
- 3 - Due lampade ad angolo

TRIANGOLO CITY WITH LARGE TRIANGOLO FITTINGS IN ALUMINIUM OR POLYCARBONATE

- 1 - One fitting
- 2 - Two fittings
- 3 - Two corner fittings

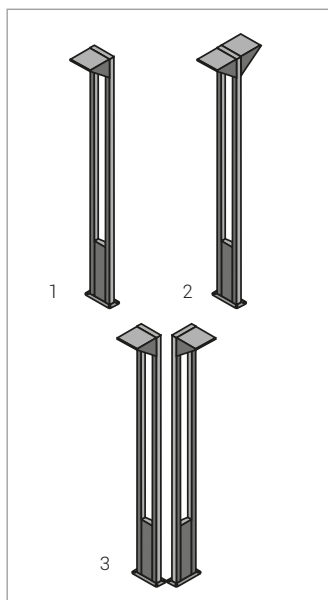

TRIANGOLO CITY CON BRACCI E LAMPADINE TRIANGOLO GRANDE ESCLUSIVAMENTE IN ALLUMINIO

- 1 - Un braccio
- 2 - Due bracci
- 3 - Due bracci ad angolo

TRIANGOLO CITY WITH ARMS AND LARGE TRIANGOLO FITTINGS IN ALUMINIUM ONLY

- 1 - One arm
- 2 - Two arms
- 3 - Two corner arms

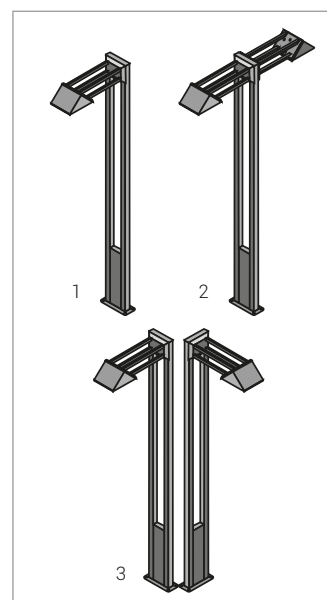

TRIANGOLO CITY CORRIDOR

La funzione Corridor consente di eliminare automaticamente l'illuminazione inutile, grazie al circuito con rilevatore di presenza.

TRIANGOLO CITY CORRIDOR

The Corridor function automatically eliminates non-useful illumination thanks to a pir sensor circuit.

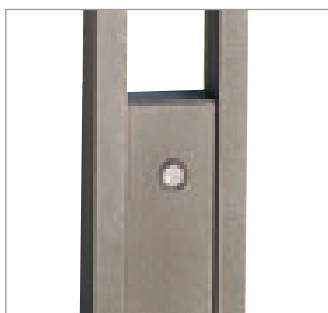

BRACCIO ORIENTABILE

Braccio orientabile da 0° a 45°.

ADJUSTABLE ARM

Adjustable arm from 0° to 45°.

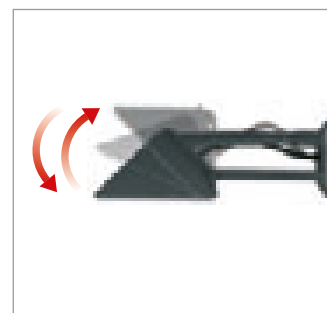

TRIANGOLO CITY

Arredo urbano
Pathways and park luminaires



TRIANGOLO CITY A 2 MONTANTI CON PIEDE | 2 POSTS TRIANGOLO CITY WITH BASE

Code + Colour

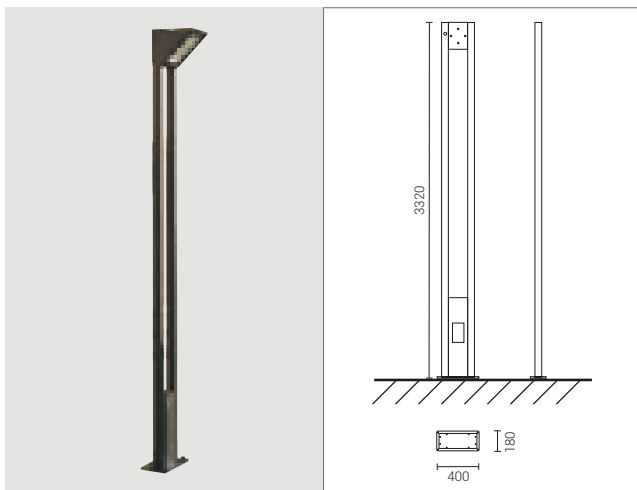

CODE DESCRIZIONE / DESCRIPTION GR

3351* Solo struttura / Post only

3396* Piastra acciaio + tirafondi / Ground plate + concreting anchors

Idoneo all'installazione di 1/2 Triangolo grande in alluminio o 1/2 bracci orientabili. Assoluta assenza di parti in ferro. Completo trattamento di finitura anti UV e anticorrosione. Solo struttura, apparecchio Triangolo e bracci forniti a parte. Struttura interrabile mediante l'accessorio Classe II utilizzando apparecchi Triangolo in classe II

CE

Suitable to be installed with 1/2 Large Triangolo in aluminium or 1/2 adjustable arms. No steel part inside. UV and corrosion resistant finish. Post only, Triangolo fittings and arms are supplied separately. Post to be interred through the accessory. Class II using Triangolo fittings in class II

CE

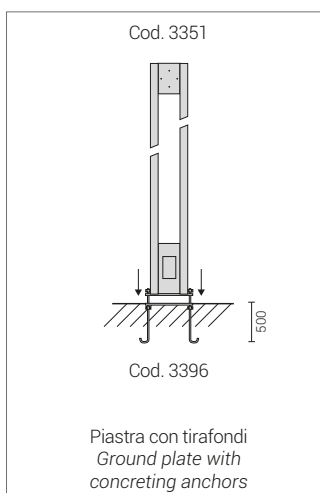

BRACCIO | ARM

Code + Colour

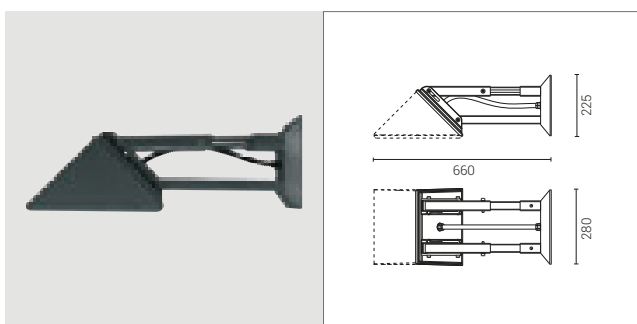

CODE DESCRIZIONE / DESCRIPTION GR

3322* Braccio orientabile per Triangolo Grande in alluminio
Adjustable arm for Large Triangolo in aluminium

Struttura in alluminio e acciaio. Viti inox. Adatto ad alloggiare un Triangolo Grande in alluminio con griglia, o a lente di Fresnel/Diamond. Orientabile da 0° a 45°. Completo di guaina passaggio cavi IP66. Solo braccio, apparecchio Triangolo fornito a parte. Classe II utilizzando apparecchi Triangolo in classe II

CE

Arm completely in aluminium. Stainless steel screws. Suitable to be installed on large Triangolo in aluminium with guard or with Diamond/Fresnel lens. Adjustable from 0° to 45°. Flexible waterproof conduit. Arm only, Triangolo fitting is supplied separately. Class II using Triangolo fittings in class II

CE

TRIANGOLO CITY



TRIANGOLO CITY CORRIDOR

Code + Colour

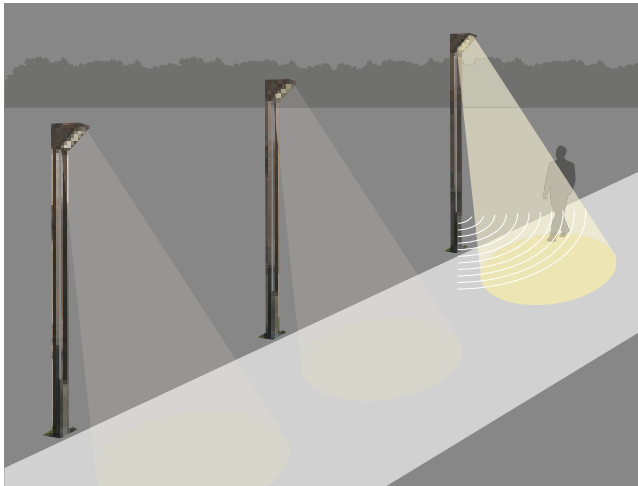

Con **Triangolo City Corridor** il risparmio energetico sposa l'architettura di arredo urbano. Grazie al particolare circuito incorporato, dotato di rilevatore di presenza, in condizioni di riposo la lampada emette il 10-20-30% di luminosità. Se una persona o una vettura entrano nel campo del sensore, la lampada viene automaticamente riportata alla massima luminosità per un tempo regolabile.

With **Triangolo City Corridor** the energy saving meets the public architectural environments. Thanks to a pir sensor settled on the base of the pole, compatible with the control gear incorporated in the luminaries, the systems gives 10-20-30% of the light available, but when somebody enters in the area the light comes on the maximum value. The pir sensor offers three regulations: area detection, daylight and switching time. Pir Sensor and control gear of the luminaries are compatible.

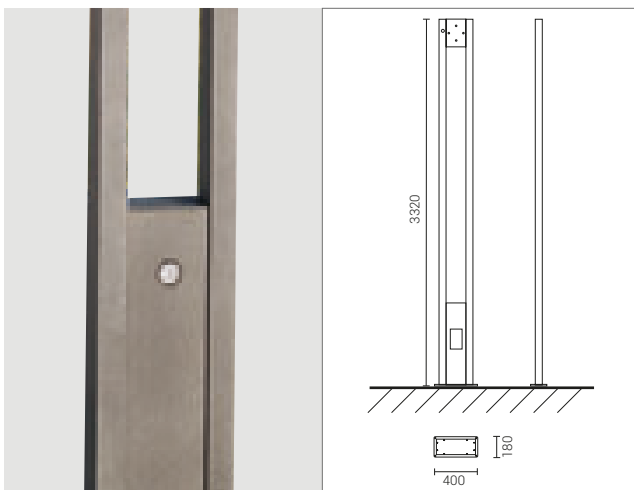

CODE DESCRIZIONE / DESCRIPTION

GR

3353* Palo completo di rilevatore di presenza
Post complete with pir sensor

Struttura: vedi cod. 3351.
Completo di rilevatore di presenza incassato nella struttura.
Tre regolazioni: livello lux di funzionamento, area di rilevamento, temporizzazione.
Comanda uno o due apparecchi Triangolo con reattore Corridor.
L'apparecchio Triangolo abbinato deve riportare la sigla COR a lato del codice.
IP 65 / Classe II
CE

Structure: see code 3351.
Complete of pir sensor recessed in the base.
Three regulations: area, daylight, timing.
The pir sensor can switch on the Corridor function in the luminaries Triangolo.
Add "COR" to the code of Triangolo fittings when working as Corridor function.
IP 65 / Class II
CE





WASH

EFFETTI A PARETE WALL EFFECT

Geometrie essenziali, luce indiretta, spiccata personalità, queste sono le credenziali con le quali si presenta la Serie WASH. Lampade da parete proposte con due geometrie, totalmente rettangolare o con profilo parabolico, tutte disponibili con doppia luce contrapposta o con luce singola, orientabili verso l'alto o verso il basso, grazie ai vetri fresati a filo scocca che impediscono i ristagni d'acqua. Due vetri diversi: opale per illuminazione diffusa; trasparente ultrawhite per luce più diretta con parabole asimmetriche riposizionabili per avvicinare o allontanare la luce dalla parete orientandola verso percorsi, viali, accessi. Le sorgenti luminose a Led sono di ultima generazione di grande efficienza e di lunga durata.

Basic shapes, indirect illumination, distinctive: all this you can find in the Goccia WASH Range. The range comes in two different shapes, a totally rectangular and a Parabolic profile. Both are available with single Led light up or down or double Led light. A version with Opal glass and Linear Led Modules gives a soft and comfortable spread of light and another version with clear glass and a single power Led gives a strong and asymmetric distribution of light. Thanks to the milled ultrawhite glass the top is completely flat to avoid water collection. With Lumen Outputs of 1120, 1200 and 1470 respectively each of these new generation Led fittings, both Linear and Power Led give the best in terms of light output and efficiency.





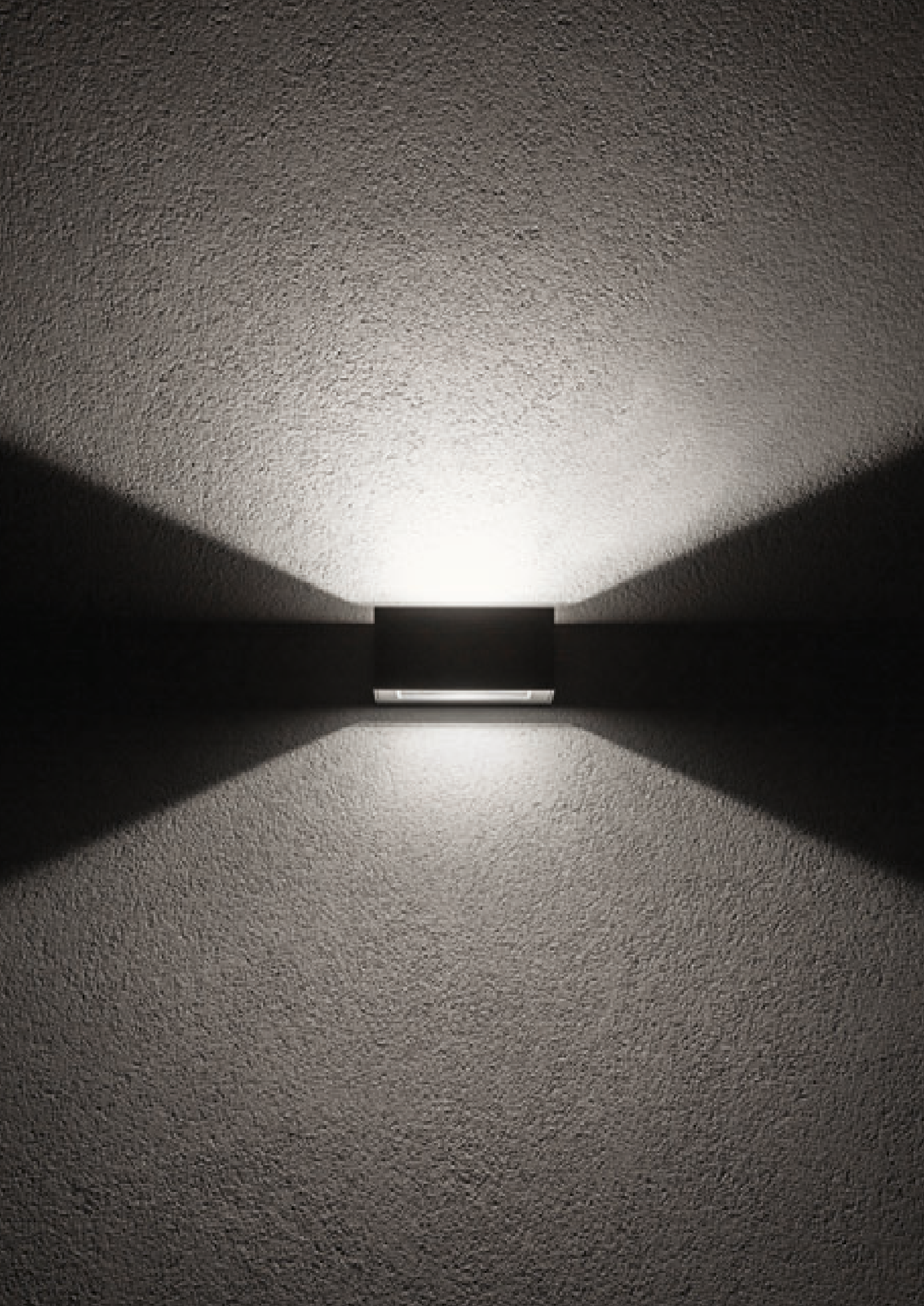

WASH

Effetti a parete
Wall effect

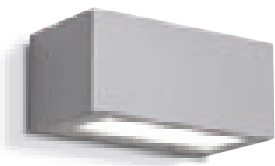

WASH 22

LED



WASH 42

LED

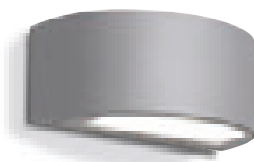

WASH 24

LED



WASH 52

LED

WASH RETTANGOLARE | WASH RECTANGULAR

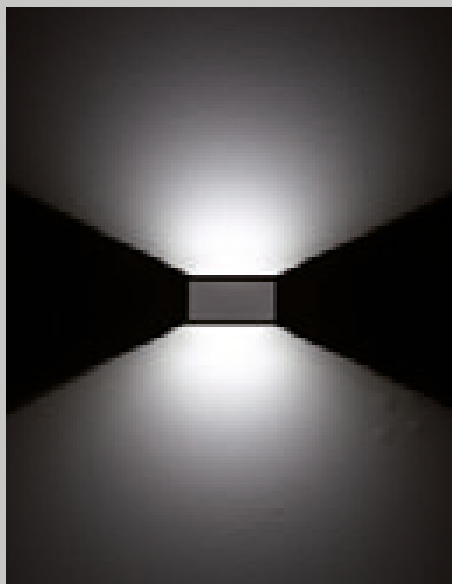

Parabola asimmetrica

Vetro trasparente con power Led - WASH 22

Asymmetric reflector

Ultra-white clear glass + Power Led - WASH 22

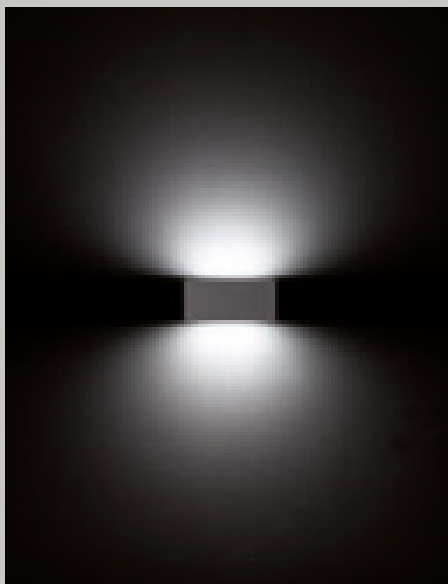

Vetro opale con modulo lineare Led - WASH 22

Opal glass + Linear Led Module - WASH 22

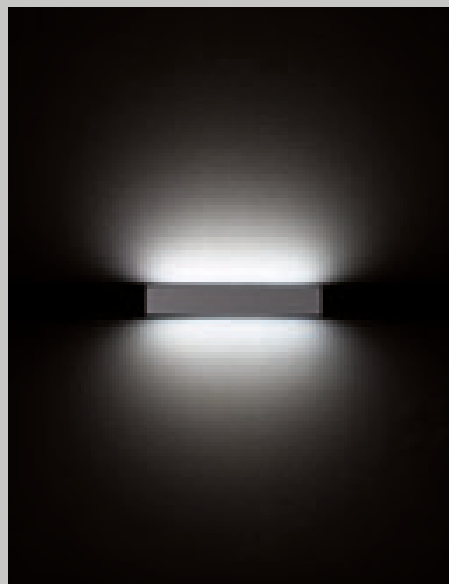

Vetro opale con modulo lineare Led - WASH 42

Opal glass + Linear Led Module - WASH 42

WASH PARABOLICA | WASH PARABOLIC

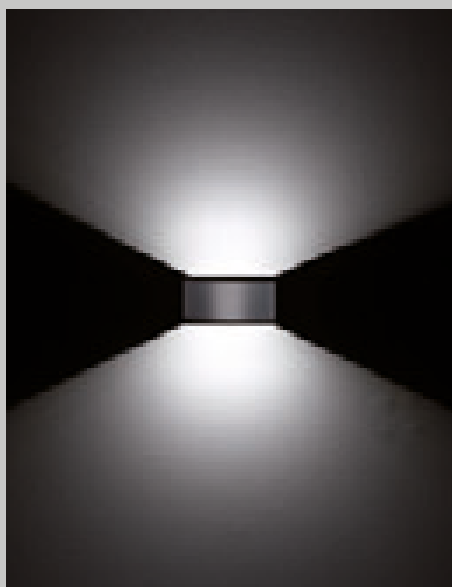

Parabola asimmetrica

Vetro trasparente con power Led - WASH 24

Asymmetric reflector

Ultra-white clear glass + Power Led - WASH 24

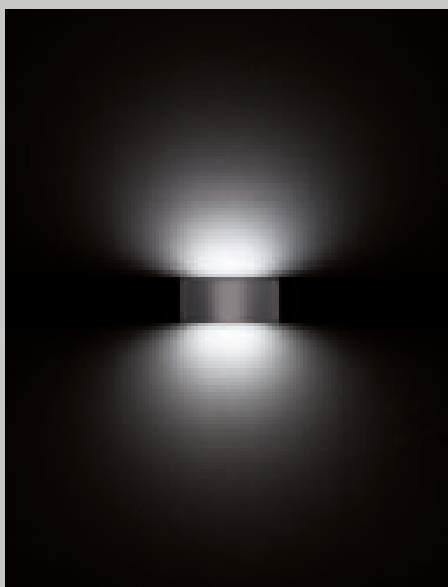

Vetro opale con modulo lineare Led - WASH 24

Opal glass + Linear Led Module - WASH 24

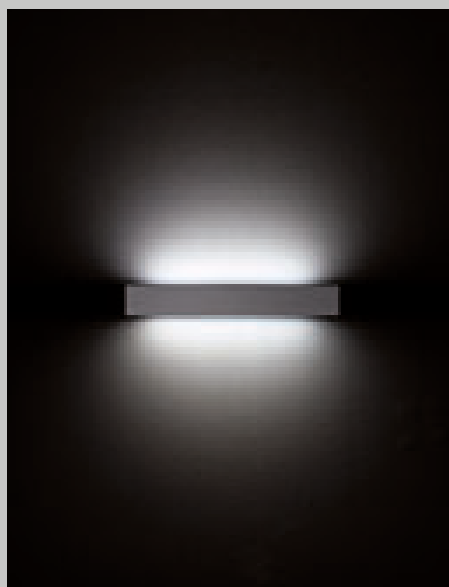

Vetro opale con modulo lineare Led - WASH 52

Opal glass + Linear Led Module - WASH 52

WASH

Effetti a parete
Wall effect

CARATTERISTICHE GENERALI

- Apparecchio da parete per esterno ad effetto wall-washer.
- **Struttura:** diffusore in vetro temprato opale o trasparente ultrawhite. Corpo in alluminio pressofuso a basso tenore di rame. Viti inox in tinta.
- Disponibile con doppia luce contrapposta e luce singola orientabile verso l'alto o verso il basso.
- Versione con emissione asimmetrica e vetro trasparente con demarcazione netta della luce. Versione con emissione luminosa simmetrica e vetro opale.
- **Sorgenti** a basso consumo e a **Led di nuova generazione** con vita garantita 60.000 h con successivo scadimento max del 20%. Driver incorporato.
- Ingresso cavi dal retro.
- **Finitura:** su alluminio, decappaggio + fosfocromatazione + fondo epossidico + verniciatura con polveri epossidiche stabilizzate anti UV.
- Costruito in conformità alle norme europee EN 60598-1:2015 **CE**

GENERAL FEATURES

- *Outdoor wall-washer effect wall fitting.*
- **Structure:** ultrawhite opal or transparent tempered glass diffuser. Low copper content die-cast aluminium body. Matching stainless steel screws.
- Available with double or single light that can be adjusted upward or downward.
- Version with asymmetric emission and clear glass with net light demarcation. Version with symmetrical light emission and opal glass.
- Low consumption **sources** and **new generation LEDs** with minimum life 60,000 h with subsequent deterioration max 20%. Driver inside.
- Cable entry from the back.
- **Finish:** on aluminium, pickling + phosphochrome + epoxy basic coating + UV resistant stabilised epoxy powder coating.
- Manufactured in compliance with European standards EN 60598-1:2015 **CE**

VETRO OPALE CON MODULO LINEARE LED

WASH è disponibile con vetri opale fresati per ottenere una luce diffusa e morbida.

OPAL GLASS, LINEAR MODULE FOR A SOFT LIGHT

WASH: Opal glass to have a soft and comfortable light.

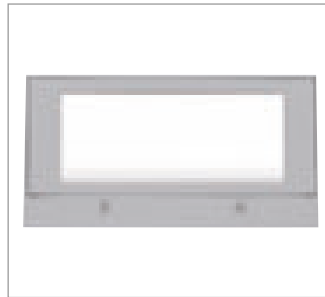

VETRO TRASPARENTE CON POWER LED

La versione con i vetri trasparenti ultrawhite e con le parabole asimmetriche riposizionabili emette una luce diretta, nitida e incisiva.

CLEAR GLASS + POWER LED FOR DIRECT LIGHT

Ultra-white clear glass and adjustable Asymmetric reflectors for a direct, sharp and incisive light.



PARABOLE ASIMMETRICHE RIPOSIZIONABILI

La versione con vetri trasparenti è fornita con una o due parabole asimmetriche che possono essere riposizionate per orientare la luce verso la parete (A), accentuando l'effetto wall-washer, o verso l'esterno (B) per illuminare i camminamenti.

ADJUSTABLE ASYMMETRIC REFLECTORS

The Asymmetric reflector can be fixed in two different positions: against the wall to highlight the wall-washer effect or adjusted to illuminate balconies, walkways, corridors etc.

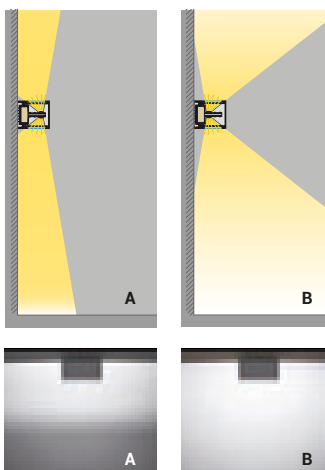

RIPOSIZIONAMENTO SEMPLICISSIMO

La variazione della posizione delle parabole è semplice e agevole e può essere effettuata anche ad apparecchio installato. Sollevare la parabola e ruotarla di 180°, poi riposizionarla nella sua sede

SIMPLE REFLECTOR ADJUSTMENT

It is quite simple to adjust the reflector: adjustment can be made even if the light is on. Unscrew, lift the reflector, turn 180° and screw.



WASH

Effetti a parete
Wall effect



WASH 22

Code + Colour + Tonality

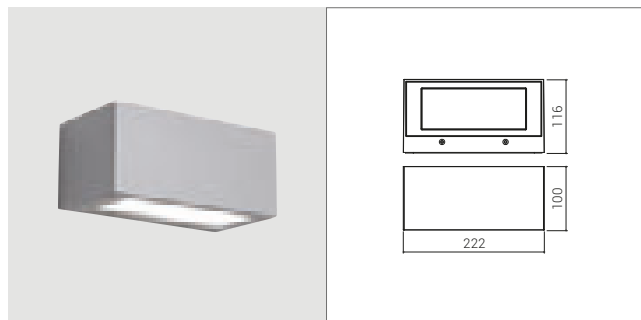

CODE LAMP W Im Nominali - Real output **GR** **GM** **BI**

Bifacciale - Up + down light

1301* Led 2X9,3 2X1120 1394

1302* E 27 Dulux El L max 176mm 18

Monofacciale - Single light (up or down)

1305* Led 1X9,3 1120 513

1306* E 27 Dulux El L max 176mm 18

Struttura in alluminio pressofuso in lega marina.

Vetro opale fresato a livello del bordo.

IP 65 / Classe I / IK 08

CRI 80 / Driver IN / 500 mA

230V / 50 Hz

Dimmerabile a richiesta. Emergenza a richiesta.

Tonalità 3000K o 4000K. Aggiungere 3K o 4K al codice dopo il colore.

Marine die-cast aluminium alloy housing. Milled opal glass - frame level.

IP 65 / Class I / IK 08

CRI 80 / Driver IN / 500 mA

230V / 50 Hz

Dimmable on request. Emergency on request.

Color temperature available 3000K or 4000K. Add 3K or 4K to the code after the color.

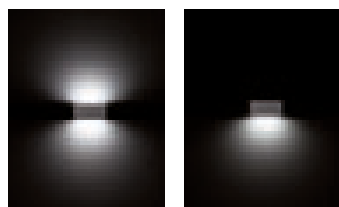

Vetro opale con modulo lineare Led
Opal glass + Linear Led Module

Code + Colour + Tonality

CODE LAMP W Im Nominali - Real output **GR** **GM** **BI**

Bifacciale - Up + down light

1308* Led 2x9,5 2x1200 1860

Monofacciale - Single light (up or down)

1309* Led 1x9,5 1x1200 930

Vetro ultrawhite trasparente fresato a livello del bordo.

Parabola asimmetrica con doppia

posizione.

IP 65 / Classe I / IK 08

CRI 80 / Driver IN / 350 mA

230V / 50 Hz

Tonalità 3000K o 4000K. Aggiungere 3K o 4K al codice dopo il colore.

Ultra-white milled clear glass-frame level. Asymmetric reflector suitable to double

position.

IP 65 / Class I / IK 08

CRI 80 / Driver IN / 350 mA

230V / 50 Hz

Color temperature available 3000K or 4000K. Add 3K or 4K to the code after the color.

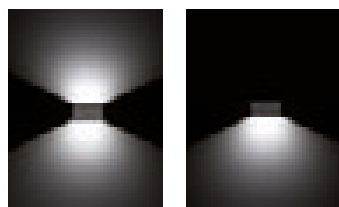

Vetro trasparente con parabola
asimmetrica e power Led
Ultra-white clear glass +
asymmetric reflector and Power
Led

WASH 42

Code + Colour + Tonality

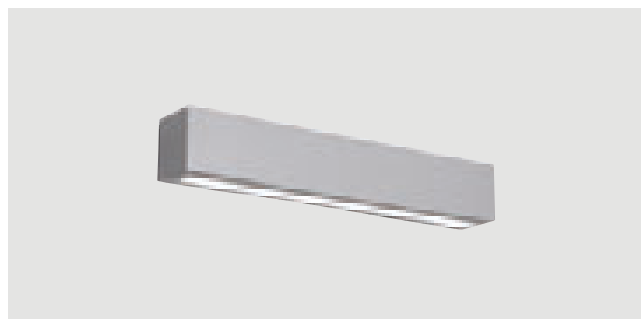

CODE LAMP W Im Nominali - Real output **GR** **GM** **BI**

Bifacciale - Up + down light

1311* Led 2x11 2x1470 1280

Monofacciale - Single light (up or down)

1312* Led 11 1470 640

Vetro opale fresato a livello del bordo.

IP 65 / Classe I / IK 08

CRI 80 / Driver IN / 700 mA

230V / 50 Hz

Dimmerabile a richiesta. Emergenza a richiesta.

Tonalità 3000K o 4000K. Aggiungere 3K o 4K al codice dopo il colore.

Milled Opal glass - frame level.

IP 65 / Class I / IK 08

CRI 80 / Driver IN / 700 mA

230V / 50 Hz

Dimmable on request. Emergency on request.

Color temperature available 3000K or 4000K. Add 3K or 4K to the code after the color.

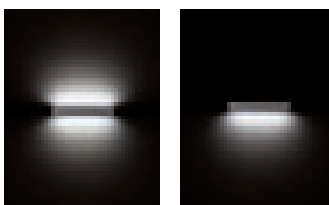

Vetro opale con modulo lineare Led
Opal glass + Linear Led Module

WASH



WASH 24

Code + Colour + Tonality

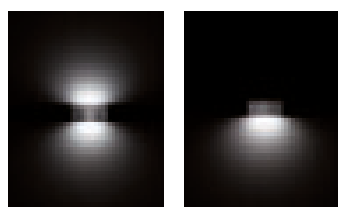
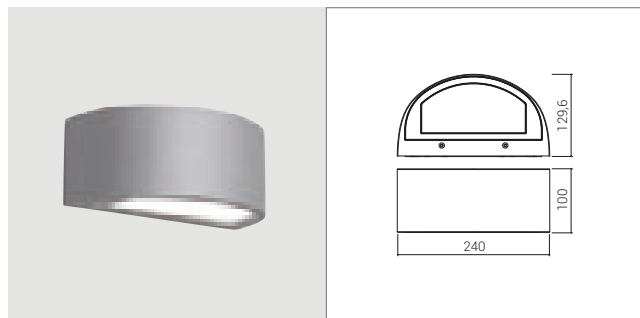

Vetro opale con modulo lineare Led
Opal glass + Linear Led Module

CODE	LAMP	W	Im Nominali - Real output	GR	GM	BI
------	------	---	---------------------------	----	----	----

Bifacciale - Up + down light

1321* Led 2X9,3 2X1120 1394

1322* E 27 Dulux El L max 176mm 18

Monofacciale - Single light (up or down)

1324* Led 1X9,3 1120 513

1325* E 27 Dulux El L max 176mm 18

Struttura in alluminio pressofuso in lega marina.

Vetro opale fresato a livello del bordo.

IP 65 \blacklozenge \blacktriangle \blacktriangle / Classe I / IK 08

CRI 80 / Driver IN / 500 mA

230V / 50 Hz CE

Dimmerabile a richiesta. Emergenza a richiesta.

Tonalità 3000K o 4000K. Aggiungere 3K o 4K al codice dopo il colore.

Marine die-cast aluminium alloy housing. Milled opal glass - frame level.

IP 65 \blacklozenge \blacktriangle \blacktriangle / Class I / IK 08

CRI 80 / Driver IN / 500 mA

230V / 50 Hz CE

Dimmable on request. Emergency on request.

Color temperature available 3000K or 4000K. Add 3K or 4K to the code after the color.

Code + Colour + Tonality

CODE	LAMP	W	Im Nominali - Real output	GR	GM	BI
------	------	---	---------------------------	----	----	----

Bifacciale - Up + down light

1327* O Led 2x9,5 2x1200 1860

Monofacciale - Single light (up or down)

1328* O Led 1X9,5 1x1200 930

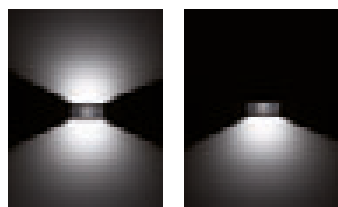

Vetro trasparente con parabola asimmetrica e power Led
Ultra-white clear glass + asymmetric reflector and Power Led

Vetro ultrawhite trasparente fresato a livello del bordo.

Parabola asimmetrica con doppia posizione.

IP 65 \blacklozenge \blacktriangle \blacktriangle / Classe I / IK 08

CRI 80 / Driver IN / 350 mA

230V / 50 Hz CE

Tonalità 3000K o 4000K. Aggiungere 3K o 4K al codice dopo il colore.

Ultra-white milled clear glass-frame level. Asymmetric reflector suitable to double position.

IP 65 \blacklozenge \blacktriangle \blacktriangle / Class I / IK 08

CRI 80 / Driver IN / 350 mA

230V / 50 Hz CE

Color temperature available 3000K or 4000K. Add 3K or 4K to the code after the color.

WASH 52

Code + Colour + Tonality

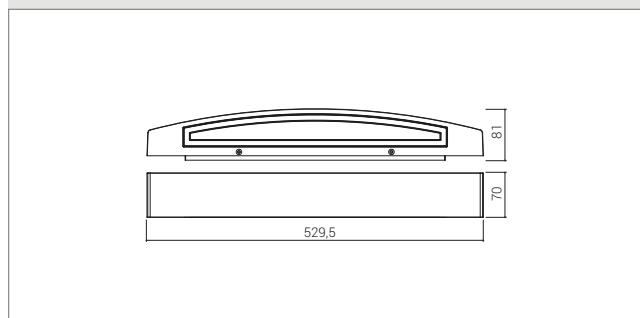

CODE	LAMP	W	Im Nominali - Real output	GR	GM	BI
------	------	---	---------------------------	----	----	----

Bifacciale - Up + down light

1332* Led 2x11 2x1470 1394

Monofacciale - Single light (up or down)

1333* Led 11 1470 698

Vetro opale fresato a livello del bordo.

IP 65 \blacklozenge \blacktriangle \blacktriangle / Classe I / IK 08

CRI 80 / Driver IN / 700 mA

230V / 50 Hz CE

Dimmerabile a richiesta. Emergenza a richiesta.

Tonalità 3000K o 4000K. Aggiungere 3K o 4K al codice dopo il colore.

Milled Opal glass - frame level.

IP 65 \blacklozenge \blacktriangle \blacktriangle / Class I / IK 08

CRI 80 / Driver IN / 700 mA

230V / 50 Hz CE

Dimmable on request. Emergency on request.

Color temperature available 3000K or 4000K. Add 3K or 4K to the code after the color.

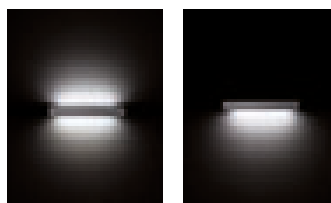

Vetro opale con modulo lineare Led
Opal glass + Linear Led Module



SERIE K³

EFFETTI A PARETE WALL EFFECT

Una forma elementare, il cubo, veste un'idea innovativa: l'illuminazione creativa. La Serie K³ di Goccia Illuminazione è nata per consentire la massima libertà nel dipingere sulle pareti giochi di luce e colore. Tre diverse interpretazioni di un'unica filosofia, tre diversi apparecchi (a 1, 2 e 4 finestre) con una grande semplicità di installazione:

K³ WRITER: tre scocche con lenti concentranti, schermi sagomatori e filtri colorati, tutti intercambiabili, permettono di creare infiniti effetti luminosi per sottolineare le architetture. Tre sorgenti luminose tutte ad alta intensità: ioduri metallici da 20 e 35 W, Led di potenza di ultima generazione.

K³ MINILED: tutta la magia dei Led di potenza in un piccolo cubo luminoso. Estremamente compatto, grazie alle lenti di diffusione a filo cornice, può essere installato con qualsiasi orientamento e su ogni superficie, anche in interni, per donare il tocco finale ad ogni ambiente.

K³ POWER: il cubo racchiude una nuova potenza luminosa. Grazie ad un accurato studio ottico delle parabole, garantisce un rendimento luminoso che supera il 69%. Previsto con 4 potenti sorgenti luminose consente di risolvere ogni possibile illuminazione in esterni su architetture private o di arredo urbano.

A minimalist shape containing an innovative idea: creative lighting. The K³ series by Goccia Illuminazione has been created to allow maximum creative freedom, coating walls with light and colour. Three different interpretations of a single philosophy, three different fittings (with 1, 2, and 4 windows) with exceptionally easy installation:

K³ WRITER: three bodies with converging lenses, thin masks and coloured filters. All interchangeable to create infinite lighting effects to emphasise the architecture. Three high-intensity light sources: 20 and 35 W metal Halide, the latest generation of power LEDs.

K³ MINILED: all the magic of power LEDs in a small lit cube. Extremely compact, thanks to its flush diffuser lenses, can be installed in any direction and on any surface, including indoors, to give a finishing touch to any area.

K³ POWER: the cubic shape contains a new lighting power. Thanks to a careful optical study of parabolic reflectors, these ensure light efficiency of over 69%. Set with 4 powerful light sources for all types of outdoor lighting in private or public architecture.





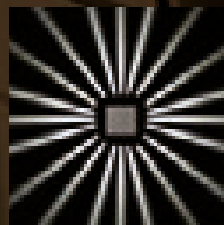
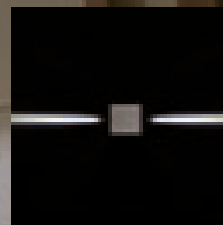
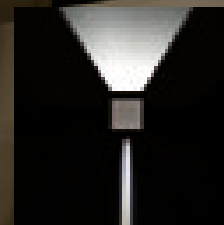
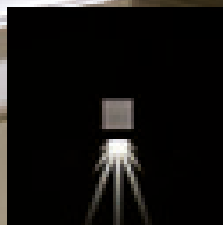
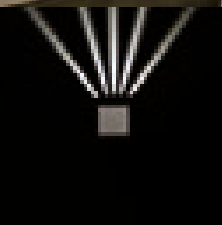

K³ WRITER

Effetti a parete
Wall effect

Alluminio - Aluminium



Una apertura
One window

LED



Due aperture
Two windows

LED

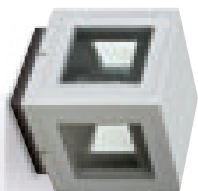

Quattro aperture
Four windows

LED

Inox AISI 316L - AISI 316L Stainless steel



Una apertura
One window

LED



Due aperture
Two windows

LED

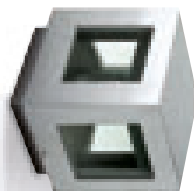

Quattro aperture
Four windows

LED

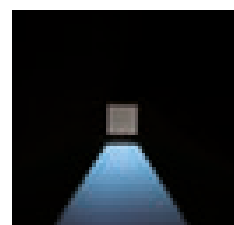
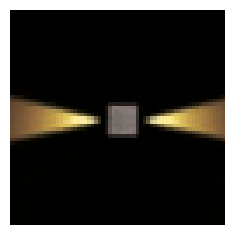
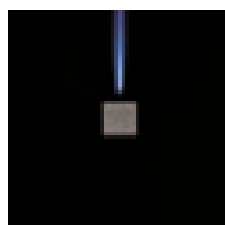
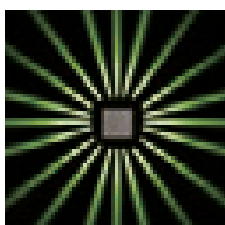
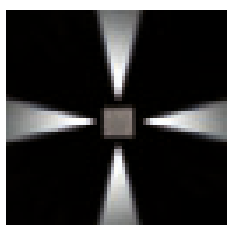
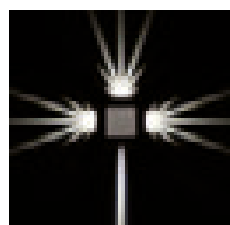



K³ WRITER

Effetti a parete
Wall effect

CARATTERISTICHE GENERALI

- Apparecchio per esterno di forma cubica, per effetti a parete.
- **Struttura:** diffusore in vetro temprato ultrawhite. Corpo in alluminio pressofuso a basso tenore di rame o in inox AISI 316L. Viti inox a brugola in tinta. Interno interamente nero opaco per evitare fastidiose riflessioni luminose.
- Lenti ottiche e schermi dedicati da inserire in ogni finestra per ottenere effetti speciali.
- Installabile a parete/soffitto ed a terra in giardino con apposito picchetto.
- La sorgente Led è orientata di 10° verso la parete per accentuare l'effetto wall-washer.
- Ingresso cavi dal retro.
- **Sorgenti luminose** a basso consumo o **Led di nuova generazione** con vita garantita 60.000 h con successivo scadimento max del 20%. Driver incorporato.
- **Finitura:** per alluminio, decappaggio + fosfocromatazione + fondo epossidico + verniciatura con polveri epossidiche stabilizzate anti UV. Per inox: spazzolato e lucidato.
- Costruito in conformità alle norme europee EN 60598-1:2015 CE

CREATIVITÀ ILLIMITATA

La Serie K³ Writer comprende 3 apparecchi base con diffusione della luce a 70°. Sono totalmente stagni, pertanto possono essere orientati in ogni direzione e su ogni superficie (muro, pavimento, soffitto).

- 1 - Cubo con una finestra, orientabile in ogni direzione.
- 2 - Cubo con due finestre contrapposte, orientabili alto/basso, destra/sinistra o 45°.
- 3 - Cubo con quattro finestre.

UNLIMITED CREATIVITY

K³ Writer consists of three basic cubes with 70° angle beam light diffusion. Are completely waterproof: it means you can orient fixture and light towards any direction and install in any position - wall, floor, ceiling.

- 1 - Cube with one window. Suitable to any light direction.
- 2 - Cube with two opposite windows. To be oriented towards up/down, left/right or 45°.
- 3 - Cube with 4 windows.

MATERIALI E COLORI

Gli apparecchi sono disponibili in alluminio grigio (1), alluminio bianco (2), alluminio grafite (3) e in acciaio inox AISI 316L (4).

MATERIALS AND COLOURS

The lighting fittings are available in primary aluminium, finished in light grey (1), matt white (2) and graphite (3), and in AISI 316L stainless steel (4).

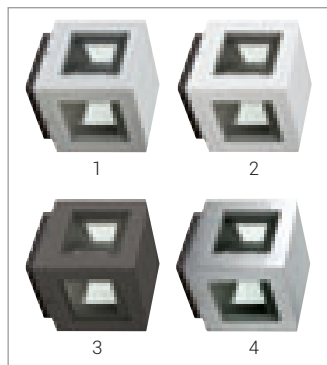
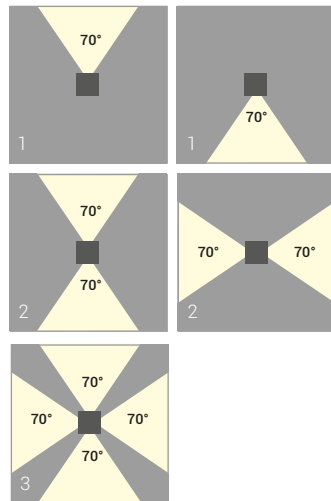

GENERAL FEATURES

- Cubic form fitting for wall effects.
- **Structure:** ultrawhite transparent tempered glass diffuser. Low copper content die-cast aluminium or AISI 316L stainless steel body. Matching stainless steel Allen screws. Completely matt black to avoid any unwanted flare.
- Optical lenses and special masks to be inserted on each window for special effects.
- Can be installed on wall/ceiling and in the ground in the garden using a special spike.
- The LED source is directed 10° toward the wall to accentuate the wall-washer effect.
- Cable entry from the back.
- Low consumption **light sources** or **new generation LEDs** with minimum life 60,000 h with subsequent deterioration max 20%. Driver inside.
- **Finish:** for aluminium, pickling + phosphochrome + epoxy basic coating + UV resistant stabilised epoxy powder coating. For stainless steel: brushed and polished.
- Manufactured in compliance with European standards EN 60598-1:2015 CE

MONTAGGIO SEMPLIFICATO

Lo smontaggio è agevole anche con l'apparecchio installato. L'interno è studiato per garantire la massima efficienza luminosa e il perfetto puntamento della luce.

EASY INSTALLATION

Disassembly is easy even with the fitting installed. The inside has been studied to ensure maximum lighting efficiency and perfect light direction.



CENTRAGGIO DELLA FOCALE

L'installazione delle lenti e degli schermi sagomatori è semplicissima: le 4 viti su asola consentono il centraggio dell'accessorio e della sua focale.

CENTRING FOCUS

Lens and masks can be easily inserted: 4 screws and its oval buttonholes permit a complete and perfect focus regulation.



INFINITE COMBINAZIONI

Inserendo i 4 schermi si ottengono infinite combinazioni:

- due lenti concentratrici in vetro a 1 o 5 lame, progettate per ottenere effetti di alta intensità
- due schermi sagomati
- 4 filtri cromatici permettono di arricchire gli effetti luminosi con il colore.

INFINITE COMBINATIONS

The 4 screens permit infinity combinations:

- two converging lenses in borosilicate glass for 1 or 5 blades designed to enhance its lighting effects
- two thin masks (gobos)
- 4 dichroic color filters



K³ WRITER

Effetti a parete
Wall effect



K³ WRITER ALLUMINIO | K³ WRITER ALUMINIUM

Code + Colour + Tonality

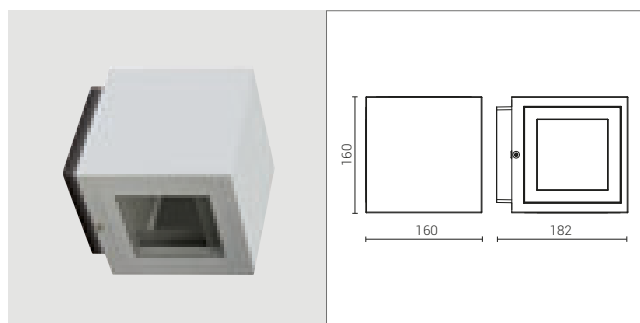

1 faccia aperta | 1 window

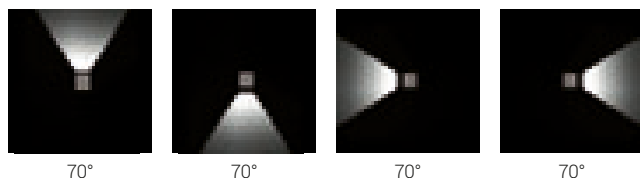

CODE	LAMP	W	lm Nominali-Real output	GR	GM	BI
1001*		GU 6,5	20			
1002*		GU 6,5	35			
1004*		Led	1x6,4	640	125	

Alimentazione 230V con reattore elettronico per 20 e 35W e driver 230V per led incorporati.
Colore Corten a richiesta.
Lampadine escluse per 20W e 35W Ioduri Metallici. Led incluso per cod. 1004.
IP 65 / Classe II / IK 08
CRI 85 / Driver IN / 700 mA
230V / 50 Hz
CE
Tonalità 3000K o 4000K. Aggiungere 3K o 4K al codice dopo il colore.

Electronic ballast inside for 20W and 35W metal halide.
Corten colour available upon request.
Without lamps for 20W and 35W metal halide. Led included for 1004.
IP 65 / Class II / IK 08
CRI 85 / Driver IN / 700 mA
230V / 50 Hz
CE
Color temperature available 3000K or 4000K. Add 3K or 4K to the code after the color.

Code + Colour + Tonality

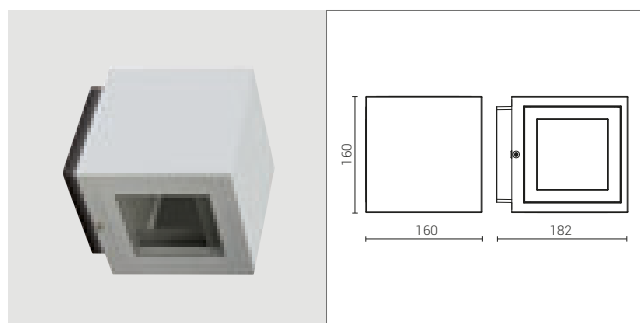

2 facce aperte | 2 windows

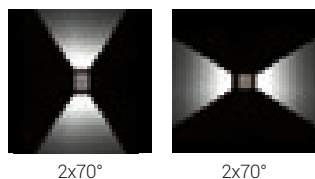

CODE	LAMP	W	lm Nominali-Real output	GR	GM	BI
1006*		GU 6,5	20			
1007*		GU 6,5	35			
1008*		Led	2x6,4	1280	250	

Lampadine escluse per 20W e 35W Ioduri Metallici. 2 Led inclusi per cod. 1008.

Without lamps for 20W and 35W metal halide. 2 Led included for 1008.

Code + Colour + Tonality

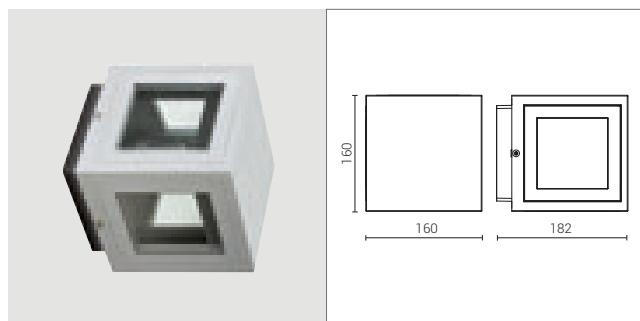

4 facce aperte | 4 windows

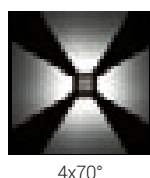

CODE	LAMP	W	lm Nominali-Real output	GR	GM	BI
1020*		GU 6,5	20			
1021*		GU 6,5	35			
1022*		Led	4x6,4	2560	500	

Lampadine escluse per 20W e 35W Ioduri Metallici. 4 Led inclusi per cod. 1022.

Without lamps for 20W and 35W metal halide. 4 Led included for 1022.



K³ WRITER INOX AISI 316L | K³ WRITER STAINLESS STEEL AISI 316L

Code + Colour + Tonality

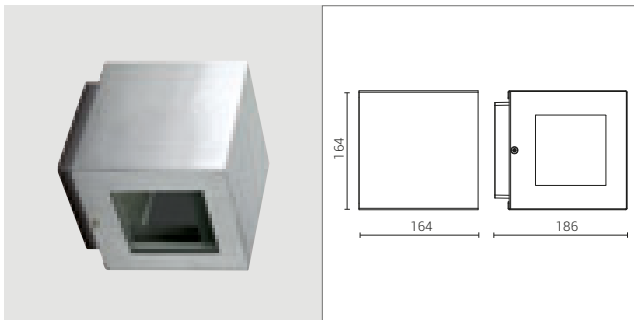

1 faccia aperta | 1 window

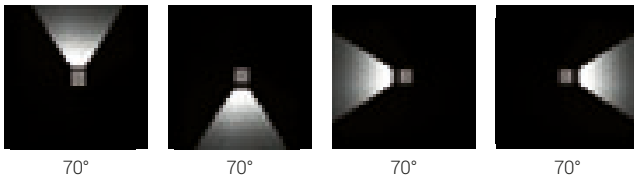

CODE	LAMP	W	lm Nominali-Real output	IN
1011*	GU 6,5	20		
1012*	GU 6,5	35		
1014*	Led	1x6,4	640 125	

Struttura esterna in inox AISI 316L.
Parte interna in alluminio.
Alimentazione 230V con reattore elettronico per 20 e 35W e driver 230V per led incorporati.
Lampadine escluse per 20W e 35W Ioduri Metallici. Led incluso per cod. 1014.
IP 65 / Classe II / IK 08
CRI 85 / Driver IN / 700 mA
230V / 50 Hz

€ €
Tonaltà 3000K o 4000K. Aggiungere 3K o 4K al codice dopo il colore.

*AISI 316L Stainless Steel structure.
Die-cast primary Aluminium inside.
Electronic ballast inside for 20W and 35W metal halide.
Without lamps for 20W and 35W metal halide. Led included for 1014.
IP 65 / Class II / IK 08
CRI 85 / Driver IN / 700 mA
230V / 50 Hz
€ €
Color temperature available 3000K or 4000K. Add 3K or 4K to the code after the color.*

Code + Colour + Tonality

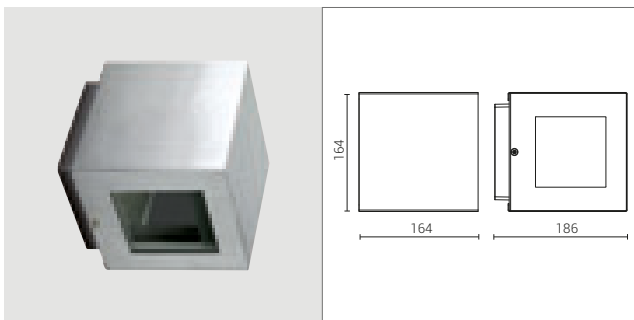

2 facce aperte | 2 windows

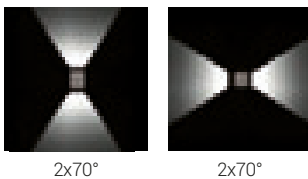

CODE	LAMP	W	lm Nominali-Real output	IN
1016*	GU 6,5	20		
1017*	GU 6,5	35		
1018*	Led	2x6,4	1280 250	

Lampadine escluse per 20W e 35W Ioduri Metallici. 2 Led inclusi per cod. 1018.

Without lamps for 20W and 35W metal halide. 2 Led included for 1018.

Code + Colour + Tonality

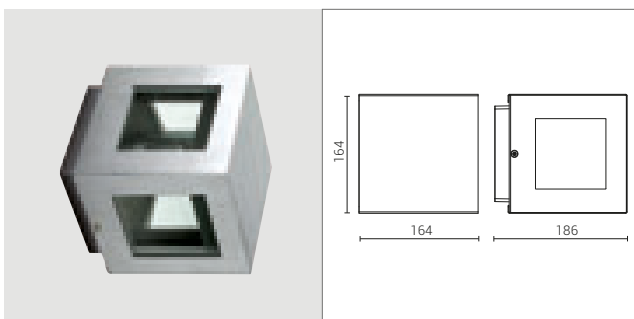

4 facce aperte | 4 windows

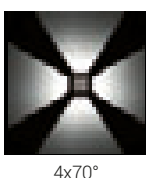

CODE	LAMP	W	lm Nominali-Real output	IN
1031*	GU 6,5	20		
1032*	GU 6,5	35		
1033*	Led	4x6,4	2560 500	

Lampadine escluse per 20W e 35W Ioduri Metallici. 4 Led inclusi per cod. 1033.

Without lamps for 20W and 35W metal halide. 4 Led included for 1033.

K³ WRITER

Effetti a parete
Wall effect

LENTI | LENS

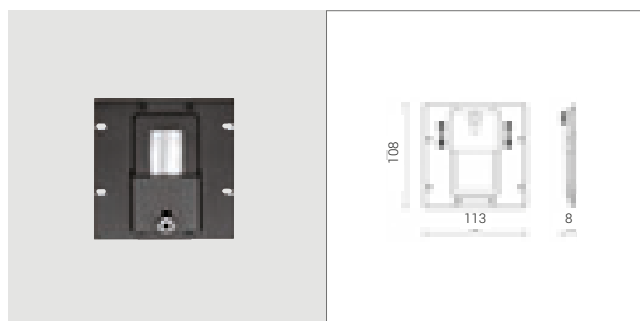

CODE DESCRIZIONE / DESCRIPTION

1091 Lente per lama 1 / Lens for 1 blade

Lente convergente in vetro in borosilicato purissimo.
Asole per regolazione laterale.
Completo di otturatore a saracinesca per accorciare la lama ove richiesto.
Telaio in acciaio. Colore telaio nero.

*Converging lens in pure borosilicate glass.
Screws/oval buttonholes connection for side regulation.
Adjustable plate to reduce the light length if necessary.
Black steel holding frame.*

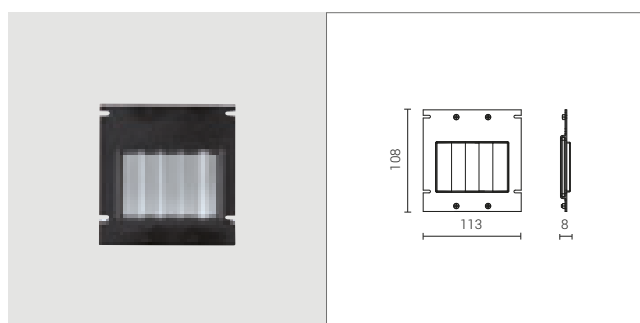
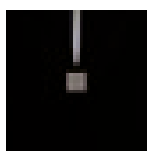

CODE DESCRIZIONE / DESCRIPTION

1092 Lente per lama 5 / Lens for 5 blades

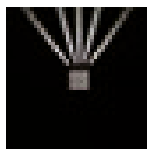

SCHERMO | THIN MASKS (GOBOS)

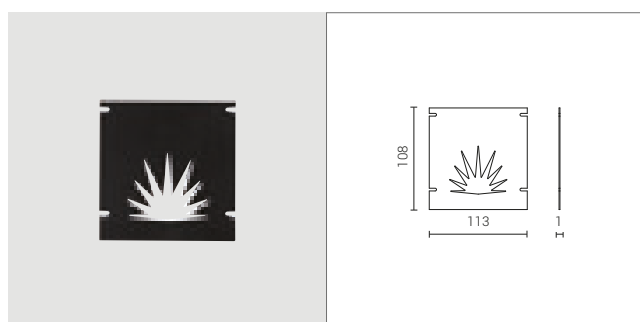

CODE DESCRIZIONE / DESCRIPTION

1093 Sagomatore a foglia / Leaf shape

Sagomatore in acciaio.
Colore nero.

*Thin steel masks to shape the light.
Color black.*

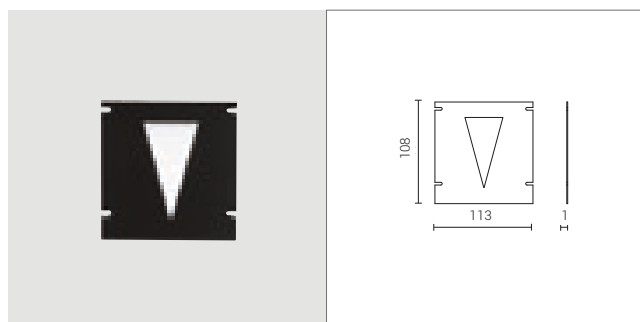
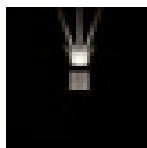

CODE DESCRIZIONE / DESCRIPTION

1095 Sagomatore 30° / 30° shape

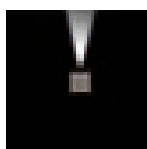

K³ WRITER

FILTRI COLORE | COLOR FILTERS

Code + Colour

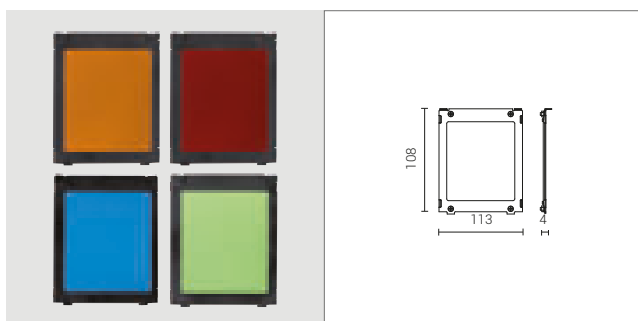

CODE DESCRIZIONE / DESCRIPTION

RO AR BL VE

1096* Filtro dicroico / Dichroic filter

Filtro colore con trattamento dicroico.
Vetro in borosilicato.
Telaio in acciaio nero.
1 filtro per 1 faccia.

*Dichroic finish.
Color and glass amalgam system.
Black steel frame.
1 filter for 1 window.*





K³ MINILED

Effetti a parete
Wall effect

Alluminio - Aluminium

Una apertura
One window

LED

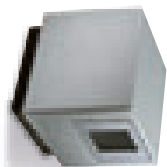

Due aperture
Two windows

LED

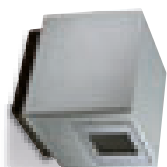

Quattro aperture
Four windows

LED

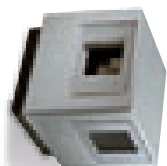

Inox AISI 316L - AISI 316L Stainless steel

Una apertura
One window

LED



Due aperture
Two windows

LED



Quattro aperture
Four windows

LED



COMBINAZIONI DEI FASCI LUMINOSI | ANGLE BEAM COMBINATIONS

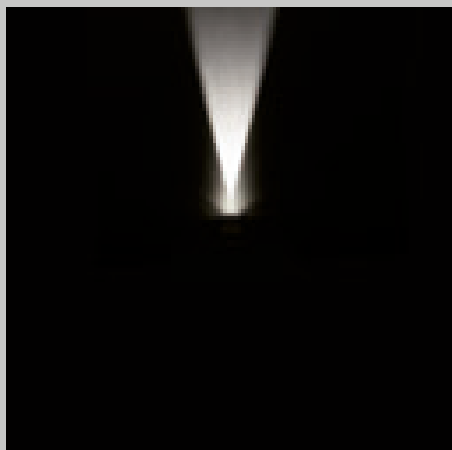

Un fascio 30°
30° one window

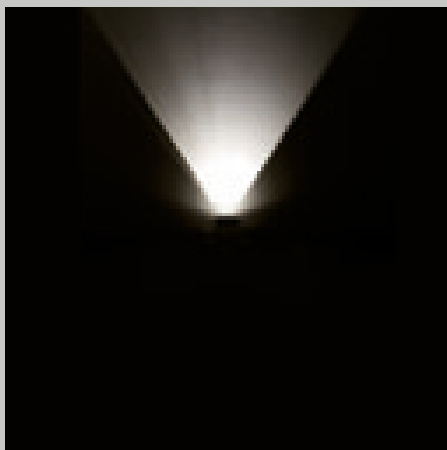

Un fascio 70°
70° one window

K³ Miniled è composta da 3 apparecchi

- cubo con una finestra
- cubo con due finestre contrapposte
- cubo con quattro finestre

Il fascio luminoso è disponibile in due diverse angolazioni:

- stretto, di 30°
- diffuso, di 70°

K³ Miniled range consists of 3 fixtures

- cube with one window
- cube with two opposite windows
- cube with 4 windows

Two angle beam available

- narrow 30°
- wide 70°

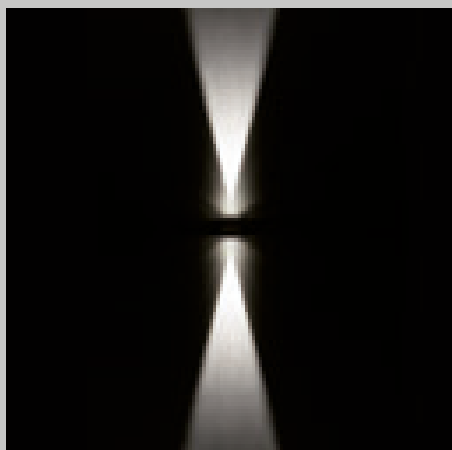

Due fasci 30°
30° two windows

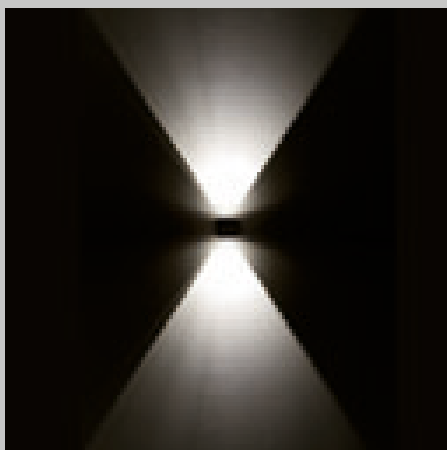

Due fasci 70°
70° two windows

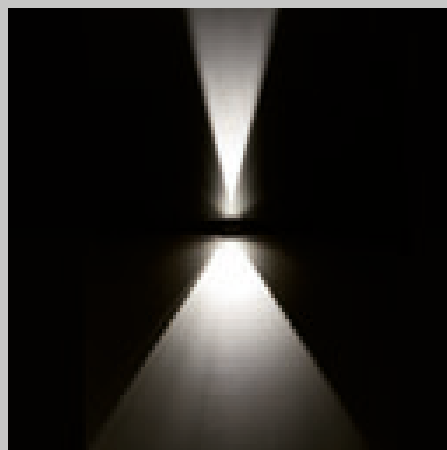

Un fascio 30° - Un fascio 70°
30°+70° two windows

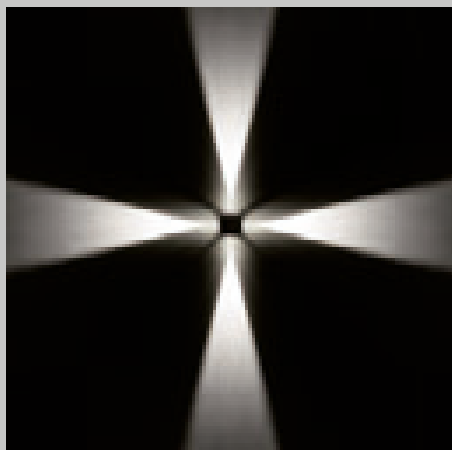

Quattro fasci 30°
30° four windows

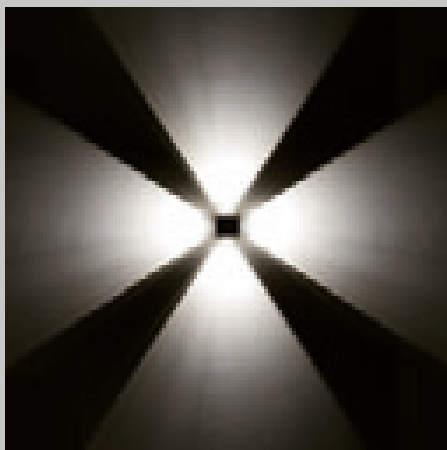

Quattro fasci 70°
70° four windows

K³ MINILED

Effetti a parete
Wall effect

CARATTERISTICHE GENERALI

- Apparecchio per esterno di forma cubica in dimensioni ridotte.
- **Struttura:** diffusore in policarbonato anti UV. Corpo in alluminio pressofuso a basso tenore di rame o in inox AISI 316L. Viti inox a brugola in tinta.
- Emissione luce con demarcazione netta della luce.
- Installabile a parete/soffitto ed a terra in giardino con apposito picchetto.
- Ingresso cavi dal retro.
- La sorgente Led è orientata di 10° verso la parete per accentuare l'effetto wall-washer.
- **Sorgenti** Led di nuova generazione con vita garantita 60.000 h con successivo scadimento max del 20%. Driver incorporato.
- **Finitura:** per alluminio, decappaggio + fosfocromatazione + fondo epossidico + verniciatura con polveri epossidiche stabilizzate anti UV. Per inox: spazzolato e lucidato.
- Costruito in conformità alle norme europee EN 60598-1:2015 **CE**

GENERAL FEATURES

- *Small size, cubic form outdoor fitting.*
- **Structure:** polycarbonate UV resistant diffuser. Low copper content die-cast aluminium or AISI 316L stainless steel body. Matching stainless steel Allen screws.
- *Light emissions with net light demarcation.*
- *Can be installed on wall/ceiling and in the ground in the garden using a special spike.*
- *Cable entry from the back.*
- *The LED source is directed 10° toward the wall to accentuate the wall-washer effect.*
- *New generation LED sources with minimum life 60,000 h with subsequent deterioration max 20%. Driver inside.*
- **Finish:** for aluminium, pickling + phosphochrome + epoxy basic coating + UV resistant stabilised epoxy powder coating. For stainless steel: brushed and polished.
- *Manufactured in compliance with European standards EN 60598-1:2015 **CE***

MATERIALI E COLORI

Gli apparecchi sono disponibili in alluminio grigio (1), alluminio bianco (2), alluminio grafite (3) e in acciaio inox AISI 316L (4).

MATERIALS AND COLOURS

The lighting fittings are available in primary aluminium, finished in light grey (1), matt white (2) and graphite (3), and in AISI 316L stainless steel (4).



EFFICIENZA LUMINOSA

L'efficienza luminosa è assicurata dall'alta resa del led di potenza: 3 W con 185 lumen per faccia. Le lenti sono appositamente progettate per ottimizzare la diffusione della luce. Il corpo lampada contiene il driver per l'alimentazione a 230V.

LIGHTING EFFICIENCY

High efficiency power leds: 1/2/4 units with 3W and 185 lumen each. Special pure lens govern and direct the light and its angle beam. 220-250V 50-60Hz driver inside.



SMONTAGGIO SEMPLIFICATO

Lo smontaggio è semplificato ed è agevole anche con l'apparecchio installato. I diffusori in policarbonato sono a filo cornice onde evitare ristagni d'acqua.

EASY DISASSEMBLY

Assembling and maintenance are simple even if the fixture is already installed. The polycarbonate diffusers at frame level avoid stagnant water on the up surface.

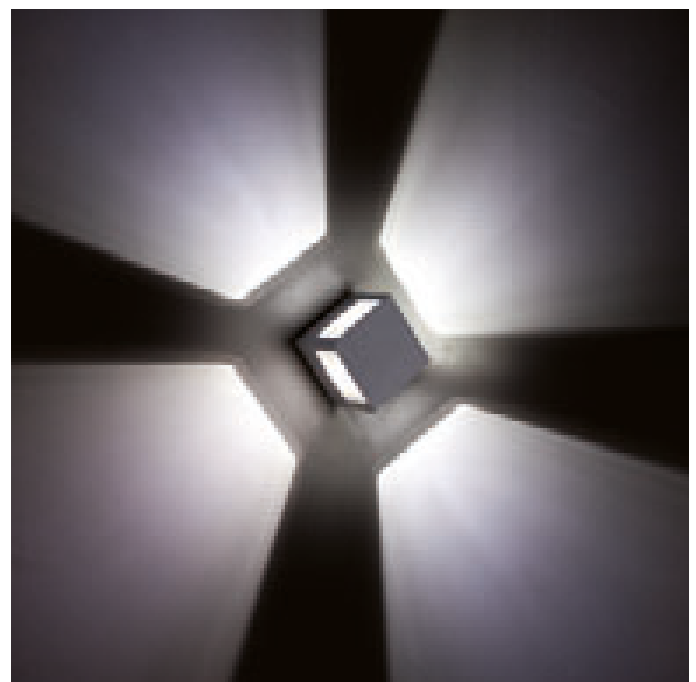
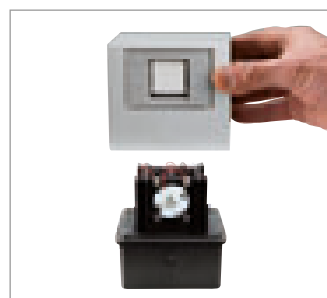

K³ MINILED

Effetti a parete
Wall effect



K³ MINILED ALLUMINIO | K³ MINILED ALUMINIUM

Code + Colour + Tonality

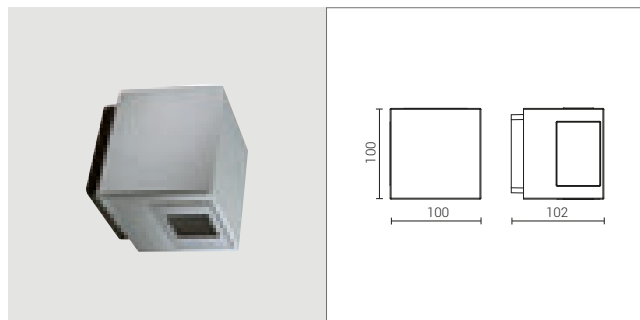

1 faccia aperta | 1 window



30°

70°

CODE	LAMP	W	lm Nominali-Real output		GR	GM	BI
1040*	☉ Led 30°	3	185	20			
1041*	☉ Led 70°	3	185	124			

Colore Corten a richiesta.
IP 65 / Classe II / IK 08
CRI 85 / Driver IN / 700 mA
230V / 50 Hz
CE

Tonalità 3000K o 4000K. Aggiungere 3K o 4K al codice dopo il colore.

Corten colour available upon request.

IP 65 / Class II / IK 08
CRI 85 / Driver IN / 700 mA
230V / 50 Hz
CE

Color temperature available 3000K or 4000K. Add 3K or 4K to the code after the color.

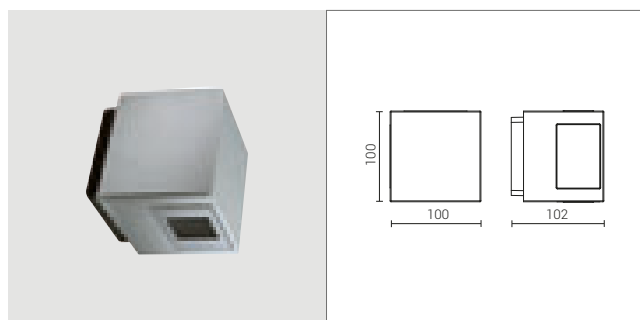

2 facce aperte | 2 windows

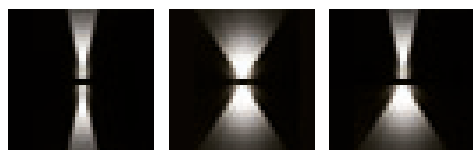

30° - 30°

70° - 70°

30° - 70°

CODE	LAMP	W	lm Nominali-Real output		GR	GM	BI
1042*	☉ Led 30°+30°	2x3	370	36			
1043*	☉ Led 70°+70°	2x3	370	241			
1044*	☉ Led 30°+70°	2x3	370	135			

Code + Colour + Tonality

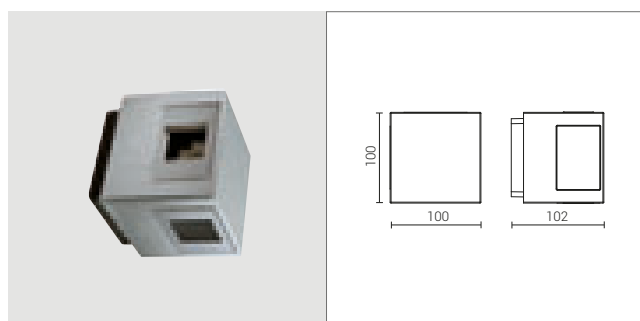

4 facce aperte | 4 windows

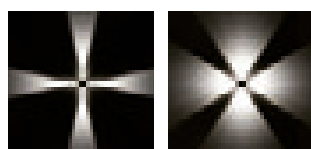

30°

70°

CODE	LAMP	W	lm Nominali-Real output		GR	GM	BI
1045*	☉ Led 30°	4x3	740	54			
1046*	☉ Led 70°	4x3	740	337			

Code + Colour + Tonality

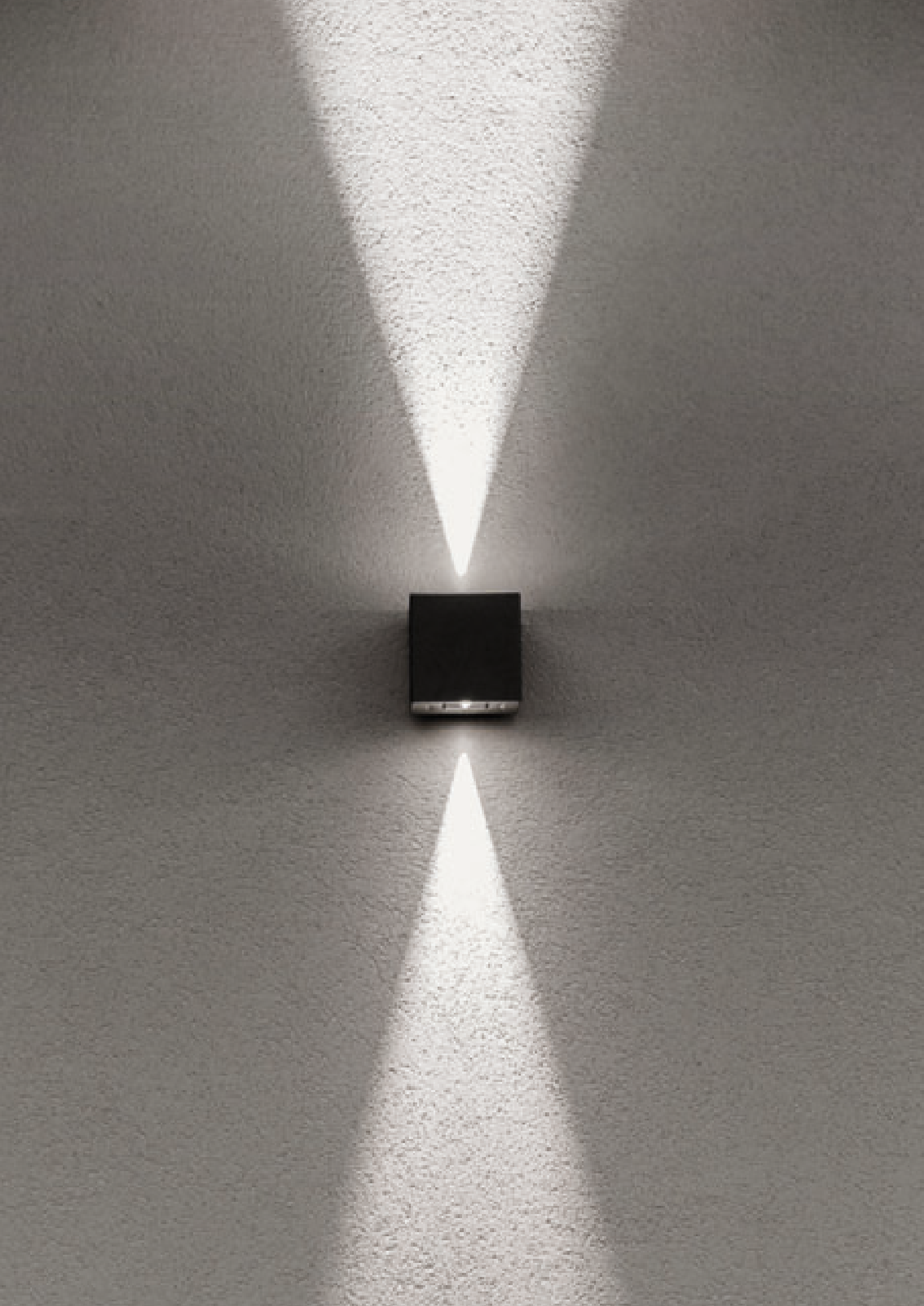

K³ MINILED

Effetti a parete
Wall effect



L80 B20
60.000

EN 60598-1
:2015

EN 60598-2
-1:1989

K³ MINILED INOX AISI 316L | K³ MINILED STAINLESS STEEL AISI 316L

Code + Colour + Tonality

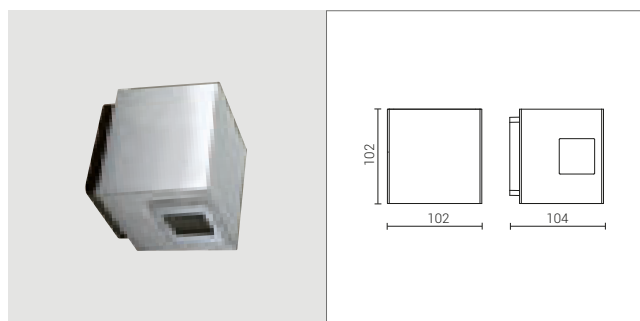

1 faccia aperta | 1 window



30°

70°

CODE	LAMP	W	lm Nominali-Real output		IN
1050*	☉ Led 30°	3	185	20	
1051*	☉ Led 70°	3	185	124	

IP 65 / Classe II / IK 10
CRI 85 / Driver IN / 700 mA
230V / 50 Hz

CE

Tonalità 3000K o 4000K. Aggiungere 3K o 4K al codice dopo il colore.

IP 65 / Classe II / IK 10
CRI 85 / Driver IN / 700 mA
230V / 50 Hz

CE

Color temperature available 3000K or 4000K. Add 3K or 4K to the code after the color.

Code + Colour + Tonality

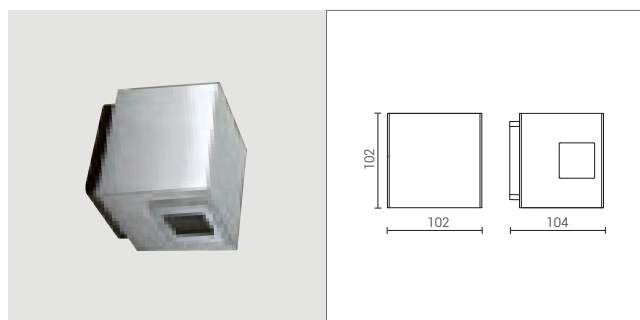

2 facce aperte | 2 windows



30° - 30°

70° - 70°

30° - 70°

CODE	LAMP	W	lm Nominali-Real output		IN
1052*	☉ Led 30°+30°	2x3	370	36	
1053*	☉ Led 70°+70°	2x3	370	241	
1054*	☉ Led 30°+70°	2x3	370	135	

Code + Colour + Tonality

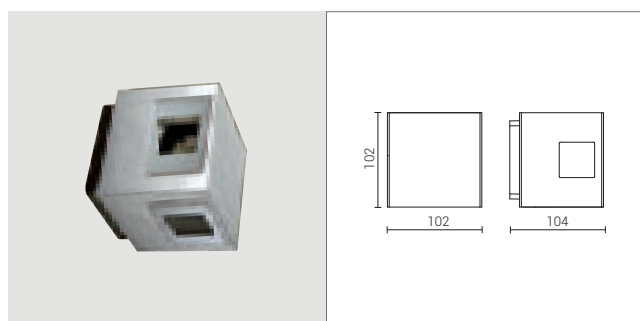

4 facce aperte | 4 windows

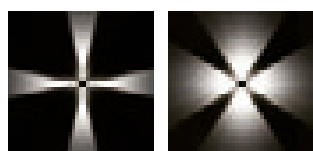

30°

70°

CODE	LAMP	W	lm Nominali-Real output		IN
1055*	☉ Led 30°	4x3	740	54	
1056*	☉ Led 70°	4x3	740	337	

K³ MINILED

PICCHETTO | SPIKE

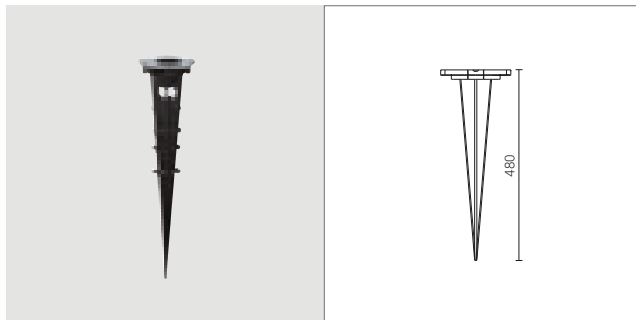

CODE DESCRIZIONE / DESCRIPTION

1090 Picchetto / Spike

Struttura in tecnopolimero.

Technopolymer body.





K³ POWER

Effetti a parete
Wall effect

Alluminio - Aluminium



Una apertura
One window

LED

Inox AISI 316L - AISI 316L Stainless steel



Una apertura
One window

LED

Due aperture
Two windows



LED

Due aperture
Two windows

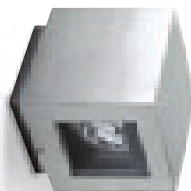

LED

Quattro aperture
Four windows

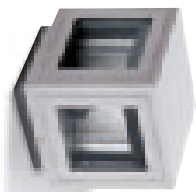

Quattro aperture
Four windows

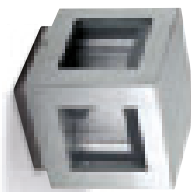

COMBINAZIONI DEI FASCI LUMINOSI | ANGLE BEAM COMBINATIONS

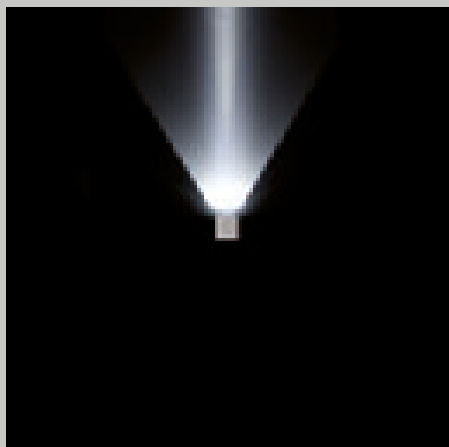

Un fascio 20°
20° one window

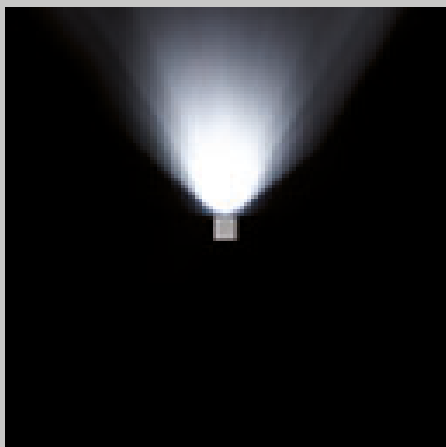

Un fascio 50°
50° one window

La Serie K³ Power è composta da 3 apparecchi

- cubo con una finestra
- cubo con due finestre contrapposte
- cubo con quattro finestre

Il fascio luminoso è disponibile in due diverse angolazioni:

- stretto, di 20°
- diffuso, di 50°

K³ Power range consists of three bodies:

- cube with one window
- cube with two opposite windows
- cube with four opposite windows

Two angle beam available:

- 20°
- 50°

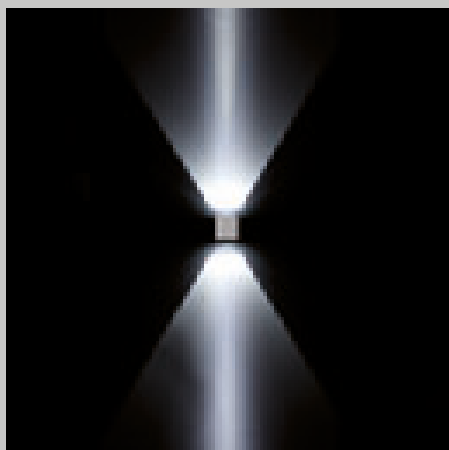

Due fasci 20°
20° two windows

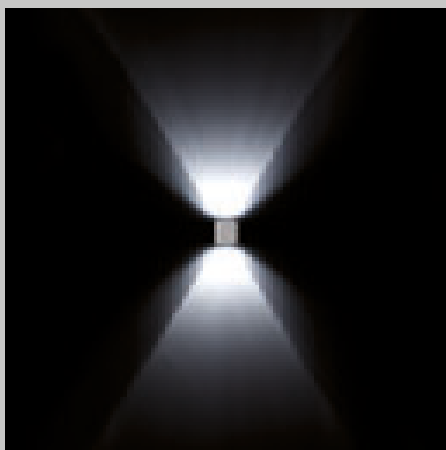

Due fasci 50°
50° two windows

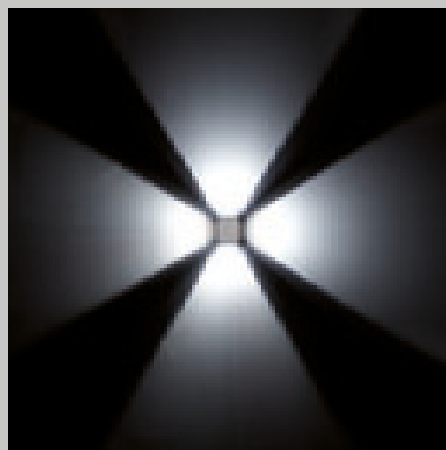

Quattro fasci 50°
50° four windows

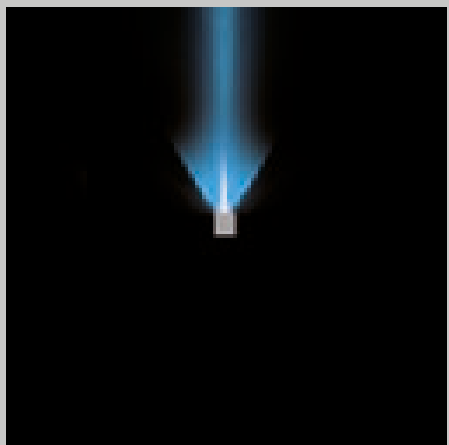

Sono disponibili 4 filtri dicroici colorati (rosso, arancio, blu, verde) per effetti scenografici.
4 dichroic color filters enhance the light effects - red, blue, green and orange.

K³ POWER

Effetti a parete
Wall effect

CARATTERISTICHE GENERALI

- Apparecchio per esterno ad alta potenza di forma cubica.
- **Struttura:** diffusore in vetro temprato ultrawhite. Corpo in alluminio pressofuso a basso tenore di rame o in inox AISI 316L. Viti a brugola in tinta.
- Esclusive ottiche interne in Al 98,8 lucido studiate per esaltare il fascio luminoso.
- Con l'accessorio cod. 1191, l'apparecchio diventa orientabile.
- Installabile a parete ed a terra in giardino con apposito picchetto.
- Ingresso cavi dal retro.
- **Sorgenti luminose** a basso consumo o Led di nuova generazione con vita garantita 60.000 h con successivo scadimento max del 20%. Driver incorporato.
- **Finitura:** per alluminio, decappaggio + fosfocromatazione + fondo epossidico + verniciatura con polveri epossidiche stabilizzate anti UV. Per inox: spazzolato e lucidato.
- Costruito in conformità alle norme europee EN 60598-1:2015 **CE**

GENERAL FEATURES

- High power, cubic shape outdoor fitting.
- **Structure:** ultrawhite transparent tempered glass diffuser. Low copper content die-cast aluminium or AISI 316L stainless steel body. Matching Allen screws.
- Exclusive internal optics in polished Al 98.8 designed to accentuate the angle beam.
- Accessory code 1191 helps the fitting become adjustable.
- Can be installed on wall and in the ground in the garden using a special spike.
- Cable entry from the back.
- Low consumption **light sources** or new generation LEDs with minimum life 60,000 h with subsequent deterioration max 20%. Driver inside.
- **Finish:** for aluminium, pickling + phosphochrome + epoxy basic coating + UV resistant stabilised epoxy powder coating. For stainless steel: brushed and polished.
- Manufactured in compliance with European standards EN 60598-1:2015 **CE**

RIFLETTORI ILLUMINOTECNICI

L'efficienza luminosa superiore al 69% è assicurata da riflettori illuminotecnici in alluminio brillantato 99,8, appositamente progettati per ottimizzare la diffusione della luce.

- 1 - Riflettore singolo
- 2 - Riflettore doppio
- 3 - Riflettore quadruplo

LIGHTING REFLECTORS

Parabolic Al 99,8 reflectors govern and push the light with high efficiency - until 69%.

- 1 - Single reflector
- 2 - Double reflector
- 3 - Quadruple reflector



MATERIALI E COLORI

Gli apparecchi sono disponibili in alluminio grigio (1), alluminio bianco (2), alluminio grafite (3) e in acciaio inox AISI 316L (4).

MATERIALS AND COLOURS

The lighting fittings are available in primary aluminium, finished in light grey (1), matt white (2) and graphite (3), and in AISI 316L stainless steel (4).

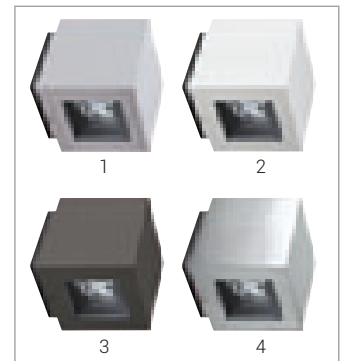

EFFICIENZA LUMINOSA

L'efficienza luminosa della versione 35W ioduri metallici, grazie al rendimento luminoso fino al 72% e allo studio illuminotecnico dei diffusori, è molto elevata.

LIGHTING EFFICIENCY

The lighting efficiency of the 35 W metal Halide version is extremely high, thanks to high efficiency up to 72% and to the lighting study of diffusers.

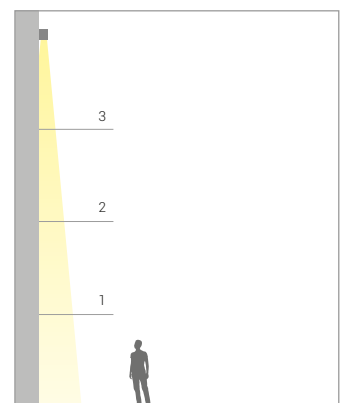

SMONTAGGIO SEMPLIFICATO

Lo smontaggio è semplificato ed è agevole anche con l'apparecchio installato.

EASY DISASSEMBLY

Assembling and maintenance allowed even if the fixture is already installed.



K³ POWER

Effetti a parete
Wall effect



K³ POWER ALLUMINIO | K³ POWER ALUMINIUM

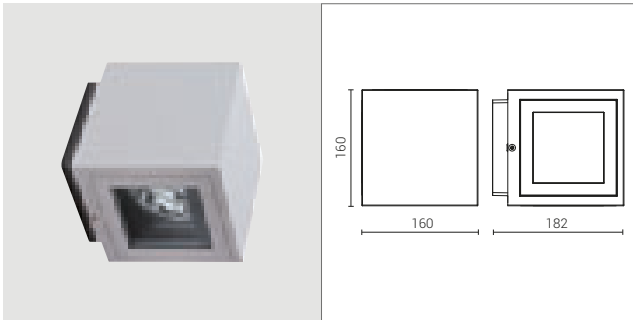

Rendimento 69% per 1 luce / 63% per 2 luci.

Colore Corten a richiesta.
IP 65 / Classe II / IK 08
CRI 85 / Driver IN / 350 mA
230V / 50 Hz

CE
Tonalità 3000K o 4000K. Aggiungere 3K o 4K al codice dopo il colore.

Efficiency: 69% for 1 light / 63% for 2 lights.

Corten colour available upon request.
IP 65 / Class II / IK 08
CRI 85 / Driver IN / 350 mA
230V / 50 Hz

CE
Color temperature available 3000K or 4000K. Add 3K or 4K to the code after the color.

1 faccia aperta | 1 window

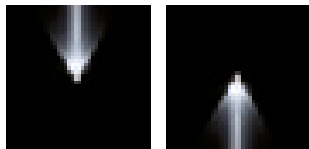

20°

20°

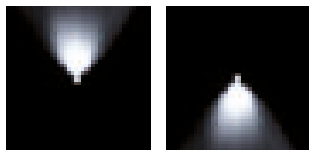

50°

50°

Code + Colour + Tonality

CODE	LAMP	W	lm	Nominali-Real output	GR	GM	BI
1100*	GU 6,5	20					
1101*	GU 6,5	35					
1102*	Led	9,5	1200	792			

Code + Colour + Tonality

CODE	LAMP	W	lm	Nominali-Real output	GR	GM	BI
1103*	GU 6,5	20					
1104*	GU 6,5	35					
1105*	Led	9,5	1200	679			
1106*	E 27 L max 128mm	75					

Lampadine escluse per 20W e 35W Ioduri Metallici. Led incluso per cod. 1102 e 1105.

Without lamps for 20W and 35W metal halide. Led included for 1102 and 1105.

2 facce aperte | 2 windows

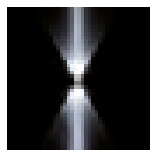

20°

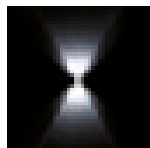

50°

Code + Colour + Tonality

CODE	LAMP	W	lm	Nominali - Real output	GR	GM	BI
1107*	GU 6,5	20					
1108*	GU 6,5	35					
1109*	Led	2x9,5	1200x2	1584			

Code + Colour + Tonality

CODE	LAMP	W	lm	Nominali-Real output	GR	GM	BI
1120*	GU 6,5	20					
1121*	GU 6,5	35					
1122*	Led	2x9,5	1200x2	1358			
1123*	E 27 L max 128mm	75					

Lampadine escluse per 20W e 35W Ioduri Metallici. Led incluso per cod. 1109 e 1122.

Without lamps for 20W and 35W metal halide. Led included for 1109 and 1122.

4 facce aperte | 4 windows



50°

Code + Colour + Tonality

CODE	LAMP	W	lm	Nominali-Real output	GR	GM	BI
1125*	GU 6,5	20					
1126*	GU 6,5	35					
1128*	E 27 L max 128mm	75					

Lampadine escluse.

Without lamps.



K³ POWER INOX AISI 316L | K³ POWER STAINLESS STEEL AISI 316L

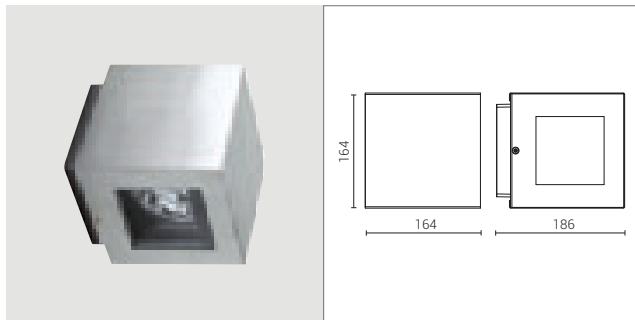

Rendimento 69% per 1 luce / 63% per 2 luci.

IP 65 / Classe II / IK 08
CRI 85 / Driver IN / 350 mA
230V / 50 Hz
CE

Tonalità 3000K o 4000K. Aggiungere 3K o 4K al codice dopo il colore.

Efficiency: 69% for 1 light / 63% for 2 lights.

IP 65 / Class II / IK 08
CRI 85 / Driver IN / 350 mA
230V / 50 Hz
CE

Color temperature available 3000K or 4000K. Add 3K or 4K to the code after the color.

1 faccia aperta | 1 window

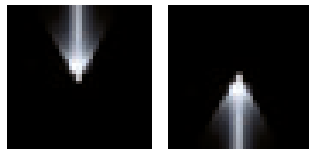

20° 20°

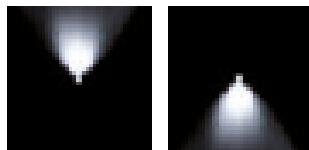

50° 50°

Code + Colour + Tonality

CODE	LAMP	W	lm Nominali-Real output	IN
1110*	GU 6,5	20		
1111*	GU 6,5	35		
1112*	Led	9,5	1200 792	

Code + Colour + Tonality

CODE	LAMP	W	lm Nominali-Real output	IN
1113*	GU 6,5	20		
1114*	GU 6,5	35		
1115*	Led	9,5	1200 679	
1116*	E 27 L max 128mm	75		

Lampadine escluse per 20W e 35W Ioduri Metallici. Led incluso per cod. 1112 e 1115.

Without lamps for 20W and 35W metal halide. Led included for 1112 and 1115.

Code + Colour + Tonality

CODE	LAMP	W	lm Nominali - Real output	IN
1117*	GU 6,5	20		
1118*	GU 6,5	35		
1119*	Led	2x9,5	1200x2 1584	

Code + Colour + Tonality

CODE	LAMP	W	lm Nominali-Real output	IN
1130*	GU 6,5	20		
1131*	GU 6,5	35		
1132*	Led	2x9,5	1200x2 1358	
1133*	E 27 L max 128mm	75		

Lampadine escluse per 20W e 35W Ioduri Metallici. Led incluso per cod. 1119 e 1132.

Without lamps for 20W and 35W metal halide. Led included for 1119 and 1132.

Code + Colour + Tonality

CODE	LAMP	W	lm Nominali-Real output	IN
1135*	GU 6,5	20		
1136*	GU 6,5	35		
1138*	E 27 L max 128mm	75		

Lampadine escluse.

Without lamps.

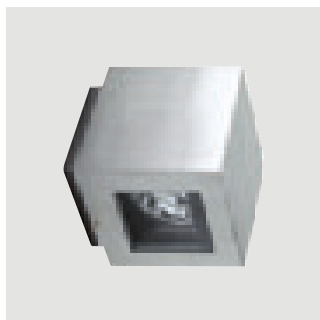

2 facce aperte | 2 windows

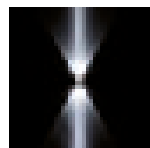

20°

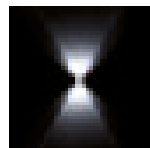

50°

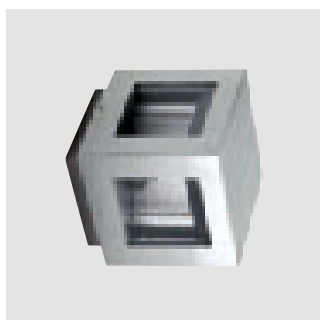

4 facce aperte | 4 windows

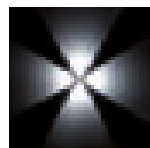

50°



K³ POWER

Effetti a parete
Wall effect

FILTRI COLORE | COLOR FILTERS

Code + Colour

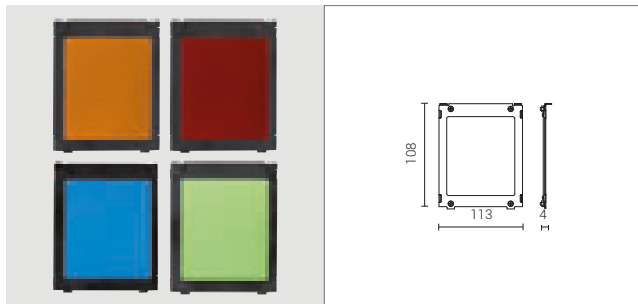

CODE DESCRIZIONE / DESCRIPTION

RO AR BL VE

1096* Filtro dicroico / Dichroic filter

Filtro colore con trattamento dicroico.
Vetro in borosilicato.
Telaio in acciaio nero.
1 filtro per 1 faccia.

*Dichroic finish.
Color and glass amalgam system.
Black steel frame.
1 filter for 1 window.*

STAFFA A SNODO | ARTICULATED BRACKET

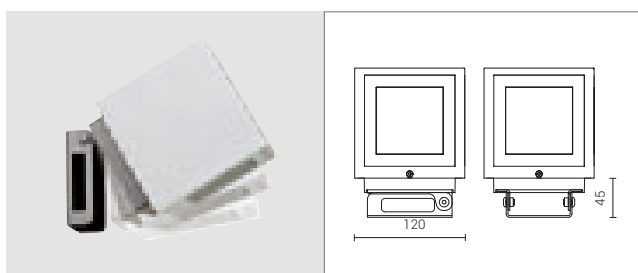

CODE DESCRIZIONE / DESCRIPTION

1191 Staffa a snodo / Articulated bracket

Rotazione massima 90°.

90° rotation allowed.

PICCHETTO | SPIKE



CODE DESCRIZIONE / DESCRIPTION

1192 Picchetto / Spike

Picchetto da interrare, comprensivo di staffa a snodo cod. 1191.

Spike to be interred, including articulated bracket code 1191.

PIASTRA CON TIRAFONDI | PLATE WITH ANCHORING SET



CODE DESCRIZIONE / DESCRIPTION

1193 Piastra con tirafondi / Plate with anchoring set

Piastra inox da interrare, comprensiva di staffa a snodo cod. 1191.

Stainless steel plate to be interred, including articulated bracket code 1191.

GRIGLIA ANTIABBAGLIANTE | ANTI-DAZZLING FLANGED LOUVERS

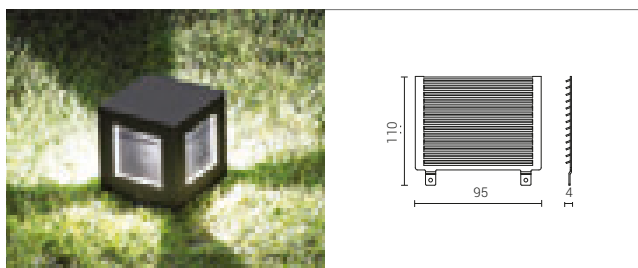

CODE DESCRIZIONE / DESCRIPTION

1194 Griglia in ferro antiabbagliante / Anti-dazzling flanged louvers

Da installare internamente.

To be installed inside.



CORINTHIA

EFFETTI A PARETE
WALL EFFECT

L'illuminazione architettonica ora può contare su una nuova opportunità: la Serie CORINTHIA di Goccia Illuminazione. I cilindri, finemente scanalati come le eleganti colonne nell'antica Grecia, accolgono sorgenti luminose di assoluta avanguardia. Il design elegante e curato ne facilita l'inserimento in ogni ambiente, classico o contemporaneo. Grazie alle particolari soluzioni tecniche, tutte le lampade sono basculanti e regolabili in modo da orientare la luce verso la parete, accentuando l'effetto wall-washer. Particolare cura è stata posta nella realizzazione del cristallo temperato di chiusura che è fresato a filo struttura per impedire ristagni d'acqua. Potenze e dimensioni rendono le lampade della Serie CORINTHIA ideali per l'illuminazione architettonica di facciate per edifici pubblici, privati o industriali.

Architectural illumination can now utilize something new: the CORINTHIA series created by Goccia Illuminazione. Elegantly striated to perfection, metal cylinders as enchanting as ancient Greek Corinthian columns, are ready for integration in modern or classic constructions. The light beams of 18, 38 and 90 degrees can by means of an internal metal bascule direct the light to the wall behind the CORINTHIA thus increasing the wall-washer effect. Goccia Illuminazione has once again created an artistic lighting tool not only versatile but also apt to satisfy the most difficult architectural lighting requirements







CORINTHIA

Effetti a parete
Wall effect

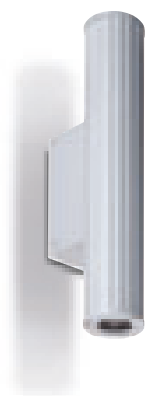

Una apertura
One window
LED

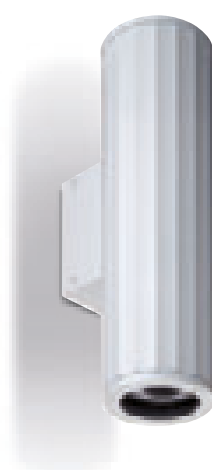

Una apertura
One window
LED

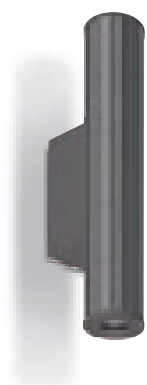

Due aperture
Two windows
LED

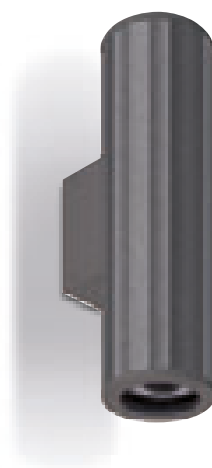

Due aperture
Two windows
LED



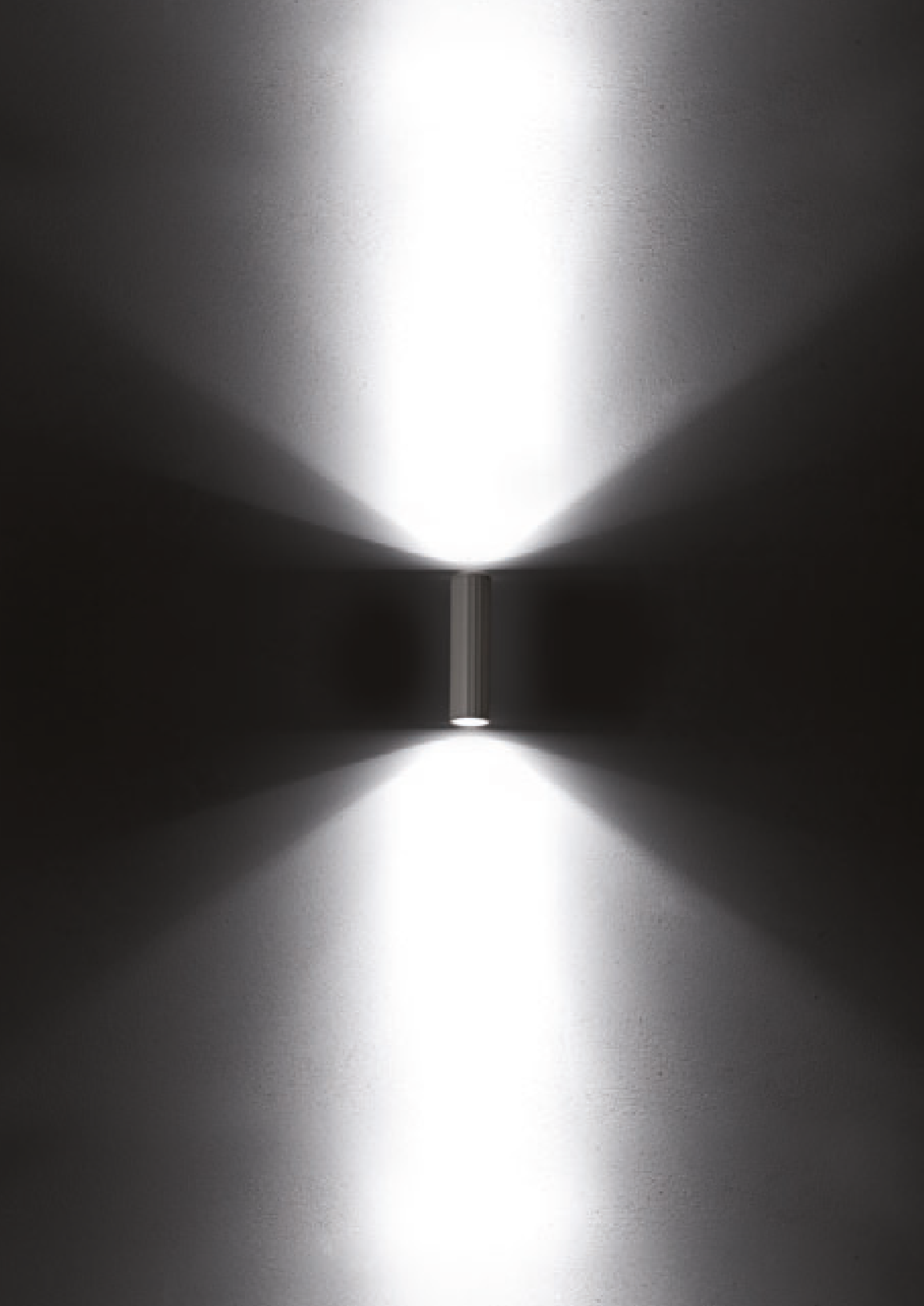

CORINTHIA

Effetti a parete
Wall effect

CARATTERISTICHE GENERALI

- Apparecchio cilindrico per esterno ad effetto wall-washer.
- **Struttura:** diffusore in vetro temprato trasparente. Corpo in alluminio estruso scanalato. Cornici fermavetro e scatola di fissaggio a muro in alluminio pressofuso a basso tenore di rame.
- Vetro e cornice a pari livello per evitare ristagni d'acqua.
- Ottiche orientabili $\pm 5/10\%$ per accentare l'effetto wall-washer.
- Ingresso cavi dal retro mediante morsetteria IP68.
- Collegamento elettrico fra sorgenti luminose e scatola di fissaggio precablato di serie.
- **Sorgenti luminose** a basso consumo o Led di nuova generazione con vita garantita 60.000 h con successivo scadimento max del 20%. Driver incorporato.
- **Finitura:** per alluminio, decappaggio + fosfocromatazione + fondo epossidico + verniciatura con polveri epossidiche stabilizzate anti UV.
- Costruito in conformità alle norme europee EN 60598-1:2015 **CE**

CORINTHIA Ø 60 mm

Lampada doppia o singola
basculanti $\pm 5^\circ$
Apertura fascio $18^\circ - 38^\circ - 90^\circ$

CORINTHIA Ø 120 mm

Lampada doppia o singola
basculanti $\pm 10^\circ$
Apertura fascio $18^\circ - 38^\circ - 90^\circ$

CORINTHIA Ø 60 mm

1 or 2 lamps available
adjustable $\pm 5^\circ$
Angle beam $18^\circ - 38^\circ - 90^\circ$

CORINTHIA Ø 120 mm

1 or 2 lamps available
adjustable $\pm 10^\circ$
Angle beam $18^\circ - 38^\circ - 90^\circ$

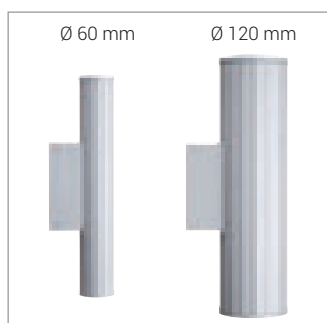

Ø mm	Tipo Type	Watt	lm nominali Nominal lm
Ø60	Led	3	185
	Led	9,5	1200
Ø120	Ioduri Metallici Metal Halide	20	1700
		35	3100

STRUTTURA IN ALLUMINIO

- 1 - Vetro a filo
- 2 - Riflettore
- 3 - Lampada basculante
- 4 - Dissipatore
- 5 - Driver
- 6 - Scatola di fissaggio con cablaggi
- 7 - Corpo in alluminio

ALUMINIUM STRUCTURE

- 1 - Milled tempered glass
- 2 - Reflector
- 3 - Adjustable light source
- 4 - Heat sink
- 5 - Driver
- 6 - Box to fix at wall
- 7 - Aluminium housing

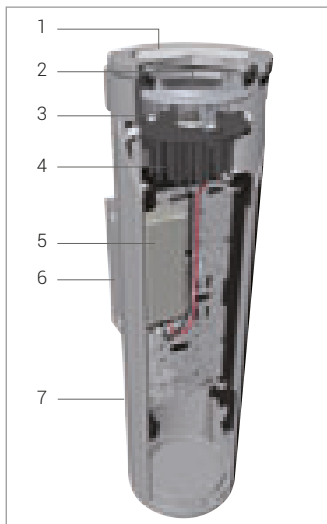

GENERAL FEATURES

- Outdoor cylindrical wall-washer effect fitting.
- **Structure:** transparent tempered glass diffuser. Striated extruded aluminium body. Glazing bead frame and box to fix to wall in die-cast aluminium with low copper content.
- Glass and frame at the same level to prevent water puddles.
- $\pm 5/10\%$ adjustable optics to accentuate the wall-washer effect.
- Cable entry from the back via IP68 terminal block.
- Electrical connection between light sources and pre-wired standard box to fix to wall.
- Low consumption **light sources** or new generation LEDs with minimum life 60,000 h with subsequent deterioration max 20%. Driver inside.
- **Finish:** for aluminium, pickling + phosphochrome + epoxy basic coating + UV resistant stabilised epoxy powder coating.
- Manufactured in compliance with European standards EN 60598-1:2015 **CE**

CRISTALLO ANTI RISTAGNO

Per impedire ristagni d'acqua sulla faccia superiore, il cristallo temprato di chiusura è fresato a filo struttura.

ANTI-STAGNATION CRYSTAL

The glass in line with the frame avoids water puddles.



RIFLETTORI PER IODURI

Nella versione a ioduri metallici, gli speciali riflettori provvedono alla distribuzione della luce secondo l'apertura del fascio a 18° , 38° o 90° .

REFLECTORS FOR HALIDES

For the metal halide version, an adjustable and optical parabolic reflector will guarantee a uniform light diffusion.



BASCULAGGIO

Tutte le lampade sono basculanti e regolabili con un'angolazione fino a $\pm 5^\circ$ o $\pm 10^\circ$, in modo da orientare la luce verso la parete per accentuare l'effetto wall-washer.

TILTING

For any version the light firing is adjustable with $\pm 5^\circ$ or $\pm 10^\circ$, in order to accent the light effect on the wall, when required.

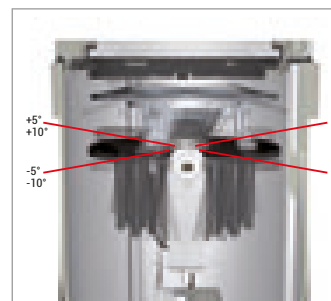

CABLAGGIO

Morsetteria IP68.

WIRING

IP68 terminal block.



CORINTHIA

Effetti a parete
Wall effect



CORINTHIA ø 60 mm

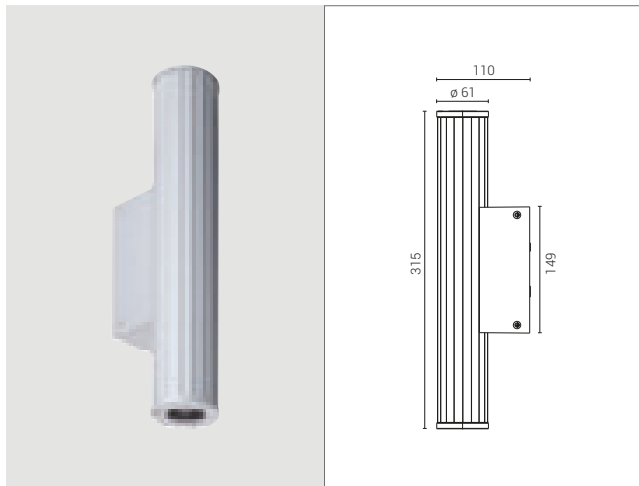

Sorgente luminosa basculante $\pm 5^\circ$.
Colore Corten a richiesta.
IP 65 / Classe II / IK 10
CRI 85 / Driver IN / 700 mA
230V / 50 Hz
C€
Tonalità 3000K o 4000K.
Aggiungere 3K o 4K al codice dopo il colore.

Adjustable light source $\pm 5^\circ$.
Corten colour available upon request.
IP 65 / Class II / IK 10
CRI 85 / Driver IN / 700 mA
230V / 50 Hz
C€
Color temperature available 3000K or 4000K.
Add 3K or 4K to the code after the color.

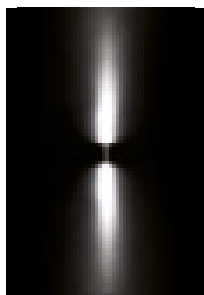

18° Led

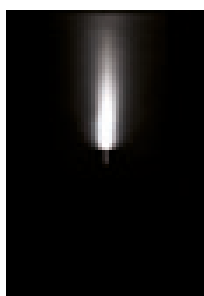

18° Led

Code + Colour + Tonality

CODE	LAMP	W	lm Nominali-Real output	GR	GM
1201*	⊙ Led	2x3	2x185 202		



standard



option
aggiungere 38 al codice
add 38 to the code



option
aggiungere 90 al codice
add 90 to the code

Code + Colour + Tonality

CODE	LAMP	W	lm Nominali-Real output	GR	GM
1202*	⊙ Led	1x3	1x185 101		



standard



option
aggiungere 38 al codice
add 38 to the code



option
aggiungere 90 al codice
add 90 to the code

CORINTHIA



CORINTHIA ø 120 mm

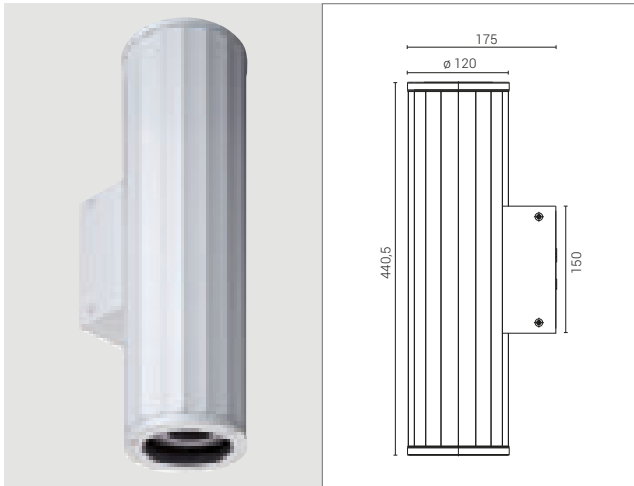

Sorgente luminosa basculante $\pm 10^\circ$.
 Colore Corten a richiesta.
 IP 65 / Classe II / IK 10
 CRI 85 / Driver IN / 350 mA
 230V / 50 Hz
 C €

Tonalità 3000K o 4000K.
 Aggiungere 3K o 4K al codice dopo il colore.

*Adjustable light source $\pm 10^\circ$.
 Corten colour available upon request.
 IP 65 / Class II / IK 10
 CRI 85 / Driver IN / 350 mA
 230V / 50 Hz
 C €*
Color temperature available 3000K or 4000K.
Add 3K or 4K to the code after the color.

Code + Colour + Tonality

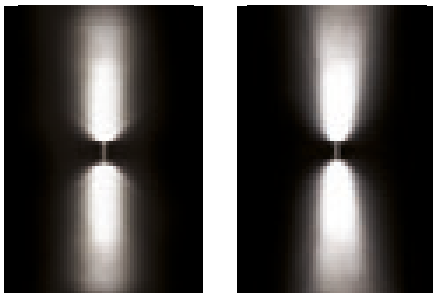

18° Led

18° Ioduri metallici
18° Metal halide

CODE	LAMP	W	lm Nominali - Real output	GR	GM
1206*	GU 6,5	2x20			
1207*	GU 6,5	2x35			
1208*	Led	2x9,5	2x1200 1612		
1209*	GU 10 L max 90mm	2x10			



standard



option

aggiungere 38 al codice
add 38 to the code



option

aggiungere 90 al codice
add 90 to the code

Code + Colour + Tonality

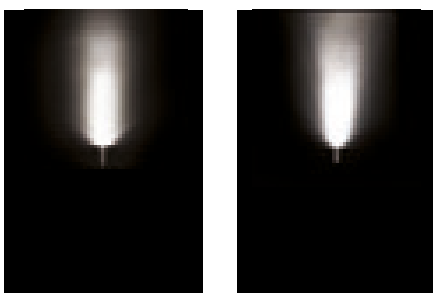

18° Led

18° Ioduri metallici
18° Metal halide

CODE	LAMP	W	lm Nominali - Real output	GR	GM
1211*	GU 6,5	1x20			
1212*	GU 6,5	1x35			
1213*	Led	1x9,5	1200 806		
1214*	GU 10 L max 90mm	10			



standard



option

aggiungere 38 al codice
add 38 to the code



option

aggiungere 90 al codice
add 90 to the code



VOLTO

EFFETTI A PARETE WALL EFFECT



Volto



Volto con bracci
Volto with arms



Volto Led

LED



Volto basculante
Volto balancing supports



Volto frangiluce
Volto louvers

Ci sono spazi urbani e strutture architettoniche capaci di acquisire nuova suggestione grazie ad un'illuminazione attenta. Per questo nasce VOLTO, un apparecchio hi-tech da esterni con struttura in alluminio e vetro temperato serigrafato, particolarmente adatto ad essere posizionato sopra un capitello per illuminare volti, archi, loggiati e porticati. Dalle dimensioni ridotte e con un'accattivante forma geometrica, VOLTO si inserisce perfettamente negli angoli a parete, a soffitto o su piano. La luce è direzionabile verso l'alto o verso il basso, e il frangiluce dà un effetto anti-abbagliante, che crea una luminosità mirata e scenografica sulle volte.

Some architectural Archs and Vaults become a new scenario with glamorous effect when the right light accent the colors. That's why VOLTO, an hi-tech lighting fittings capable to be inserted over a capital to light on the Vault. The peculiar triangular shape and the small dimensions make VOLTO the right match for corner, a wall, wherever a not invasive fixture is required. VOLTO can be oriented towards up or down, can stay directly at wall or can be oriented with the special adjustable arms. The antidazzling louvers protect from the light pollution if installed upwards so as downwards.



VOLTO

Effetti a parete
Wall effect

CARATTERISTICHE GENERALI

- Apparecchio per esterno di forma triangolare.
- **Struttura:** diffusore in vetro temprato trasparente e serigrafato. Corpo e cornice fermavetro in alluminio pressofuso a basso tenore di rame. Posizionabile con orientamento verso l'alto o verso il basso.
- Il braccio cod. 5080, l'apparecchio diventa completamente orientabile.
- Con il supporto basculante cod. 5066, è possibile regolare l'effetto wall-washer.
- L'apparecchio può essere installato a terra grazie all'accessorio cod. 5080.
- Ingresso cavi dal retro o laterale.
- **Sorgenti luminose** ad alto rendimento e basso consumo o Led di nuova generazione con ottiche dedicate, vita garantita 60.000 h con successivo scadimento max del 20%. Driver incorporato.
- **Finitura:** su alluminio, decappaggio + fosfocromatazione + fondo epossidico + verniciatura con polveri epossidiche stabilizzate anti UV.
- Costruito in conformità alle norme europee EN 60598-1:2015 **CE**

GENERAL FEATURES

- *Triangular shape outdoor fitting.*
- **Structure:** transparent and serigraph tempered glass diffuser. Low copper content die-cast aluminium body and glazing bead frame. Adjustable upward or downward.
- *Arm code 5080 helps the fitting become fully adjustable.*
- *With tilting support code 5066 to adjust the wall-washer effect.*
- *The fitting can be installed on the ground thanks to accessory code 5080.*
- *Cable entry from the rear or side.*
- *High performance, low consumption light sources or new generation LEDs with special optics with minimum life 60,000 h with subsequent deterioration max 20%. Driver inside.*
- **Finish:** on aluminium, pickling + phosphochrome + epoxy basic coating + UV resistant stabilised epoxy powder coating.
- *Manufactured in compliance with European standards EN 60598-1:2015 **CE***

VERSIONE LED

4 gruppi Led da 6,5W e 660 lumen ciascuno.

LED VERSION

4 led units 6,5 W and 660 lumen each.



FRANGILUCE

Il frangiluce dà un effetto anti-abbagliante, che crea una luminosità mirata e scenografica sulle volte.

LOUVERS

The louvres give an anti-dazzle effect, creating targeted, theatrical brightness on faces.



LUCE ORIENTABILE

L'apparecchio Volto può essere installato per orientare la luce verso l'alto o verso il basso. I bracci snodati consentono la rotazione dell'apparecchio fino a 60°.

ADJUSTABLE LIGHT

Volto fittings can be installed to direct light upward or downward. The adjustable arms allow for fitting rotation up to 60°.

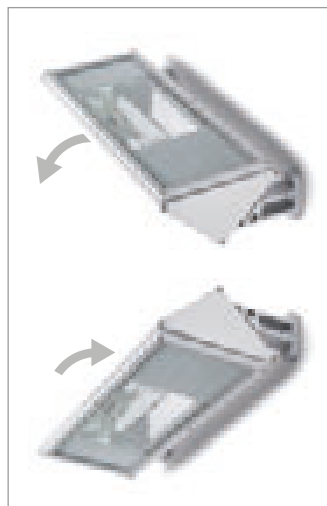

VERSIONE IODURI METALLICI

Vetro temprato serigrafato con riflettore in 99,8 brillantato.

METAL HALIDE VERSION

Serigraphic tempered glass with 99,8 polished aluminium reflector.

VOLTO

Effetti a parete
Wall effect



VOLTO

Code + Colour

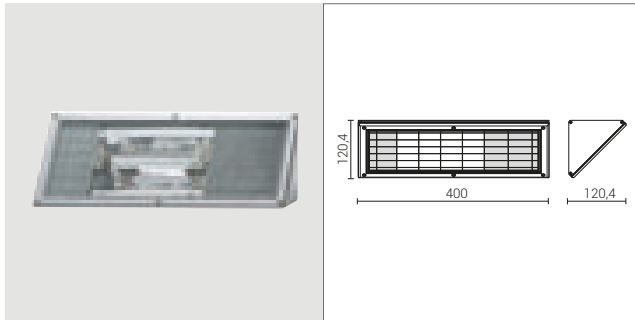

CODE	LAMP	W	NE	SI
5861*	Rx7s	70		

Vetro temprato serigrafato.
Riflettore in 99,8 brillantato.
Reattore elettronico incorporato.
Apertura del fascio 90° diffuso.
Colore bianco a richiesta.
IP 65 / Classe II / IK 08
CE

*Serigraphic tempered glass.
99,8 polished aluminium reflector.
Electronic ballast inside.
90° angle beam.
White colour on request.
IP 65 / Class II / IK 08
CE*

VOLTO LED

Code + Colour + Tonality

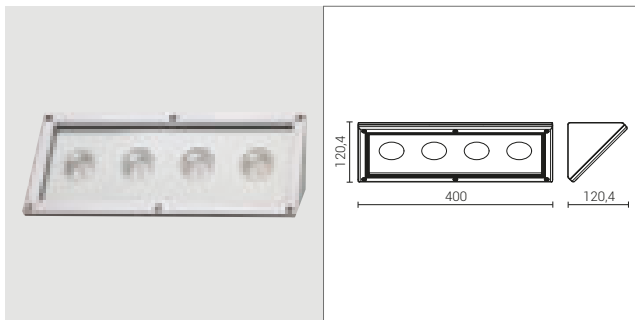

CODE	LAMP	W	Im Nominali-Real output	NE	SI
5863*	Led	4x6,5	2640 2275		

Vetro temprato.
Collegamento in parallelo per 2 driver.
IP 65 / Classe II / IK 10
CRI 85 / Driver IN / 350 mA
230V / 50 Hz
CE
Tonalità 3000K o 4000K.
Aggiungere 3K o 4K al codice dopo il colore.

*Clear tempered glass.
Independent two parallel wirings.
IP 65 / Class II / IK 10
CRI 85 / Driver IN / 350 mA
230V / 50 Hz
CE
Color temperature available 3000K or 4000K.
Add 3K or 4K to the code after the color.*

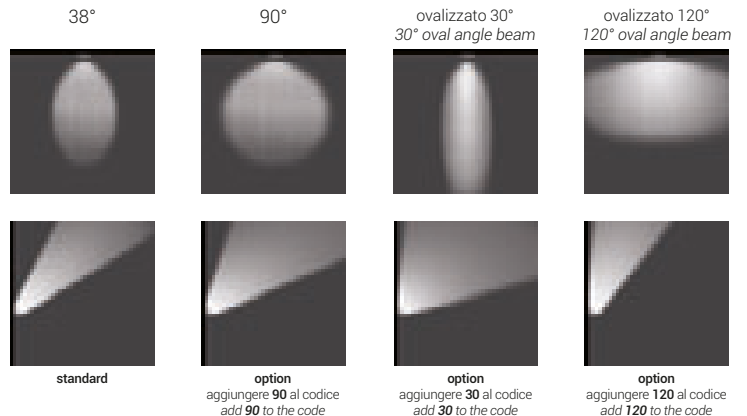

I due fasci ovalizzati si ottengono girando di 90° la stessa lente Fresnel.
The two oval angle beams come by the same Fresnel lens rotated of 90°.

VOLTO

FRANGILUCE | LOUVERS

Code + Colour

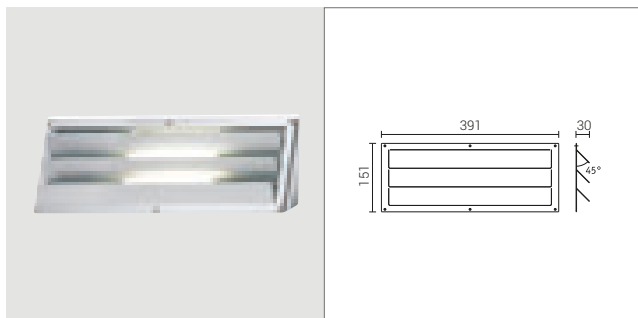

CODE DESCRIZIONE / DESCRIPTION

NE

SI

5864* Frangiluce / Louvers

Acciaio zincato e verniciato.
Alette orientabili.
A montare su 5861.
Solo frangiluce: apparecchio Volto fornito a parte.

CE

Galvanized steel and UV resistant coating surface.
Orientable louvers.
Can be installed on 5861.
Louvers only: Volto fitting supplied separately.

CE

BRACCI SNODATI | ADJUSTABLE ARMS

Code + Colour

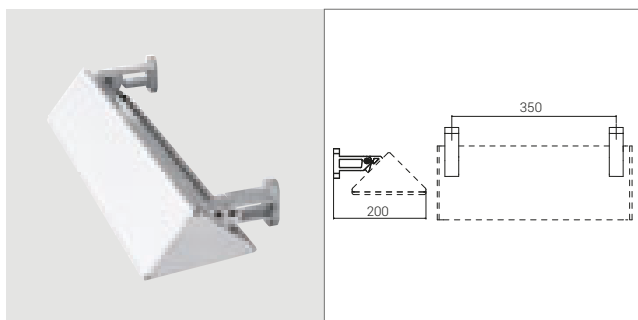

CODE DESCRIZIONE / DESCRIPTION

NE

SI

5080* Coppia di bracci / Arms pair

Orientabile verso l'alto o verso il basso.
Coppia di bracci snodati in alluminio.
Non necessitano di fori aggiuntivi nell'apparecchio.
Completo di accessori di montaggio.
Rotazione consentita 60°.
Solo bracci: apparecchio Volto fornito a parte.

CE

It can be oriented towards up or down.
Aluminium adjustable wall arms.
New holes in the housing not required.
Mounting accessories inside.
60° rotation allowed.
Arms only: Volto fitting supplied separately.

CE

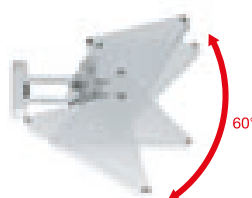

SUPPORTI BASCULANTI | BALANCING SUPPORT

Code + Colour

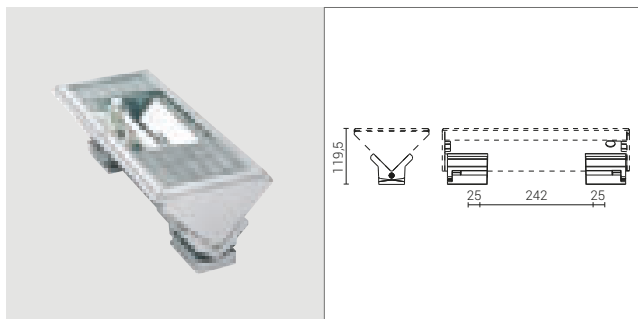

CODE DESCRIZIONE / DESCRIPTION

NE

SI

5066* Coppia supporti / Supports pair

Supporti in alluminio pressofuso.
Orientabilità +/- 15°.
Non necessitano di fori aggiuntivi sull'apparecchio.
Completi di accessori di montaggio.
Solo supporti: apparecchio Volto fornito a parte.

CE

Die-cast aluminium supports.
+/- 15° orientable.
New holes in the housing not required.
Mounting accessories inside.
Support only: Volto fitting supplied separately.

CE

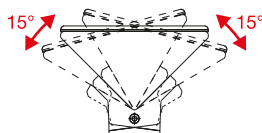



CLOCK

SPOT MINIMALISTA PER ESTERNI
MINIMAL OUTDOOR SPOTLIGHT



CLOCK 80

LED
NEW



CLOCK 120

LED
NEW



Braccio a muro
Wall arm



Picchetto
Garden spike

Lo spot minimalista CLOCK, con il suo design essenziale di forma circolare, è nato per inserirsi perfettamente sia sulle pareti esterne che sul terreno in giardino. Lo spessore contenuto conferisce a CLOCK una personalità decisamente non invasiva, offrendo nel contempo un'emissione luminosa importante. È disponibile in due dimensioni: \varnothing 80 e \varnothing 120 mm, con sorgenti led di nuova generazione nelle varianti sia a tensione di rete (230 V) che a bassa tensione (24 V) con alimentatore remoto. Le particolari ottiche, frutto di accurato progetto illuminotecnico, offrono la possibilità (unica nel suo genere) di scegliere varie aperture del fascio luminoso. La capacità di rotazione del faretto rende estremamente agevole il puntamento e il bloccaggio. Con l'apposito accessorio "Picchetto" è possibile installare il faretto nei giardini a 10 cm dal terreno, come prescritto dalla normativa.

CLOCK is the spotlight with an essential, round design that fits perfectly on outdoor walls and on the ground in your garden. CLOCK's reduced thickness gives it a non-invasive character while ensuring considerable light emission. Available in two sizes: \varnothing 80 and \varnothing 120 mm with state-of-the-art LED sources. Available in both the mains voltage (230 V) and low voltage (24 V) versions with remote power supply. Its optics are the result of an accurate lighting project and allow you to choose various angle beam openings. The arm and spotlight rotate on the two spatial planes, making light direction and fastening extremely easy. The spike allows you to install the spotlight in gardens, 10 cm from the ground, in compliance with law.



CLOCK

Spot per esterni
Outdoor spotlight

CARATTERISTICHE GENERALI

- Spot a tenuta stagna per parete e giardino.
- **Struttura:** corpo e braccio in lega primaria di alluminio a basso tenore di rame.
- Disponibile in due misure: \varnothing 80 e \varnothing 120 mm, completo di braccio di sostegno.
- Corpo lampada orientabile con bloccaggio stabile nel puntamento prescelto.
- Vetro ultrawhite temprato trasparente, saldato alla cornice di chiusura. Disponibile opale su richiesta.
- Installabile a parete, su braccio a muro o in giardino su picchetto.
- **Cablaggio:** lo spot è fornito ermeticamente chiuso e completo di 1 m di cavo interrabile H05RN-F.
- Il cavo può essere collegato alla rete o interrato e può passare nell'apposito foro della basetta del braccio.
- **Sorgenti luminose:** led da 4 e 10 W con CRI 85. Vita garantita 60.000 h con decremento max del 20%.
- Per ciascuno dei due diametri sono disponibili 3 aperture del fascio luminoso: 12°, 40° e 90°.
- Le lampade sono fornite normalmente a tensione di rete (230-240V).
- A richiesta è disponibile una versione a 24V DC o a corrente con driver remoto.
- **Finitura:** verniciatura in doppia mano con vernice poliesteri dopo fosfocromatazione.
- Costruito in conformità alle norme europee EN 60598-1:2015 **CE**

GENERAL FEATURES

- *Watertight wall and garden spotlight.*
- **Structure:** body and arm made of primary aluminium alloy with low copper content.
- Available in two sizes: \varnothing 80 and \varnothing 120 mm, equipped with a support arm.
- Fully adjustable with stable fastening in the chosen point.
- Ultrawhite transparent tempered glass sealed to the frame.
- Opal glass available upon request.
- Can be installed on the wall, on a wall-arm or a spike in the garden.
- **Wiring:** the spotlight is provided hermetically sealed and equipped with a 1 m H05RN-F cable.
- The cable can be connected to the mains or buried and can pass through a special hole in the base of the arm.
- **Light sources:** 4 and 10 W LEDs with CRI 85. Minimum lifetime: 60,000 h with max 20% degradation.
- Three angle beam openings available for each of the two diameters: 12°, 40° and 90°.
- The lamps are provided in the mains voltage version (230-240V).
- 24V DC or constant current remote driver versions available upon request.
- **Finish:** painted with a double coat of polyester paint after phosphochrome.
- Manufactured in compliance with European standards EN 60598-1:2015 **CE**

SPESORE RIDOTTO

Lo spessore di soli 36 mm per i due diametri consente un inserimento non invasivo negli ambienti esterni.

REDUCED THICKNESS

Its 36 mm thickness for both diameters allows it to fit discreetly in outdoor settings.

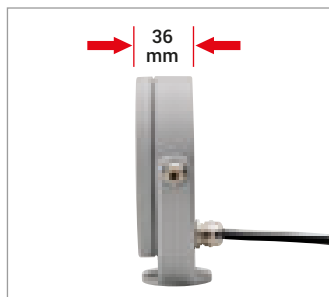

VETRO SIGILLATO

Il vetro frontale ultrawhite è saldato (1) alla cornice di chiusura per consentire la massima tenuta.

SEALED GLASS

The front ultrawhite glass is sealed (1) to the frame for a perfect seal.

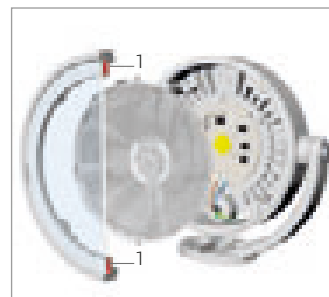

ORIENTABILITÀ VERTICALE

Il corpo ruota intorno al perno di fissaggio per facilitare l'orientamento sul piano verticale. Il blocco è garantito da una vite 8MA.

VERTICAL DIRECTION

The body rotates around the locking pin on the vertical surface to easily adjust its direction. An 8MA screw locks it in place.



CABLAGGIO STAGNO

CLOCK è ermeticamente chiuso con resina bicomponente e fornito con cavo interrabile H05 RN-F.

- 1 - Pressacavo in ottone
- 2 - Resinatura Aquastop
- 3 - Cavo antistrappo

WATERTIGHT WIRING

CLOCK is hermetically sealed with a two-component resin and provided with an H05 RN-F cable.

- 1 - Brass cable gland
- 2 - Aquastop Resin Finish
- 3 - Anti-tear cable

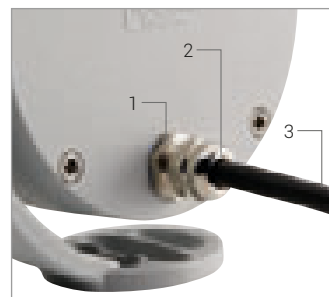

ORIENTABILITÀ ORIZZONTALE

Due asole sulla base consentono l'orientamento orizzontale $\pm 40^\circ$.

HORIZONTAL DIRECTION

Two eyelets on the base allow for a $\pm 40^\circ$ horizontal adjustment.

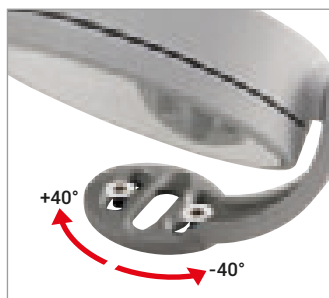

CLOCK

Spot per esterni
Outdoor spotlight



CLOCK ø 80 mm 220-250V

Code + Colour + Tonality

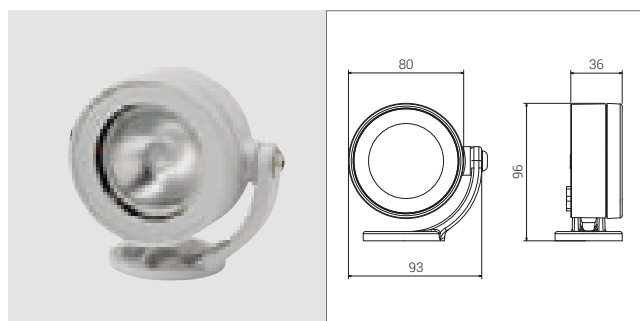

CODE	LAMP	W	lm Nominali-Real output	GM	GR
NEW 4661*	Led	4	480 300		

Alimentazione 220-250V con scheda Led a tensione di rete.

IP 67 / Classe I / IK 08

CRI 85 / Driver IN

230V / 50 Hz

CE

A richiesta versione a 24V DC o a corrente con driver remoto.

Tonalità 3000K o 4000K. Aggiungere 3K o 4K al codice dopo il colore.

220-250V power supply with a mains voltage LED.

IP 67 / Class I / IK 08

CRI 85 / Driver IN

230V / 50 Hz

CE

24V DC or constant current remote driver versions available **upon request**.

Color temperature available 3000K or 4000K. Add 3K or 4K to the code after the color.



option
aggiungere 12 al codice
add 12 to the code



standard



option
aggiungere 90 al codice
add 90 to the code



CLOCK ø 120 mm 220-250V

Code + Colour + Tonality

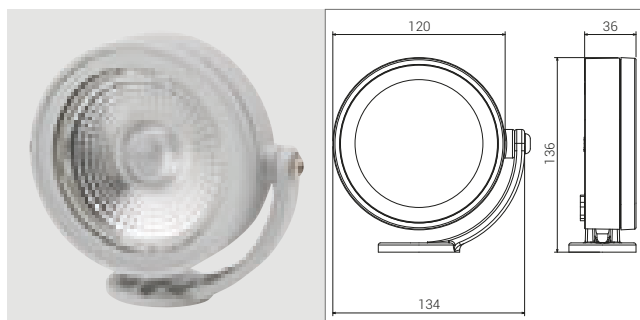

CODE	LAMP	W	lm Nominali-Real output	GM	GR
NEW 4664*	Led	10	1000 750		

Alimentazione 220-250V con scheda Led a tensione di rete.

IP 67 / Classe I / IK 08

CRI 85 / Driver IN

230V / 50 Hz

CE

A richiesta versione a corrente con driver remoto.

Tonalità 3000K o 4000K. Aggiungere 3K o 4K al codice dopo il colore.

220-250V power supply with a mains voltage LED.

IP 67 / Class I / IK 08

CRI 85 / Driver IN

230V / 50 Hz

CE

Constant current remote driver version available **upon request**.

Color temperature available 3000K or 4000K. Add 3K or 4K to the code after the color.



option
aggiungere 12 al codice
add 12 to the code



standard



option
aggiungere 90 al codice
add 90 to the code

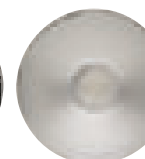



CLOCK

Spot per esterni
Outdoor spotlight

GIUNTI STAGNI | WATERTIGHT CONNECTION BLOCKS



CODE	DESCRIZIONE / DESCRIPTION
1941	Giunto di connessione IP68 per cavi 3x2,5 mm ² IP68 connection block for 3x2.5 mm ² cables



CODE	DESCRIZIONE / DESCRIPTION
1942	Giunto di connessione entra-esce per cavi 3x2,5 mm ² Through wiring connection block for 3x2.5 mm ² cables

PICCHETTO | SPIKE

Code + Colour

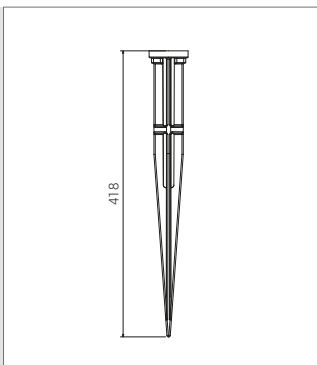

CODE	DESCRIZIONE / DESCRIPTION	GM	GR
NEW 4691*	Picchetto da giardino per \varnothing 80 e \varnothing 120 Garden spike for \varnothing 80 and \varnothing 120		

Policarbonato grigio. Altezza da terra consigliata: 10 cm come da normativa. Il cavo può passare nell'apposito foro della basetta e nella struttura del picchetto.

Grey polycarbonate. Recommended height above ground: 10 cm in compliance with regulations. The cable can pass through a special hole in the base and through the structure of the spike.

BRACCIO A MURO | WALL ARM

Code + Colour

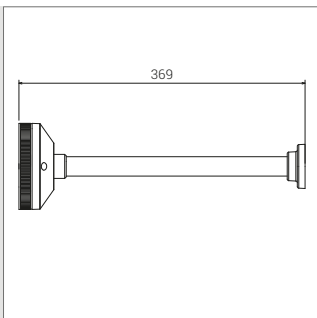
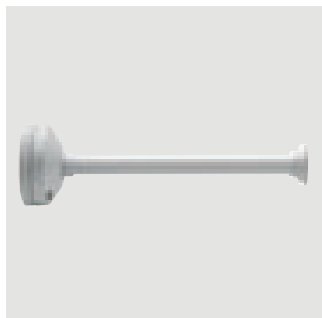

CODE	DESCRIZIONE / DESCRIPTION	GM
4692*	Braccio a muro per \varnothing 120 Wall arm for \varnothing 120	

Basetta e braccio in alluminio.

Aluminium base and arm.





STRIKE

PROIETTORI DA PARETE E DA TERRA WALL AND GROUND PROJECTORS

Con la serie STRIKE l'ambiente giardino si trasforma in un palcoscenico dove i giochi di luce creano un esclusivo effetto scenografico. La vasta gamma di accessori rende STRIKE installabile in un'incredibile varietà di posizioni: a parete, a terra, su paletto, a sbraccio; e in ogni ambiente: nei giardini, sopra le insegne, su un tronco o un ramo. I preziosi filtri dicroici colorano la luce con grande impatto emozionale. STRIKE è disponibile con una vasta gamma di sorgenti luminose: alogene a 230V, ioduri metallici da 70-150W. L'eccezionale sorgente Led, appositamente studiata per Goccia, vi stupirà con i suoi 9,5W e con la durata di 60.000 h. La grande STRIKE 2 si presenta invece con un potente gruppo Led da 29W e 3600 lumen.

With the STRIKE series, the garden is transformed into a stage where plays of light create a unique visual effect. The wide range of accessories allows for the installation of STRIKE in an incredible variety of positions: on the wall, on the ground, on a post, on an arm, anywhere. It can be installed in gardens, over signs, on tree trunks or branches. Precious dichroic filters create coloured light with captivating emotional impact. STRIKE is available in a wide range of lighting sources: 230V halogen, 70-150W metal halide lamps. The exceptional LED light source, which has been developed exclusively for Goccia, will surprise you with its performance of 9.5 W and a life of more than 60,000 hours. The large STRIKE 2 instead is provided with a powerful 29W and 3600 lumen LED unit.



STRIKE

Proiettori da parete e da terra
Wall and ground projectors

Designer: Carlo Vietri. Brevetto depositato
Designer: Carlo Vietri. Registered patent



Strike 1
LED



Strike 2
LED

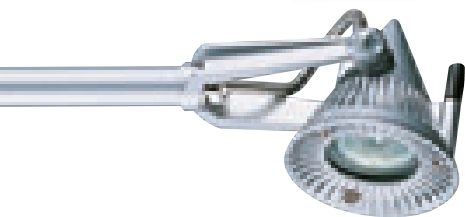



STRIKE

Proiettori da parete e da terra
Wall and ground projectors

CARATTERISTICHE GENERALI

- Apparecchio per esterno installabile a parete e a terra.
- **Struttura:** diffusore in vetro temprato trasparente e serigrafato. Corpo, basetta, forcella e cornice fermavetro in alluminio pressofuso a basso tenore di rame. Condotto flessibile in inox con passaguaina inox IP67.
- Sistema di snodo a scatti per l'orientamento sicuro del fascio luminoso.
- La versione con braccio in alluminio estruso (fornito già cablato), per l'installazione a parete o a terra, consente di allontanare il cono ottico dalla superficie di fissaggio.
- Ingresso cavi dal retro della basetta.
- Collegamento elettrico fra sorgente luminosa e basetta precablato di serie.
- **Sorgenti luminose** ad alta efficienza e basso consumo o Led di nuova generazione con vita garantita 60.000 h con successivo scadimento max del 20%. Driver incorporato.
- **Finitura:** su alluminio, decappaggio + fosfocromatazione + fondo epossidico + verniciatura con polveri epossidiche stabilizzate anti UV.
- Costruito in conformità alle norme europee EN 60598-1:2015 **CE**

STRUTTURA IN ALLUMINIO

- 1 - Guaina di protezione in acciaio inox
- 2 - Sistema di snodo a scatti
- 3 - Diffusore in vetro temprato
- 4 - Cono e forcella in alluminio pressofuso rivestito con vernice trasparente di protezione stabilizzata anti UV
- 5 - Base in alluminio con trasformatore, reattore e componenti elettrici

ALUMINIUM STRUCTURE

- 1 - Protection sleeve in stainless steel
- 2 - Adjustable locking device
- 3 - Tempered glass diffuser
- 4 - Die-cast aluminium cone and bracket fork with varnishing powder UV resistant finish
- 5 - Die-cast aluminium housing, control gear incorporated

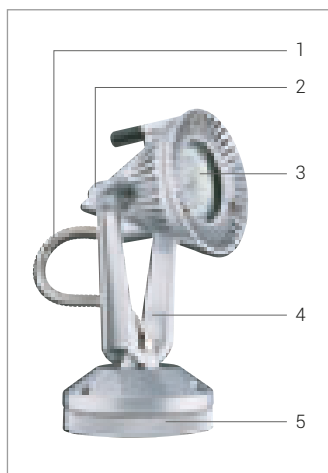

FASCIO LUMINOSO

Strike offre la scelta di 2 aperture del fascio luminoso: 18° e 38°.

ANGLE BEAM

Strike offers the choice of 2 angle beam openings: 18° and 38°.

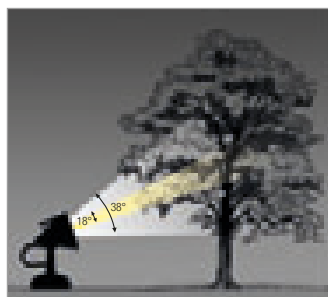

INSTALLAZIONE IN OGNI POSIZIONE

I numerosi accessori consentono l'installazione in ogni posizione.

INSTALLATION IN ANY POSITION

A large range of accessories allows the installation in any position.



GENERAL FEATURES

- Outdoor fitting for wall or ground installation.
- **Structure:** transparent and serigraph tempered glass diffuser. Low copper content die-cast aluminium body, base, bracket fork, and glazing bead frame. Flexible stainless steel duct with IP67 stainless steel cable housing.
- Adjustable locking system for safe angle beam orientation.
- The version with extruded aluminium arm (supplied pre-wired), for wall or ground installation, allows you to move the optical cone away from the fixing surface.
- Cable entry from the rear of the base.
- Electrical connection between light source and pre-wired standard base.
- High efficiency, low consumption **light sources** or new generation LEDs with minimum life 60,000 h with subsequent deterioration max 20%. Driver inside.
- **Finish:** on aluminium, pickling + phosphochrome + epoxy basic coating + UV resistant stabilised epoxy powder coating.
- Manufactured in compliance with European standards EN 60598-1:2015 **CE**

FILTRI DICROICI

Una serie di filtri dicroici colorati consentono di dare colore alla luce.

DICHROIC FILTERS

Available a full range of dichroic filters to colour the luminous beam.

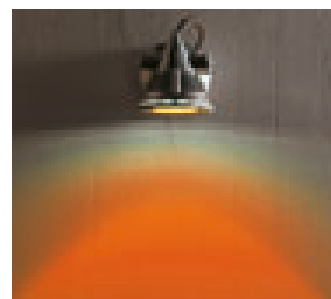

VERSIONE LED

Corpo illuminante con LED ad alta intensità di 9,5W e 1200 lumen.

LED VERSION

LEDs with special lens incorporated. 9,5W - 1200 Lumen - 60.000 hours.

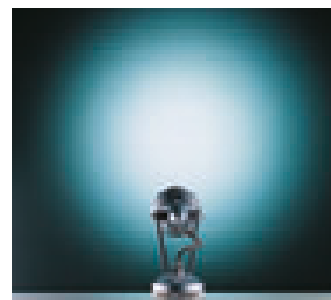

CORPO LAMPADA ORIENTABILE

Il corpo della lampada è orientabile a scatti con angolo di 15° per scatto.

ADJUSTABLE LAMP BODY

The optical cone can be oriented by 15 degrees.

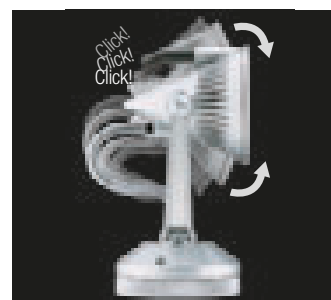

STRIKE 1

Proiettori da parete e da terra
Wall and ground projectors





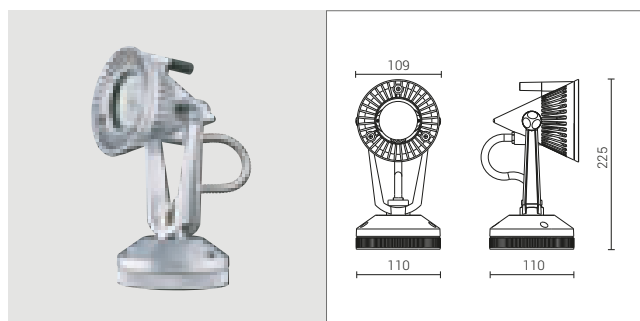

STRIKE 1





Code + Colour



CODE	LAMP	W	SI
------	------	---	----

4603*  Universale
GU 10 50

Lampadine non incluse.
IP 66  /  Classe II / IK 08
 

Lamps excluded.
IP 66  /  Class II / IK 08
 



Idoneo anche a questo tipo di lampadina
Alternative lamps allowed

Dimensioni massime della lampadina
Max. dimensions

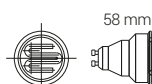

GU 10
fluorescente
fluorescent



GU 10
led

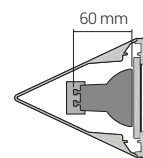



STRIKE 1 LED

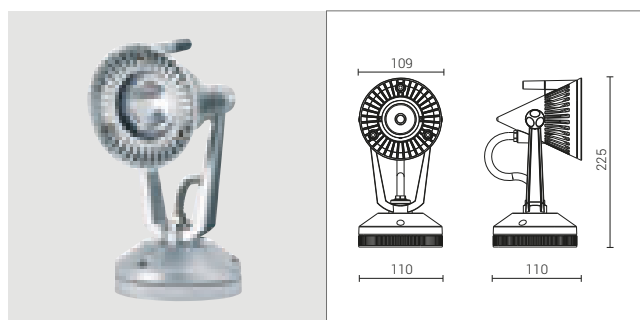

Code + Colour + Tonality



CODE	LAMP	W	lm Nominali-Real output	SI
------	------	---	-------------------------	----

4604*  Led 9,5 1200 703

Gruppo LED compreso.
Alimentazione 220-250V con alimentatore
elettronico incorporato nella base.
IP 66  /  Classe II / IK 08
CRI 85 / Driver IN / 350 mA
230V / 50 Hz
CE
Tonaltà 3000K o 4000K.
Aggiungere 3K o 4K al codice dopo il
colore.

LED unit included.
220-250V supply with electronic
transformer incorporated in the base.
IP 66  /  Class II / IK 08
CRI 85 / Driver IN / 350 mA
230V / 50 Hz
CE
Color temperature available 3000K or
4000K.
Add 3K or 4K to the code after the color.

 LED + parabola
LED + parabolic reflector



standard



option

aggiungere 38 al codice
add 38 to the code

STRIKE 1



STRIKE 1 CON BRACCIO DRITTO | STRIKE 1 WITH ARM

Code + Colour

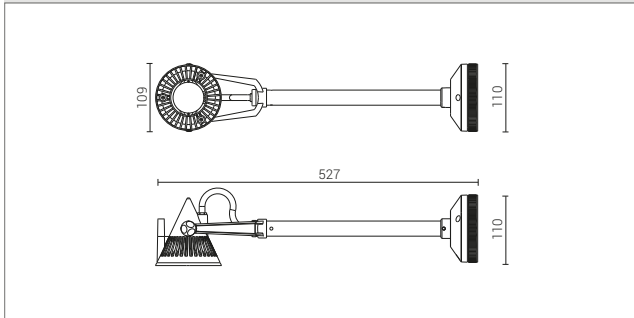

CODE	LAMP	W	SI
4607*	Universale GU 10	50	

Lampadine non incluse.
IP 66 / Classe II / IK 08
CE

Lamps excluded.
IP 66 / Class II / IK 08
CE



Idoneo anche a questo tipo di lampadina
Alternative lamps allowed

Dimensioni massime della lampadina
Max. dimensions

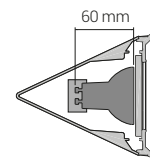
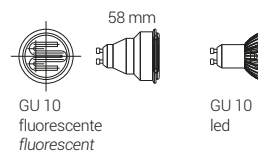

STRIKE 1 LED CON BRACCIO DRITTO | STRIKE 1 LED WITH ARM

Code + Colour + Tonality

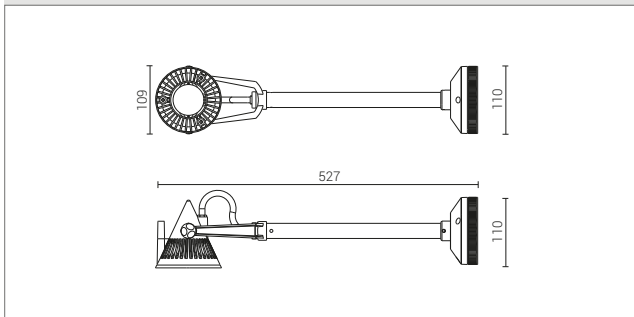
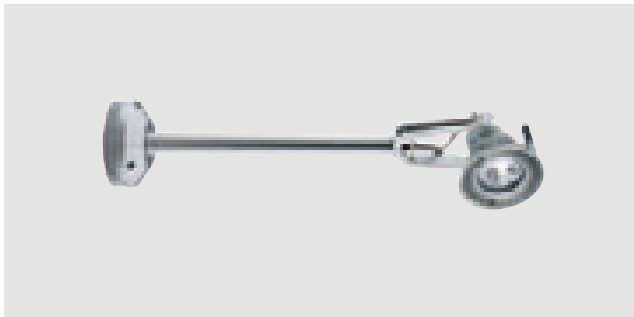

CODE	LAMP	W	lm Nominali-Real output	SI
4608*	Led	9,5	1200 703	

Gruppo LED compreso.
Alimentazione 220-250V con alimentatore elettronico incorporato nella base.
IP 66 / Classe II / IK 08
CRI 85 / Driver IN / 350 mA
230V / 50 Hz
CE

LED unit included.
220-250V supply with electronic transformer incorporated in the base.
IP 66 / Class II / IK 08
CRI 85 / Driver IN / 350 mA
230V / 50 Hz
CE

Tonalità 3000K o 4000K.
Aggiungere 3K o 4K al codice dopo il colore.

Color temperature available 3000K or 4000K.
Add 3K or 4K to the code after the color.

LED + parabola
LED + parabolic reflector



standard
option
aggiungere 38 al codice
add 38 to the code



STRIKE 1

Proiettori da parete e da terra
Wall and ground projectors

VISIERA | SHIELD

Code + Colour

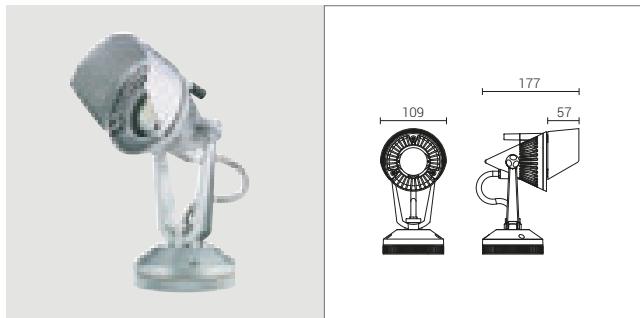

CODE DESCRIZIONE / DESCRIPTION

SI

4051* Visiera / Shield

Interamente in alluminio pressofuso.
Accessorio da montare successivamente
in ogni momento.
Solo visiera (apparecchio Strike a parte).

Entirely in die-cast aluminium.
Accessory to be installed afterwards at
any time.
Shield only (Strike fitting is supplied
separately).

FILTRO COLORE | DICHOIC FILTER

Code + Colour

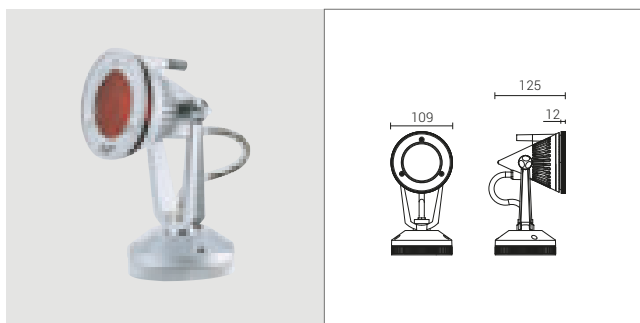

CODE DESCRIZIONE / DESCRIPTION

RO VE GI AR BL

4053* Filtro / Filter

In vetro borosilicato con trattamento
dicroico.
Completo di relativa cornice in alluminio
pressofuso.
Solo filtro (apparecchio Strike a parte)
Filtro + visiera possibili con viti speciali.

Pirex glass and dichroic finish.
With frame in die-cast aluminium.
Filter only (Strike fitting is supplied
separately).
Shield and filter can be installed together
with special screws.

PICCHETTO | SPIKE

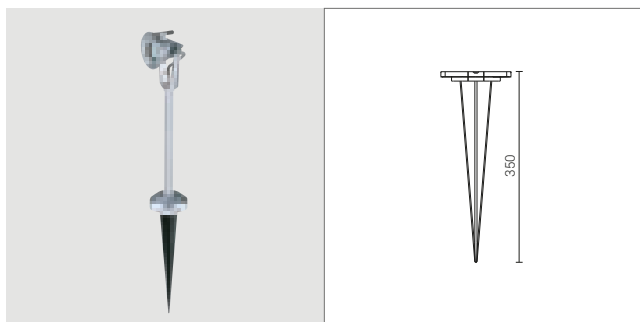

CODE DESCRIZIONE / DESCRIPTION

4055 Picchetto / Spike

Interamente in materiale plastico.
Per cod. 4603/4604/4607/4608.
Solo picchetto (apparecchio Strike a
parte).

Entirely in no corrosion tecnopolimer.
To be installed with codes
4603/4604/4607/4608.
Spike only (Strike fitting is supplied
separately).

PIASTRA E CINGHIA | PLATE AND STRAP

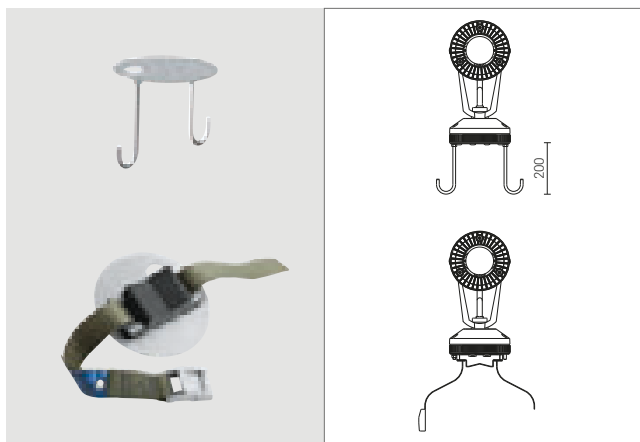

CODE DESCRIZIONE / DESCRIPTION

4057 Piastra con tirafondi / Plate with anchoring set

Piastra in acciaio inox 304 con tirafondi
per ancoraggio al terreno.
Per cod. 4603/4604/4607/4608.

Stainless-steel plate with ground
anchoring set.
To be installed with codes
4603/4604/4607/4608.

CODE DESCRIZIONE / DESCRIPTION

4059 Cinghia / Strap

Cinghia per applicazione su rami, tronchi,
pali, colonne, max \varnothing 15 cm.
Completa di cinghia, staffa, guarnizione
Per cod. 4603/4604.
Solo cinghia (apparecchio Strike a parte)

Strap for installation on branches,
stumps, poles, columns, max \varnothing 15 cm.
With strap, bracket, gasket.
To be installed with codes 4603/4604.
Strap only (Strike fitting is supplied
separately).

STRIKE 2

Proiettori da parete e da terra
Wall and ground projectors

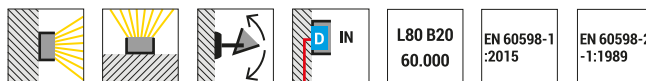

STRIKE 2

Code + Colour

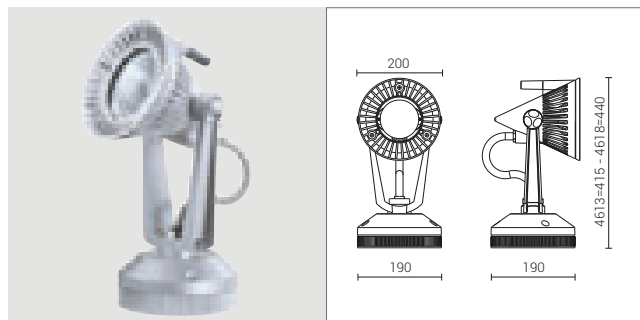

CODE	LAMP	W	SI
4613*	Ioduri metallici Metal halide G 12	70	
4618*	Ioduri metallici Metal halide G 12	150	

Gruppo di alimentazione contenuto nella basetta.
Apertura del fascio regolabile mediante variatore esterno.
Lampadine non incluse.
IP 66 / Classe II / IK 08

Control gear incorporated in the base.
Adjustable angle beam by external device.
Lamps excluded.
IP 66 / Class II / IK 08

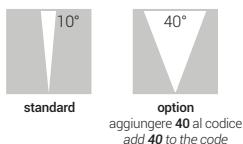
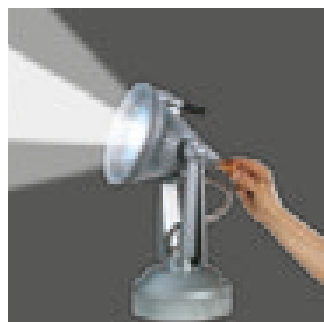

STRIKE 2 LED

Code + Colour + Tonality

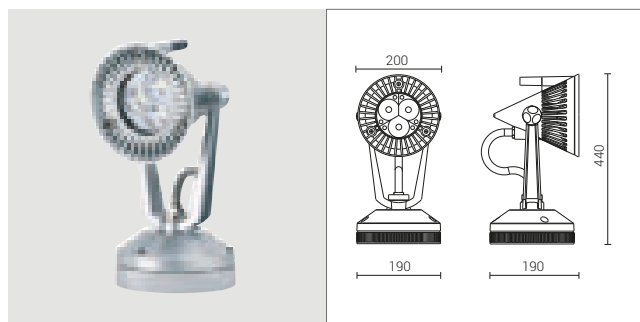

CODE	LAMP	W	Im Nominali-Real output	SI
4614*	Led	29	3600 2294	

Alimentazione 230V con driver incorporato.
Gruppo da 3 Led.
IP 66 / Classe II / IK 08
CRI 85 / Driver IN / 500 mA
230V / 50 Hz
CE
Tonalità 3000K o 4000K.
Aggiungere 3K o 4K al codice dopo il colore.

Driver 220-250V incorporated.
3 Led.
IP 66 / Class II / IK 08
CRI 85 / Driver IN / 500 mA
230V / 50 Hz
CE
Color temperature available 3000K or 4000K.
Add 3K or 4K to the code after the color.

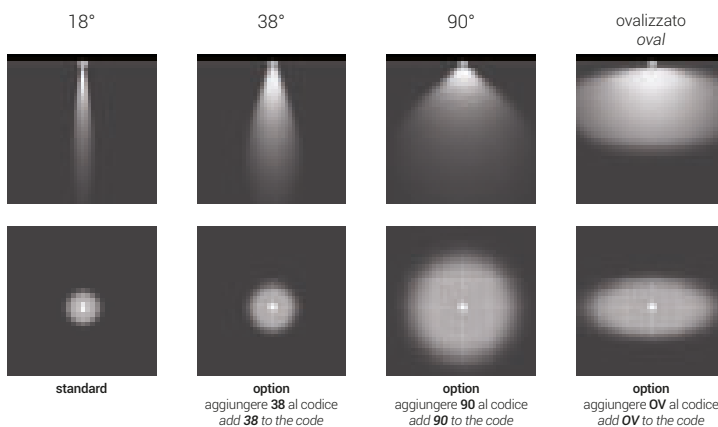

STRIKE 2

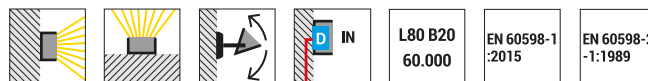

STRIKE 2 CON BRACCIO DRITTO | STRIKE 2 WITH ARM

Code + Colour

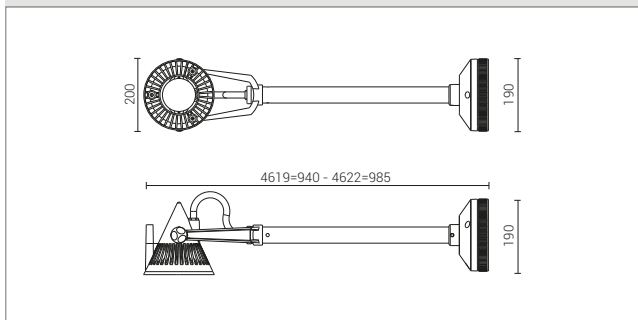

CODE	LAMP		W	SI
4619*	Ioduri metallici Metal halide	G 12	70	
4622*	Ioduri metallici Metal halide	G 12	150	

Gruppo di alimentazione contenuto nella basetta.
Lampadine non incluse.
IP 66 / Classe II / IK 08

*Control gear incorporated in the base.
Lamps excluded.*
IP 66 / Class II / IK 08

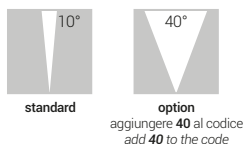

STRIKE 2 LED CON BRACCIO DRITTO | STRIKE 2 LED WITH ARM

Code + Colour + Tonality

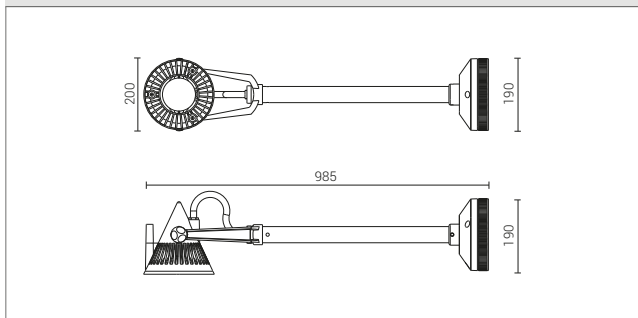

CODE	LAMP	W	lm Nominali-Real output	SI
4623*	Led	29	3600 2294	

Alimentazione 230V con driver incorporato.
Gruppo da 3 Led.
IP 66 / Classe II / IK 08
CRI 85 / Driver IN / 500 mA
230V / 50 Hz
CE
Tonalità 3000K o 4000K.
Aggiungere 3K o 4K al codice dopo il colore.

*Driver 220-250V incorporated.
3 Led.*
IP 66 / Class II / IK 08
CRI 85 / Driver IN / 500 mA
230V / 50 Hz
CE
Color temperature available 3000K or 4000K.
Add 3K or 4K to the code after the color.

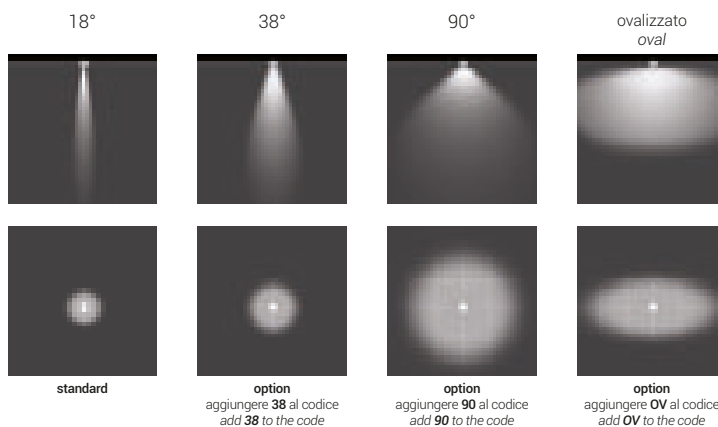

GIOIELLERIA



OTTICA



STRIKE 2

Proiettori da parete e da terra
Wall and ground projectors

VISIERA | SHIELD

Code + Colour

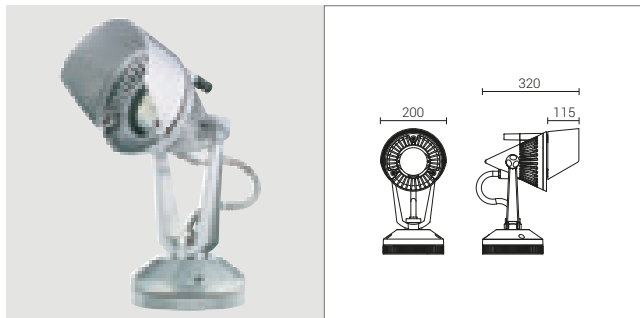

CODE DESCRIZIONE / DESCRIPTION

SI

4652* Visiera / Shield

Interamente in alluminio pressofuso.
Accessorio da montare successivamente
in ogni momento.
Solo visiera (apparecchio Strike a parte).

Entirely in die-cast aluminium.
Accessory to be installed afterwards at
any time.
Shield only (Strike fitting is supplied
separately).

FILTRO COLORE | DICHOIC FILTER

Code + Colour



CODE DESCRIZIONE / DESCRIPTION

RO VE GI AR BL

4654* Filtro / Filter

In vetro borosilicato con trattamento
dicroico.
Completo di relativa cornice in alluminio
pressofuso.
Solo filtro (apparecchio Strike a parte)
Filtro + visiera possibili con viti speciali.

Pirex glass and dichroic finish.
With frame in die-cast aluminium.
Filter only (Strike fitting is supplied
separately).
Shield and filter can be installed together
with special screws.

PICCHETTO | SPIKE

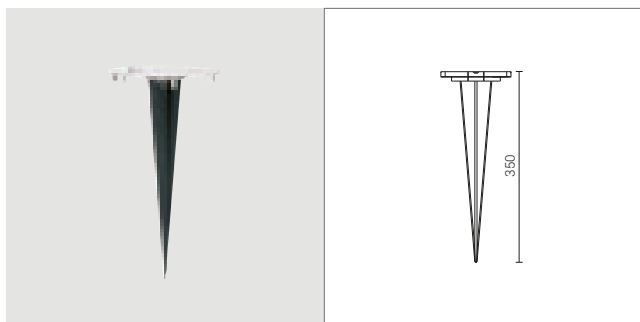

CODE DESCRIZIONE / DESCRIPTION

4655 Picchetto / Spike

In materiale plastico con staffa in acciaio.
Per cod. 4613/4618/4614.
Solo picchetto (apparecchio Strike a
parte).

In no corrosion tecnopolimer + steel
bracket.
To be installed with codes
4613/4618/4614.
Spike only (Strike fitting is supplied
separately).

PIASTRA | PLATE



CODE DESCRIZIONE / DESCRIPTION

4656 Piastra con tirafondi / Plate with anchoring set

Piastra in acciaio inox 304 con tirafondi
per ancoraggio al terreno.
Per cod. 4613/4618/4614/4619/4622/
4623.

Stainless-steel plate with ground
anchoring set.
To be installed with codes
4613/4618/4614/4619/4622/4623.



LUX SHOWER

DOWNLIGHT



Lux Shower



Lux Shower Led

LED

Nata per offrire una forte illuminazione che scende dall'alto, LUX SHOWER è la soluzione ideale. È stagna ed è stata progettata per l'installazione a soffitto con elevatissima resa luminosa. Il riflettore in alluminio brillantato 99,8, frutto di un sofisticato studio ottico, consente un rendimento del 70%. Il particolare meccanismo interno di regolazione permette la variazione del fascio luminoso su 3 angoli: 30, 60 e 90°. Il corpo in alluminio, il vetro temperato e la costruzione stagna garantiscono la tenuta IP65.

LUX SHOWER it's the ideal solution when the light comes from an high ceiling. The parabolic reflector inside guarantees high efficiency – 70% - and permits to regulate and adjust its lighting angle beam -30°-60°-90° in the same fixture. The housing in primary die-cast aluminium, the tempered glass, the silicon gaskets make the fixture suitable IP 65 index.



LUX SHOWER

Downlight

CARATTERISTICHE GENERALI

- Apparecchio per esterni per installazione a soffitto.
- **Struttura:** diffusore in vetro temprato. Corpo lampada, basetta e cornice fermavetro in alluminio pressofuso a basso tenore di rame. Vasta gamma di aperture del fascio luminoso tramite parabole in Al 99,8 dopo ossidazione anodica ed ottiche Led dedicate.
- Ingresso cavi dal retro.
- **Sorgenti luminose** ad alto rendimento e basso consumo o Led di nuova generazione con vita garantita 60.000 h con successivo scadimento max del 20%. Driver incorporato.
- **Finitura:** su alluminio, decappaggio + fosfocromatazione + fondo epossidico + verniciatura con polveri epossidiche stabilizzate anti UV.
- Costruito in conformità alle norme europee EN 60598-1:2015 **CE**

GENERAL FEATURES

- *Outdoor ceiling installation fitting.*
- **Structure:** tempered glass diffuser. Low copper content die-cast aluminium lamp body, base, and glazing bead frame. Wide range of angle beam openings via Al 99.8 parabolics after anodic oxidation and special LED optics.
- Cable entry from the back.
- High performance, low consumption **light sources** or new generation LEDs with minimum life 60,000 h with subsequent deterioration max 20%. Driver inside.
- **Finish:** on aluminium, pickling + phosphochrome + epoxy basic coating + UV resistant stabilised epoxy powder coating.
- *Manufactured in compliance with European standards EN 60598-1:2015 **CE***

FASCI LUMINOSI

L'apparecchio consente di sistemare la lampadina in 3 posizioni diverse, permettendo di ottenere 3 diversi fasci luminosi: 30°, 60° e 90°.
Nella versione a led le sofisticate lenti in resina purissima consentono 4 diverse aperture del fascio luminoso.

ANGLE BEAMS

The lampholder is suitable to be fixed in three different positions for three different lighting angle beams. Thanks to the pure optical lens inside the power led version offers a wide range of interesting angle beams.

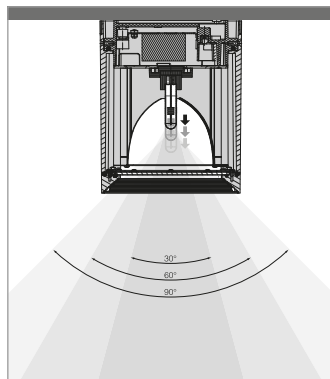

ALTA RESA LUMINOSA

Riflettore in Al 99,8 lucido frutto di progetto illuminotecnico per ottimizzare il rendimento luminoso.

HIGH LIGHTING EFFICIENCY

Al 99,8 polished reflector to enhance the lighting efficiency.



LED DI POTENZA

Led di potenza da 6,5 W ciascuno - 1980 lumen totali.

POWER LED

New generation power led 6,5W each - 1980 lumen totally.





LUX SHOWER

Downlight



LUX SHOWER

Code + Colour

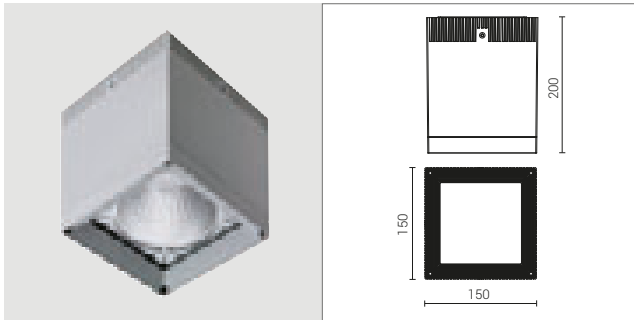

CODE	LAMP	W	GR	GM	BI
1085*	Ioduri metallici Metal halide GU 6,5	20			
1086*	Ioduri metallici Metal halide GU 6,5	35			

Alimentazione 230V con reattore elettronico incorporato.
Apertura del fascio regolabile 30°-60°-90°.
Rendimento di cod. 1085-1086 73/72/68% per 90/60/30°.
Lampadine non incluse.
IP 65 / Classe II / IK 08
230V / 50 Hz
€

*Electronic ballast inside for 20W and 35W metal halide.
Adjustable angle beam regulation 30°-60°-90°.
Codes 1085/1086 efficiency: 73/72/68% for 90/60/30°.
Lamps excluded.
IP 65 / Class II / IK 08
230V / 50 Hz
€*

LUX SHOWER LED

Code + Colour + Tonality

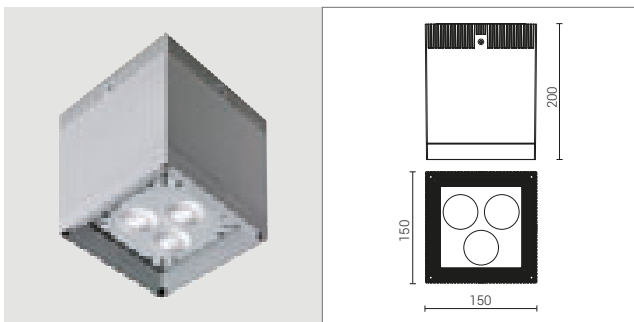

CODE	LAMP	W	Im Nominali-Real output	GR	GM	BI
1087*	Led	3X6,5	1980 1764			

Alimentazione 230V con driver incorporato.
3 gruppi Led.
IP 65 / Classe II / IK 08
CRI 85 / Driver IN / 350 mA
230V / 50 Hz
€
Tonalità 3000K o 4000K.
Aggiungere 3K o 4K al codice dopo il colore.

*3 led units, 230V driver inside.
IP 65 / Class II / IK 08
CRI 85 / Driver IN / 350 mA
230V / 50 Hz
€
Color temperature available 3000K or 4000K.
Add 3K or 4K to the code after the color.*

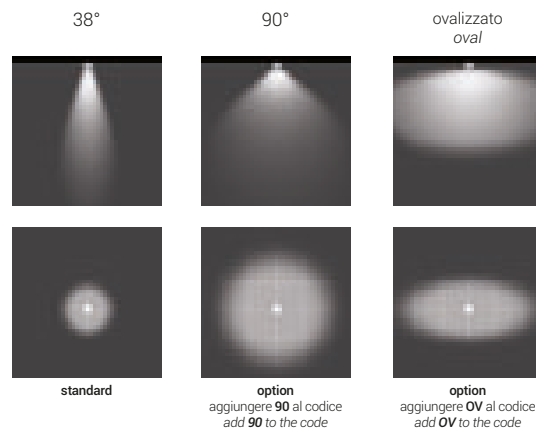



LUX SHOWER INSIDE

DOWNLIGHT



LUX SHOWER INSIDE è una nuova generazione di lampade da incasso a soffitto. Nata per risolvere l'illuminazione dall'alto, con la possibilità di basculaggio e orientamento del corpo illuminante a Led o basso consumo, permette di risolvere le più particolari esigenze di illuminazione esterna in loggati, corridoi, portici. Il sistema di ganci di fissaggio precablati consente di installare le lampade su controsoffitti da 5 a 50 mm e, con la versione Ultraflat, anche in spazi limitati. Le particolarità costruttive consentono di garantire perfetta tenuta stagna, resistenza alla corrosione,.

LUX SHOWER INSIDE is a new generation of recessed ceiling lamps. Designed to illuminate from above, with tilting and LED or energy saving lamps. Ideal for particular lighting needs in open galleries, corridors, and arcades. The pre-wired fastening hooks allow for lamp installation on false ceilings from 5 to 50 mm and, with the Ultraflat version, also in areas with limited space. Its special constructive features ensure perfect sealing and corrosion resistance.



LUX SHOWER INSIDE

Downlight

CARATTERISTICHE GENERALI

- Serie da incasso a soffitto.
- **Struttura:** corpo lampada in alluminio primario a basso contenuto di rame, verniciato con polveri poliestere anticorrosione dopo fosfocromatazione. Disponibile in 4 diametri: \varnothing 70, 125, 180 e 245 mm forniti con flange di chiusura in alluminio (flange INOX tonde o quadrate a richiesta).
- Vetro temperato trasparente o opale a richiesta con $T \leq 40^\circ\text{C}$; spessore da 6 a 12 mm.
- Fornito con 0,5 m di cavo H07RN-F e giunto di connessione IP68.
- Installabili su controsoffitti con spessori da 5 a 50 mm mediante ganci di fissaggio in acciaio in dotazione.
- Versione \varnothing 125 ultraflat a basso spessore con vetro opale.
- **Sorgenti luminose** a basso consumo e a Led da 3, 4, 8, 9,5 e 29 W con CRI 80 e vita garantita 60.000 h con decremento max del 20% - L80 B20.
- Driver remoto per cod. 1470, incorporato per tutti gli altri.
- Ottica fissa per cod. 1470, basculante $\pm 15^\circ$ per cod. 1473, 1474, 1475 e $\pm 25^\circ$ per cod. 1476.
- Costruito in conformità alle norme europee EN 60598-1:2015 **CE**

GENERAL FEATURES

- Series for recessed ceilings.
- **Structure:** lamp body in low copper content primary aluminium with pre-phosphochrome corrosion protection polyester powder coating. Available in 4 diameters: 70, 125, 180 and 245 mm supplied with aluminium closing flanges (round or square stainless steel flanges upon request).
- Transparent tempered glass, opal upon request, with $T \leq 40^\circ\text{C}$, thickness from 6 to 12 mm.
- Supplied with 0.5 m of cable H07RN-F and IP68 coupling.
- Can be installed on false ceilings with thickness from 5 to 50 mm with supplied steel fastening hooks.
- Ultraflat diam. 125 version with opal glass.
- Low consumption **light sources** and 3, 4, 8, 9.5 and 29 W LEDs with CRI 80 and minimum life 60,000 h with subsequent deterioration max 20% - L80 B20.
- Remote driver 1470, inside for all others.
- Fixed optics for code 1470, tilting $\pm 15^\circ$ for codes 1473, 1474, 1475 and $\pm 25^\circ$ for code 1476.
- Manufactured in compliance with European standards EN 60598-1:2015 **CE**

STAFFE DI FISSAGGIO

Staffe di fissaggio già incluse e cablate. Avvitando le viti di bloccaggio in senso orario si dispongono nella posizione di aggancio fino a serrare l'apparecchio al controsoffitto. Per fissaggio su spessori da 5 a 50 mm.

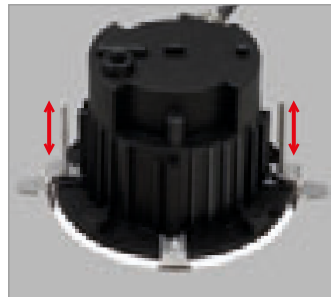

FASTENING BRACKETS

Fastening brackets already included and wired. Tighten the locking screws in the clockwise direction to arrange the hooking position until the fitting is secured to the false ceiling. For fastening on thicknesses from 5 to 50 mm.

OTTICA BASCULANTE E ROTANTE

L'ottica delle lampade è basculabile per $\pm 15^\circ/25^\circ$ (escluso $\varnothing 70$) e ruota sul piano orizzontale per un corretto posizionamento del fascio luminoso.

ADJUSTABLE AND ROUTABLE OPTIC

Fully adjustable optic (unless for \varnothing 70 mm). Vertically $\pm 15^\circ$ for \varnothing 125 and 180 mm and $\pm 25^\circ$ for \varnothing 245 mm. Horizontally for the right firing.

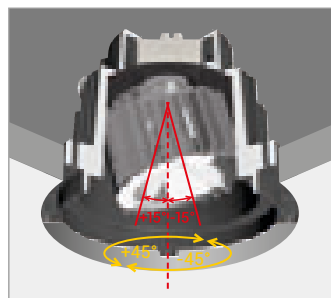

CAVO E GIUNTO IP68

Tutti i corpi lampade sono precablati con 0,5 m di cavo H07RN-F e giunto di connessione IP68.

IP68 WIRING

Any fitting of the range is pre-wired with 0,5 mt H07RN-F cable and connection block IP 68.



LUX SHOWER INSIDE

Downlight



L80 B20
60.000

EN 60598-1
:2015

EN 60598-2
:2012

CORPO LAMPADA | LIGHT BODY \varnothing 70 mm

Code + Colour + Tonality

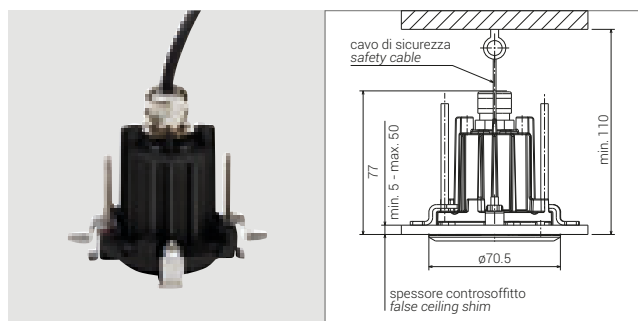

Foro controsoffitto
False ceiling hole
 \varnothing min. 65 mm - \varnothing max. 66 mm
Flange in alluminio fornite.
A richiesta flangia inox 316L tonda o quadra.
Aluminium flanges provided.
Round or square 316L stainless steel flange on request.

CODE	LAMP	W	lm	Nominali-Real output	GM
1470*	○ Led	3/24V DC	185	101	

Ottica fissa. Driver OUT funzionante a 24V DC per collegamento in parallelo. A richiesta versione a corrente/dimmerabile o flange inox.
Vetro trasparente 6 mm.
IP 67 con flange / Classe III \diamond / IK 08
CRI 80 / Driver OUT / 24V DC
CE

Tonalità 3000K o 4000K. Aggiungere 3K o 4K al codice dopo il colore.

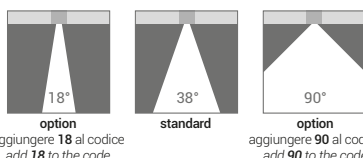

Fixed optic. Driver OUT 24V DC working and parallel connection. On request constant current version/dim or 316L covers.
Clear glass 6 mm.
IP 67 with flanges / Class III \diamond / IK 08
CRI 80 / Driver OUT / 24V DC
CE
Color temperature available 3000K or 4000K. Add 3K or 4K to the code after the color.

CORPO LAMPADA | LIGHT BODY \varnothing 125 mm

Code + Colour + Tonality

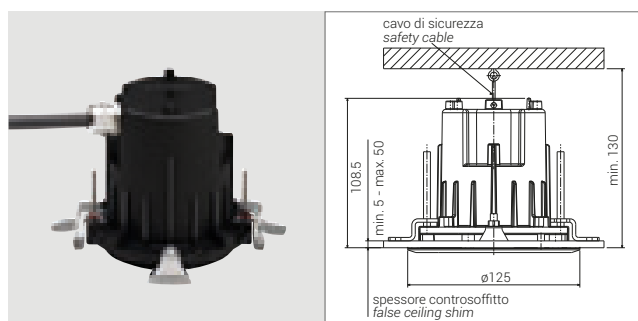

Foro controsoffitto
False ceiling hole
 \varnothing min. 115 mm - \varnothing max. 116 mm
Flange in alluminio fornite.
A richiesta flangia inox 316L tonda o quadra.
Aluminium flanges provided.
Round or square 316L stainless steel flange on request.

CODE	LAMP	W	lm	Nominali-Real output	GM
1472*	○ Led	4/230V	410	256	
1473*	⤵ GU 10	L max 57mm	5/230V		

Ottica basculante $\pm 15^\circ$ per cod.1472, $\pm 8^\circ$ per cod.1473.

Vetro trasparente 10 mm.
Cod.1473 fornito senza lampadina.
IP 67 con flange / Classe I / IK 10
CRI 80 / Driver IN / 350 mA
230V / 50 Hz / 24V DC a richiesta
CE

Tonalità 3000K o 4000K. Aggiungere 3K o 4K al codice dopo il colore.

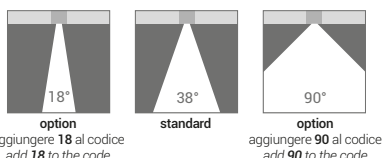

Fully adjustable optic $\pm 15^\circ$ for code 1472, $\pm 8^\circ$ for code 1473.

Clear glass 10 mm.
Code1473 supplied without lamp.
IP 67 with flanges / Class I / IK 10
CRI 80 / Driver IN / 350 mA
230V / 50 Hz / 24V DC on request
CE
Color temperature available 3000K or 4000K. Add 3K or 4K to the code after the color.

CORPO LAMPADA ULTRAFLAT | ULTRAFLAT LIGHT BODY \varnothing 125 mm

Code + Colour + Tonality

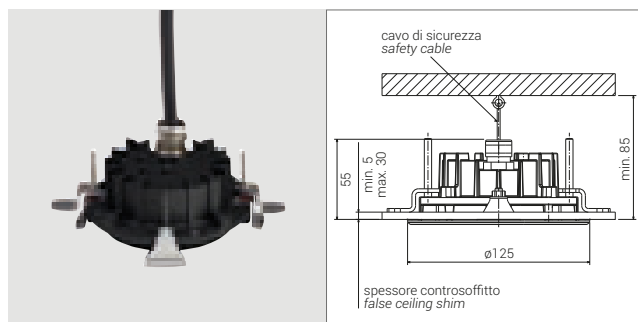

Foro controsoffitto
False ceiling hole
 \varnothing min. 115 mm - \varnothing max. 116 mm
Flange in alluminio fornite.
A richiesta flangia inox 316L tonda o quadra.
Aluminium flanges provided.
Round or square 316L stainless steel flange on request.

CODE	LAMP	W	lm	Nominali-Real output	GM
1479*	○ Led	8/230V	800	355	

Ottica fissa.
Vetro opale 10 mm.
IP 67 con flange / Classe I / IK 10
CRI 80 / Driver IN / 350 mA
230V / 50 Hz
CE

Tonalità 3000K o 4000K. Aggiungere 3K o 4K al codice dopo il colore.

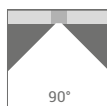

Fixed optic.
Opal glass 10 mm.
IP 67 with flanges / Class I / IK 10
CRI 80 / Driver IN / 350 mA
230V / 50 Hz
CE
Color temperature available 3000K or 4000K. Add 3K or 4K to the code after the color.

LUX SHOWER INSIDE



CORPO LAMPADA | LIGHT BODY ϕ 180 mm

Code + Colour + Tonality

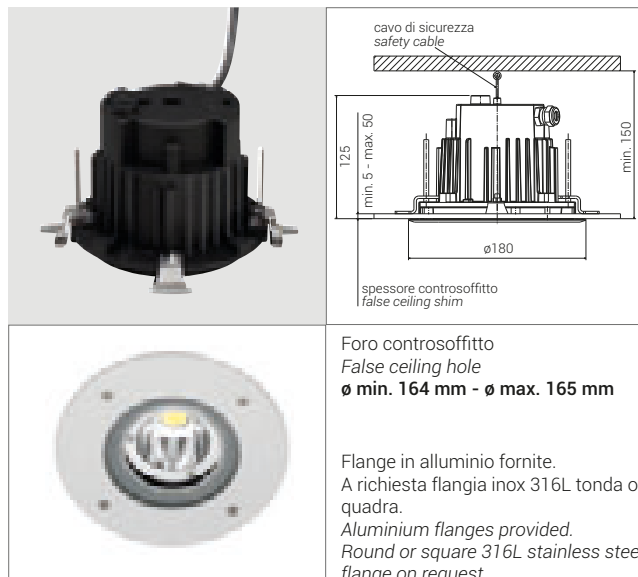

CODE	LAMP	W	lm Nominali-Real output	GM
1474*	○ Led	9,5/230V	1200 806	

Ottica basculante $\pm 15^\circ$.
Vetro trasparente 12 mm.
Versione antiscivolo a richiesta.
IP 67 con flange / Classe I / IK 10
CRI 80 / Driver IN / 350 mA
230V / 50 Hz / 24V DC a richiesta
CE

Fully adjustable optic $\pm 15^\circ$.
Clear glass 12 mm.
Skidproof glass on request.
IP 67 with flanges / Class I / IK 10
CRI 80 / Driver IN / 350 mA
230V / 50 Hz / 24V DC on request
CE
Color temperature available 3000K or 4000K. Add 3K or 4K to the code after the color.

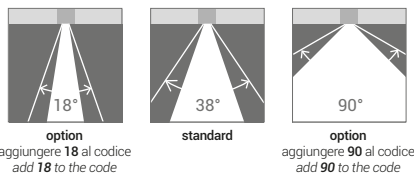

CORPO LAMPADA | LIGHT BODY ϕ 245 mm

Code + Colour + Tonality



CODE	LAMP	W	lm Nominali-Real output	GM
1476*	○ Led	29/230V	3600 2294	
1477*	— Ioduri Metallici Metal Halide	70/230V		
1478*	□ E27	L max 195	30/230V	

Ottica basculante $\pm 25^\circ$.
Vetro trasparente 12 mm.
Cod. 1477/1478 forniti senza lampadina.
IP 67 con flange / Classe I / IK 10
CRI 80 / Driver IN / 350 mA
230V / 50 Hz
CE

Adjustable optic $\pm 25^\circ$.
Clear glass 12 mm.
Code 1477/1478 supplied without lamp.
IP 67 with flanges / Class I / IK 10
CRI 80 / Driver IN / 350 mA
230V / 50 Hz
CE
Color temperature available 3000K or 4000K. Add 3K or 4K to the code after the color.

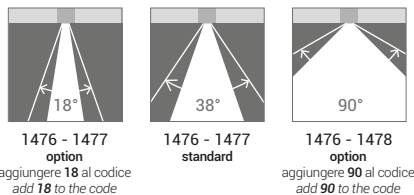

ALIMENTATORI 24V DC PER COLLEGAMENTO IN PARALLELO 24V DC DRIVER FOR PARALLEL CONNECTION

CODE	Volt DC	W	IP	Dimensioni - Dimensions mm
1952	24	18	67	120 x 30 x 22
1954	24	35	67	148 x 40 x 30
1955	24	60	67	162.5 x 42.5 x 32



RGB LED

CONTROLLO DEL COLORE DELLA LUCE
CONTROLLING THE COLOUR OF LIGHT



Generatore
monocanale DMX
DMX Signal Generator



RGBW K³
LED



RGBW Strike 2
LED



RGBW Passum
LED

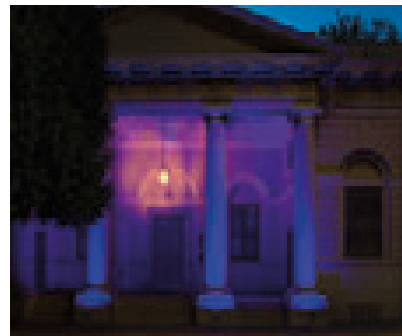
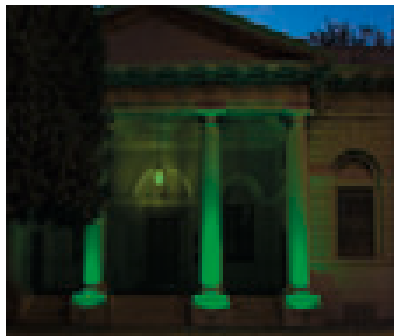
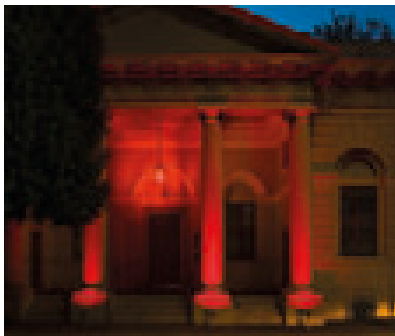

Il sistema RGBW Goccia, comandato da centralina remota attraverso un segnale trasmesso con protocollo DMX 512 Standard, consente di programmare i Led RGB e miscelare i colori, ma contiene pure il quarto colore bianco: è un sistema RGB+BIANCO. Il sistema RGBW Goccia è composto dagli apparecchi K³, Strike 2 e Passum dotati di dispositivo per ricevere il segnale, e dal Generatore di segnale remoto, che permette di eseguire diverse funzioni: scelta del colore; dimmerazione dell'intensità della luce; rotazione dei colori; passaggio al bianco puro; regolazione della tonalità di luce da 2700K fino a 6000K. Il sistema è ideale per l'installazione su facciate di edifici (hotels, palazzi storici ed arredi urbani) dove le cromie luminose esaltano l'architettura delle strutture.

The Goccia system, thanks to a touch screen Signal Generator in DMX protocol, permits to schedule and mix the colors, but offers also the fourth color pure white. That's why the system is RGBW (+white). The lighting fittings K³, Strike 2 and Passum contain a PCB capable to receive the signal coming from the generator and perform the following functions by touch screen: choice of the color; colors rotation; transition to pure white; dim the light intensity; tonality regulation from 2700K to 6000K. Ideal for building facades (hotels, historic buildings and urban areas) where the colors accent the architectural aspect.



RGB LED

Controllo del colore della luce
Controlling the colour of light

CARATTERISTICHE GENERALI

- Apparecchi RGBW per esterni in DMX 512 standard.
- **Struttura:** entrambi gli apparecchi sono in alluminio pressofuso a basso tenore di rame. Per informazioni sulla struttura, vedi **Serie K³ Writer, Strike 2 e Passum Up**.
- Gli apparecchi contengono: la scheda RGBW con circuito integrato in grado di interfacciarsi con il segnale DMX 512 standard, il trasformatore di alimentazione.
- Il generatore di segnale DMX può essere installato a incasso o su scatola sporgente e consente la regolazione di tutti gli apparecchi mediante un unico canale.
- **Funzioni:** scelta del colore; dimmerazione dell'intensità della luce; rotazione dei colori; passaggio al bianco puro; regolazione della tonalità di luce da 2700K fino a 6000K.
- **Sorgenti luminose** a Led di nuova generazione suddivise in 4 settori RGBW. Vita garantita 60.000 h con successivo scadimento max del 20%.
- **Finitura:** su alluminio, decappaggio + fosfocromatazione + fondo epossidico + verniciatura con polveri epossidiche stabilizzate anti UV.
- Costruito in conformità alle norme europee EN 60598-1:2015 **CE**

GENERAL FEATURES

- *Outdoor RGBW fittings in standard DMX 512.*
- **Structure:** both fittings are low copper content die-cast aluminium. For information regarding the structure, see **K³ Writer, Strike 2 and Passum Up Series**.
- *Fittings contain: RGBW board with built-in circuit able to interface with standard DMX 512 signal, the power transformer.*
- *DMX signal generator can be installed recessed or on a protruding box and allows the user to regulate all fittings on a single channel.*
- **Functions:** choice of the colour, dimming of light intensity, colour rotation, transition to pure white, tonality regulation from 2700K up to 6000K.
- *New generation LED light sources divided into 4 RGBW sectors. Minimum life 60,000 h with subsequent deterioration max 20%.*
- **Finish:** on aluminium, pickling + phosphochrome + epoxy basic coating + UV resistant stabilised epoxy powder coating.
- *Manufactured in compliance with European standards EN 60598-1:2015 **CE***

RGBW CENTRALINA

Il sistema Goccia, comandato da centralina remota attraverso un segnale trasmesso con protocollo DMX 512 Standard, è composto dagli apparecchi **K³, Strike 2 e Passum Up** dotati di dispositivo per ricevere il segnale, e dal **Generatore di segnale remoto**, che permette di eseguire diverse funzioni.

RGBW SIGNAL GENERATOR

The Goccia system, controlled from the remote control unit through a signal transmitted via Standard DMX 512 protocol, is composed of **K³, Strike 2 and Passum Up** fittings equipped with a device for signal receipt, and of a **Remote signal generator** which allows for the implementation of various functions.

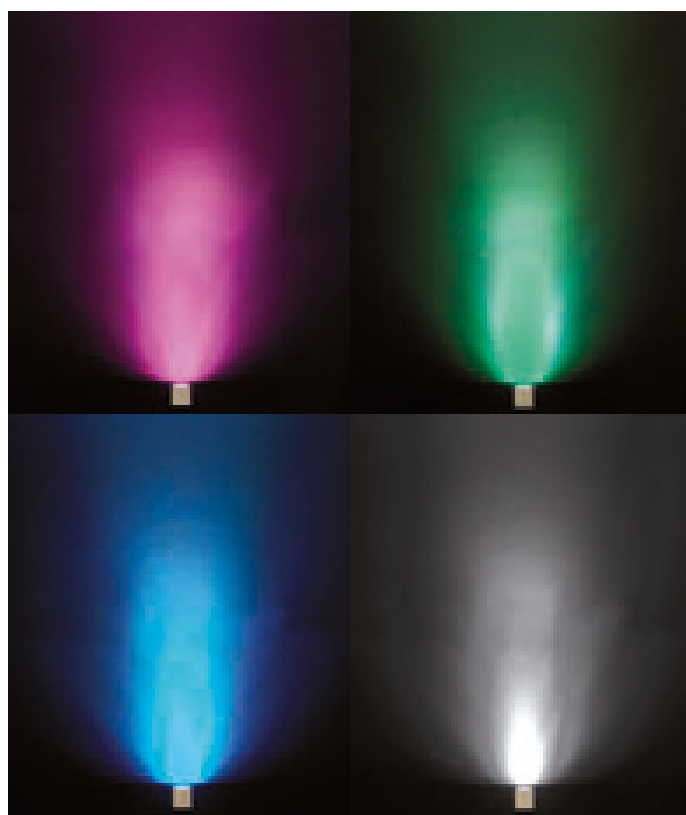
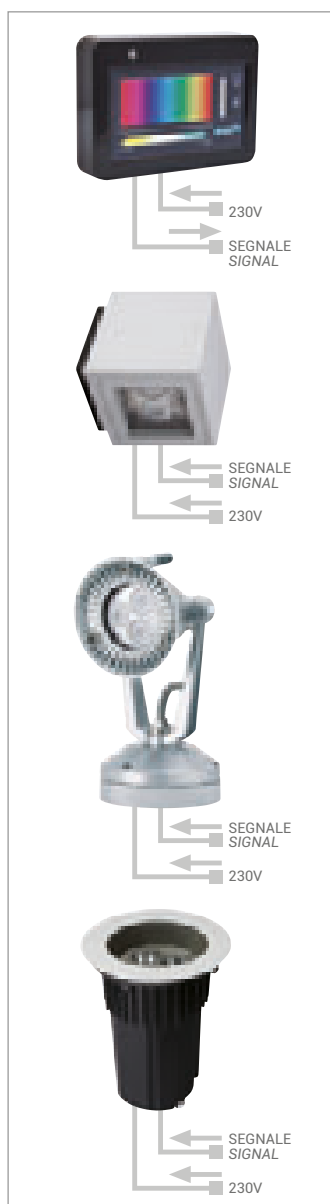

AMPIA GAMMA DI COLORI

È possibile ottenere una vastissima gamma di colori oltre alla possibilità di dimmerazione e regolazione della tonalità di bianco.

WIDE RANGE OF COLOURS

You can get a wide range of colors, dim the light and regulate the white tonality.

RGB LED

Controllo del colore della luce
Controlling the colour of light

RGBW CENTRALINA | RGBW SIGNAL GENERATOR

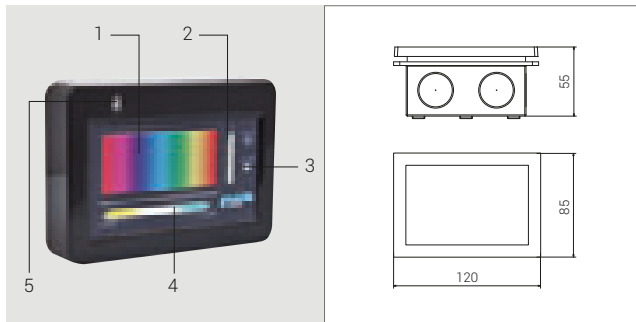

- 1 - Spettro colori
- 2 - Intensità
- 3 - Rotazione colori
- 4 - Regolazione tonalità della luce bianca
- 5 - Led illustrativo del comando impartito

- 1 - Colors range
- 2 - Light Dim
- 3 - Colors rotation
- 4 - White tonality regulation
- 5 - Led illustrating the function

CODE DESCRIZIONE / DESCRIPTION

1180 Centralina compatibile con gli apparecchi 1184, 1188 e 1482
Uni-channel DMX 512 standard signal generator

Generatore monocanale di segnale DMX 512 Standard con comandi touch screen per pilotare il sistema RGBW (+ bianco) degli apparecchi Goccia K³ 1184, Strike 2 1188 e Passum Up 1482.

Tutti gli apparecchi collegati alla centralina emettono contemporaneamente lo stesso colore. Funzioni: scelta colore / dimmerazione touch screen / rotazione colori / 4° colore bianco / regolazione della tonalità di luce da 2700K a 6000K.

Presenza di un Led di segnalazione che identifica il significato del comando senza dover vedere il risultato sugli apparecchi.

Emissione segnale fino alla distanza max di 300 m per un max di n° 32 apparecchi collegati con appropriato cavo per DMX. Per distanze superiori il segnale va amplificato con adeguato ripetitore/ amplificatore di segnale DMX Standard 512.

Alimentazione 230V; contiene trasformatore 230V/24V. Completo di scatola per incasso a muro.

Touch screen uni-channel DMX 512 standard signal generator, capable to drive the fittings 1184, 1188 and 1482 to the system RGBW (+white).

The fittings connected will emit all together the same color.

Functions: color choice / color rotation / pure white fourth color / Dim the light / white tonality regulation from 2700K to 6000K.

A signal led shows color and function of the system. You don't need to check the results on the fittings.

Max. of 32 fittings until 300m with the appropriate DMX cable.

For longer distances or signal missing use a relevant signal amplifier. 230V power, transformer 230V/24V inside.

Complete with its backbox to recess in the wall. On request a backbox for surface mount.

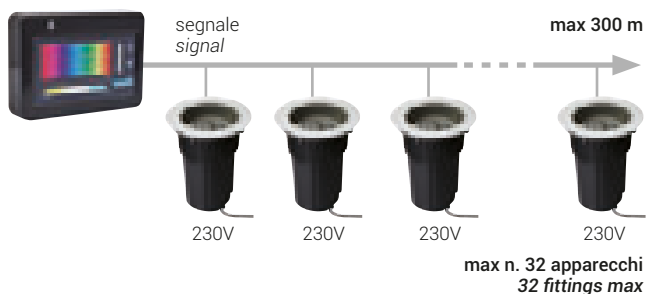
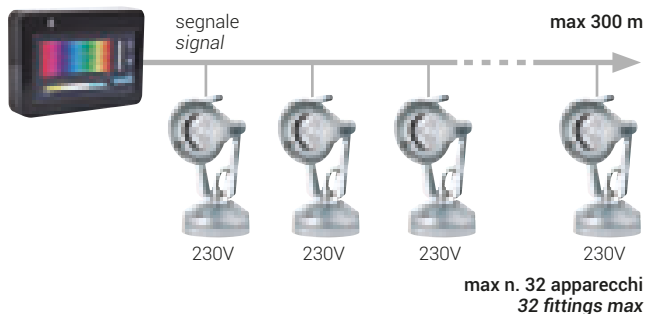
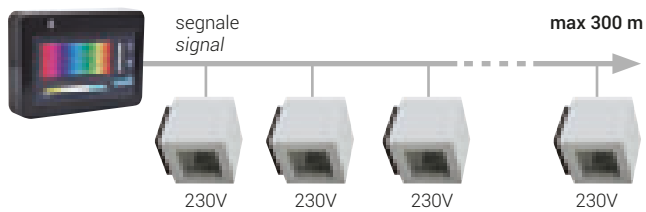

SISTEMA DI CABLAGGIO | WIRING SYSTEM

La direttiva RS485-DX indica il metodo di cablaggio, il tipo di cavo e di morsetteria per una corretta trasmissione del segnale. Gli apparecchi Goccia contengono Led RGB + Bianco e apparato per ricevere segnale monocanale DMX standard 512 inviato da Centralina monocanale Goccia 1180 o altra centralina pluricanale compatibile. La centralina Goccia 1180 invece trasmette segnale DMX 512 su un unico canale.

The standard RS485-DX prescribes the wiring system. It concerns the type of cables, terminal blocks, etc. for a correct DMX 512 standard signal transmission. Please refer to this standard. The Goccia fittings 1184-1188-1482 contain RGBW Leds and the PCB capable to receive the signal by the generator 1180, but can receive also DMX signal by other multi-channel DMX generators.

RGB LED



RGBW K³

Code + Colour

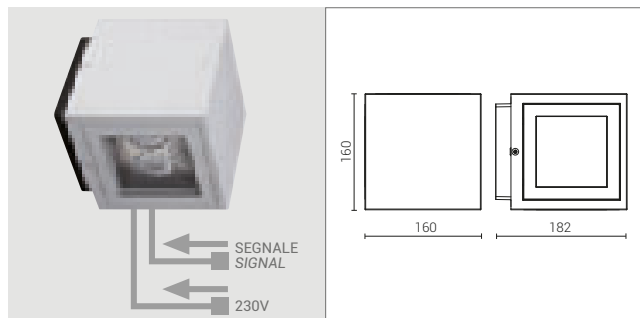

CODE	LAMP	W	lm Nominali-Real output	GR	GM	BI
1184*	Led RGBW	20	525 244			

Stessa struttura dell'apparecchio K³.
Emissione luce da 1 faccia.
Contiene 3 Led RGBW (+ bianco) e apparato per ricevere il segnale monocanale DMX standard 512 inviato dalla Centralina monocanale Goccia 1180 o altra centralina compatibile.
Apertura del fascio: 40°.
Sono collegabili fino a 32 apparecchi per ogni centralina cod. 1180; tutti gli apparecchi emettono la stessa tonalità ed intensità luminosa.
L'articolo 1184 contiene il dispositivo per l'identificazione del singolo apparecchio in modo da ricevere anche segnali multicanale da apposite centraline compatibili.
IP 65 / Classe I / IK 08
Driver IN
CE

Same structure as K³ fitting. Light emission from 1 window. Contains 3 RGBW (+white) LED and a fitting for receiving the uni-channel standard DMX 512 signal sent from the Goccia 1180 uni-channel control unit or another compatible unit.
Beam opening: 40°.
Can connect to up to 32 fittings for each code 1180 control unit. All fittings emit the same tonality and light intensity.
Item 1184 contains a device for identifying individual fittings so as to also receive multi-channel signals from compatible control units.
IP 65 / Class I / IK 08
Driver IN
CE

RGBW STRIKE 2

Code + Colour

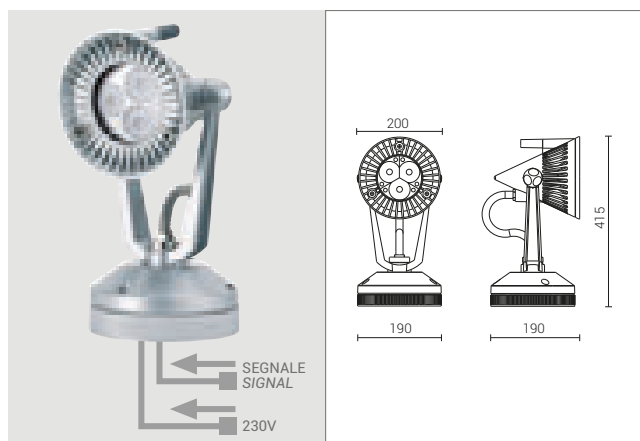

CODE	LAMP	W	lm Nominali-Real output	SI
1188*	Led RGBW	20	525 244	

Stessa struttura dell'apparecchio Strike 2.
Stesse prestazioni dell'art. 1184.
L'articolo 1188 contiene il dispositivo per l'identificazione del singolo apparecchio in modo da ricevere anche segnali multicanale da apposite centraline compatibili.
IP 66 / Classe I / IK 08
Driver IN
CE

Same housing as Strike2.
Same performances as code 1184.
The identification system inside allows to emit single different color for each fitting (with the use of a different multi-channel signal generator).
IP 66 / Class I / IK 08
Driver IN
CE

RGBW PASSUM UP ø 245 mm

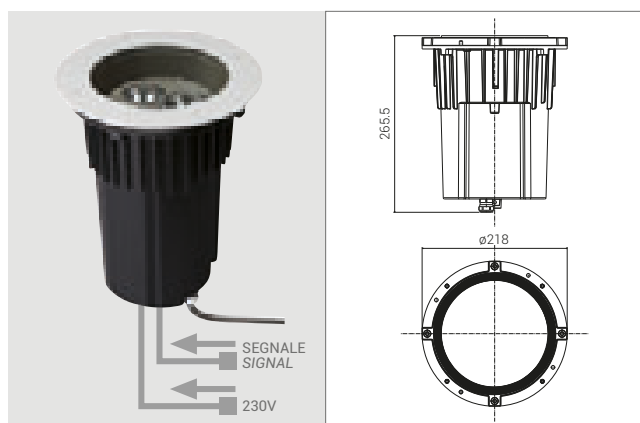

CODE	LAMP	W	lm Nominali-Real output
1482	Led RGBW	20	525 244

Stessa struttura dell'apparecchio Passum Up RGBW.
Stesse prestazioni dell'art. 1184.
L'articolo 1482 contiene il dispositivo per l'identificazione del singolo apparecchio in modo da ricevere anche segnali multicanale da apposite centraline compatibili.
IP 67 con flange / Classe I / IK 10
CRI 80 / Driver IN / 350 mA / RGBW
230V / 50 Hz
CE

Same housing as Passum Up RGBW.
Same performances as code 1184.
The identification system inside allows to emit single different color for each fitting (with the use of a different multi-channel signal generator).
IP 67 with flanges / Class I / IK 10
CRI 80 / Driver IN / 350 mA / RGBW
230V / 50 Hz
CE

Flangia di chiusura non compresa: vedi pag. 66.
Covering flange not included: see page 66.



TRIALO

Designer: Stefano Anconetani

PROIETTORI DA PARETE E DA TERRA WALL AND GROUND PROJECTORS



Trialo

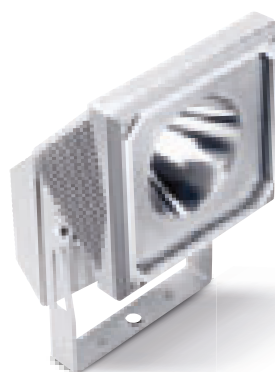

Trialo Led
LED



CARATTERISTICHE GENERALI

- Proiettore per esterni ad alto rendimento.
- **Struttura:** diffusore in vetro temprato trasparente o opale. Corpo lampada, scatola di cablaggio e cornice fermavetro in alluminio pressofuso a basso tenore di rame
- Orientabile in tutte le direzioni.
- Ottiche performanti in Al 99,8 brillantato. Sono previste varie aperture del fascio luminoso.
- Ingresso cavi nell'apposita scatola di cablaggio.
- Installabile a parete o da terra in giardino.
- **Sorgenti luminose:** ad alta efficienza e basso consumo o potente Led di nuova generazione con vita garantita 60.000 h con successivo scadimento max del 20%. Driver incorporato.
- **Finitura:** su alluminio, decappaggio + fosfocromatazione + fondo epossidico + verniciatura con polveri epossidiche stabilizzate anti UV.
- Costruito in conformità alle norme europee EN 60598-1:2015 **CE**

GENERAL FEATURES

- High performance outdoor floodlight.
- **Structure:** transparent or opal tempered glass diffuser. Low copper content die-cast aluminium lamp body, wiring box, and glazing bead frame.
- Adjustable in all directions.
- High performance Al 99.8 polished optics. Various angle beam openings available.
- Cable entry in the corresponding wiring box.
- Can be installed on walls or on the ground in gardens.
- High efficiency, low consumption **light sources** or powerful new generation LEDs with minimum life 60,000 h with subsequent deterioration max 20%. Driver inside.
- **Finish:** on aluminium, pickling + phosphochrome + epoxy basic coating + UV resistant stabilised epoxy powder coating.
- Manufactured in compliance with European standards EN 60598-1:2015 **CE**



FERME
NO CONTINUITO
DALLA LINEA
ALTA MODA

FERME
PARRUCCHIERI

FERME
PARRUCCHIERI

TRIALO

Proiettori da parete e da terra
Wall and ground projectors

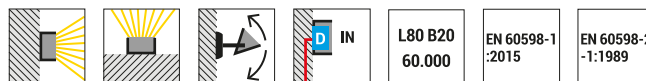

L80 B20
60.000

EN 60598-1
:2015

EN 60598-2
-1:1989

TRIALO

Code + Colour

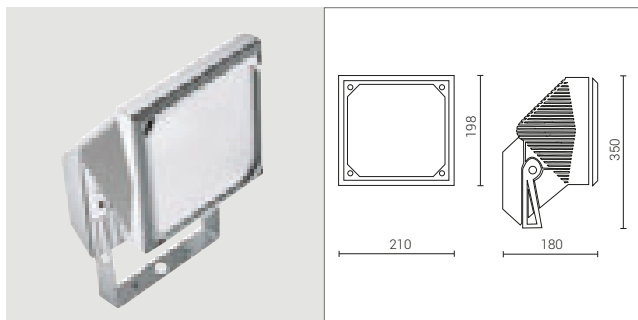

CODE	LAMP	W	NE	SI
------	------	---	----	----

4633* Alimentaz. elettronica Gx24q-3
Electronic ballast

2x26

Diffusore in vetro temprato opale.
IP 65 \blacklozenge \blacktriangle \blacktriangle / Classe I / Esecuzione in
classe II \square a richiesta / IK 08
CE

Opal tempered glass diffuser.
IP 65 \blacklozenge \blacktriangle \blacktriangle / Class I / Class II \square on
request / IK 08
CE

TRIALO LED

Code + Colour + Tonality

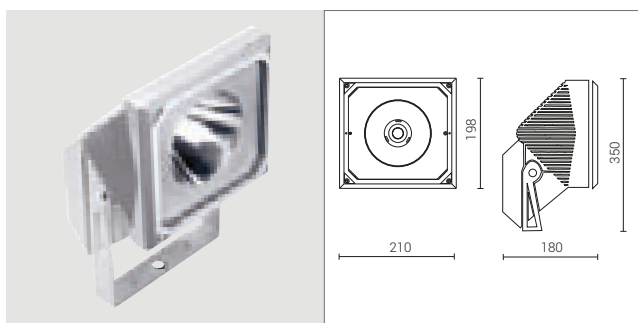

CODE	LAMP	W	Im Nominali-Real output	NE	SI
------	------	---	-------------------------	----	----

4675*

● Led

29,3

4000 2574

Diffusore in vetro temprato trasparente.
IP 65 \blacklozenge \blacktriangle \blacktriangle / Classe I / IK 08
CRI 80 / Driver IN
230V / 50 Hz
CE

Tonalità 3000K o 4000K. Aggiungere 3K
o 4K al codice dopo il colore.

Clear tempered glass diffuser.
IP 65 \blacklozenge \blacktriangle \blacktriangle / Class I / IK 08
CRI 80 / Driver IN
230V / 50 Hz
CE

Color temperature available 3000K or
4000K. Add 3K or 4K to the code after
the color.



option

aggiungere 18 al codice
add 18 to the code



standard



DOCKS

PLAFONIERE APPLIQUES WALL/CEILING MOUNT

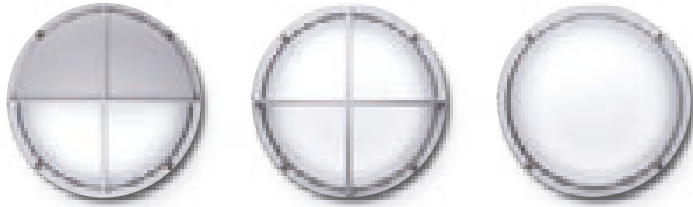

Alluminio marino
Marine Aluminium

LED



Inox AISI 316L
AISI 316L Stainless Steel

LED



Ottone
Brass

LED

La Serie DOCKS reinterpreta gli apparecchi di uso e gusto navale utilizzandone i materiali tipici: acciaio inox AISI 316L, alluminio marino e ottone 60/40. Riproposte nelle classiche forme griglia, senza griglia e palpebra, sono ideali per l'installazione in esterni particolarmente esposti alla corrosione. Il design classico, la nobiltà e la resistenza dei materiali ne fanno la lampada ideale per architetture in ambiente marino.

With DOCKS Goccia Illuminazione reinterprets naval Luminaries with their typical look of installation on board. The materials as well are the same: AISI 316L Stainless Steel, marine Aluminium and 60/40 Brass. The range belongs to the classic idea of the Goccia catalogue: with eyelid, with guard and without guard. The look, the materials nobility make DOCKS ideal for marine architectural environments. Docks comes now in a new version power Led inside. A new generation power Led of 1420 lumen.

Tutta la funzionalità di Docks Led | *The complete Docks Led versatility*

DOCKS LED LUCE STANDARD | *DOCKS LED NORMAL LIGHT*

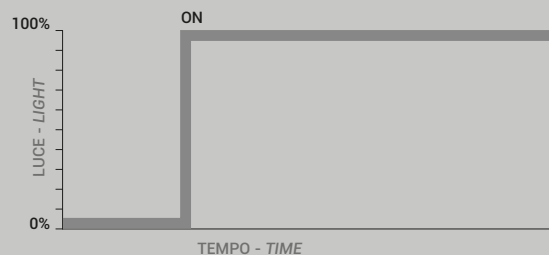
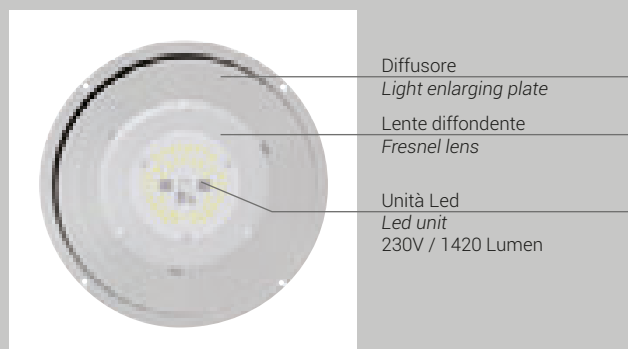

Unità Led da 1420 Lumen, 230 V. Accensione immediata. 14W consumo. Durata 50.000 h con decremento max del 20%. Driver non necessario.

Led unit 1420 lumen / 230V. Instant lighting on. 14W / 50.000 hours life with max decreasing of 20%. Driver not necessary.

DOCKS LED LUCE STANDARD + EMERGENZA | *DOCKS LED MAINTAINED LIGHTING (NORMAL LIGHT + EMERGENCY)*

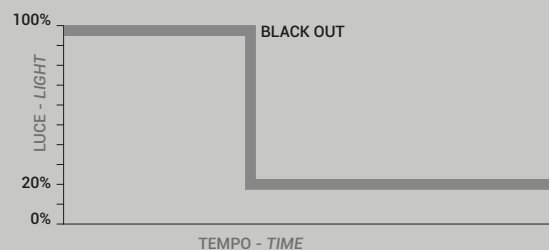
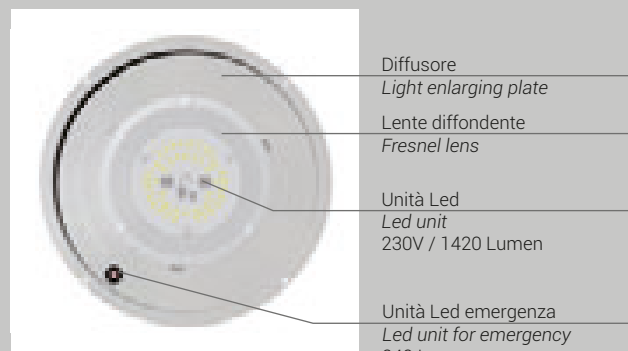

Funzionamento in S.A. (sempre accesa) innesto automatico dell'emergenza. Unità Led emergenza da 240 Lumen. Durata 3 h.

Light always on - under power or in emergency - Automatic lighting on under batteries. 240 lumen in emergency / 3 hours life

DOCKS LED ILLUMINAZIONE INTELLIGENTE | *DOCKS LED INTELLIGENT ILLUMINATION*

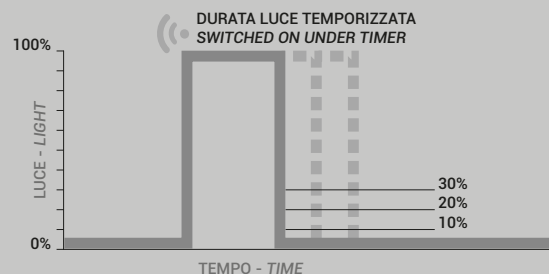
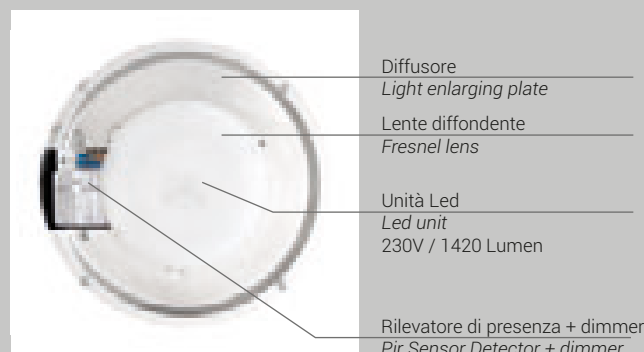

Illuminazione intelligente: regolazione a 0/10/20/30% della luce notturna tramite dimmer interno. Accensione a luce piena tramite rilevatore di presenza. Tre regolazioni: area rilevatore, temporizzazione, luce crepuscolare.

Intelligent illumination: adjustable night light to 0/10/20/30% by a dimmer inside and light on to 100% when the Pir Sensor detects people in the area. Three regulations: area, timer, daylight.

DOCKS

Plafoniere appliques
Wall/ceiling mount

CARATTERISTICHE GENERALI

- Plafoniera per esterno in Alluminio, Inox e Ottone.
- **Struttura:** diffusore in vetro opale stampato, policarbonato opale IK 10 per antivandalo. Guarnizioni di tenuta in silicone. Corpo in: alluminio pressofuso a basso tenore di rame, inox AISI 316L, ottone. Base in alluminio pressofuso. Piattello interno reggicablaggio in Al 99,8 con ingresso cavi dal retro. Viti inox.
- **Sorgenti luminose** ad alto rendimento e basso consumo o Led di nuova generazione con vita garantita 50.000 h con successivo scadimento max del 20%. Driver incorporato.
- **Emergenza:** per basso consumo SA 1h/3h; per Led SA 3h.
- **Illuminazione intelligente:** per l'applicazione a Led sono disponibili le varianti con "illuminazione intelligente" (0-10-20-30% in stato di quiete con accensione automatica al 100% al passaggio) o per "emergenza SA" sempre accesa.
- **Finitura.** Per l'alluminio: decappaggio + fosfocromatazione + fondo epossidico + verniciatura con polveri epossidiche stabilizzate anti UV. Per l'inox: spazzolato e lucidato. Per l'ottone: spazzolato e lucidato.
- Costruito in conformità alle norme europee EN 60598-1:2015 CE

GENERAL FEATURES

- *Outdoor ceiling light in Aluminium, Stainless steel, and Brass.*
- **Structure:** moulded opal glass, IK 10 vandalproof polycarbonate diffuser. Silicone sealing gaskets. Body in: low copper content die-cast aluminium or AISI 316L stainless steel, brass. Aluminium die-cast base. Internal wire holder plate in Al 99.8 with cable entry from the back. Stainless steel screws.
- *High performance, low consumption light sources or new generation LEDs with minimum life 50,000 h with subsequent deterioration max 20%. Driver inside.*
- **Emergency:** for energy savings SA 1h/3h; for LED SA 3h.
- **Intelligent illumination:** variations for "intelligent illumination" (0-10-20-30% night light with automatic ignition at 100% when sensor detects people in the area) available for LED application or for "SA emergency" (light always on).
- **Finish.** For aluminium: pickling + phosphochrome + epoxy basic coating + UV resistant stabilised epoxy powder coating. For stainless steel: brushed and polished. For brass: brushed and polished.
- *Manufactured in compliance with European standards EN 60598-1:2015 CE*



UNA COMPLETA COMPONENTISTICA

- 1 - Base in alluminio marino
- 2 - Dissipatore di calore
- 3 - Piattello Led
- 4 - Riflettore in alluminio brillantato 99,8%
- 5 - Guarnizioni in silicone
- 6 - Vetro stampato o coppa in policarbonato antivandalo
- 7 - Rivestimento in inox AISI 316L, alluminio marino, ottone 60/40

COMPLETE COMPONENTS

- 1 - Base in marine aluminium
- 2 - Heat sink
- 3 - Led unit and its plate
- 4 - Al 99,8 polished reflector
- 5 - Silicon gaskets
- 6 - Opal glass or vandalproof polycarbonate diffuser
- 7 - External body in AISI 316L stainless steel, marine aluminium, brass 60/40

ALLUMINIO MARINO

Alluminio marino con viti inox. Stabilità assoluta. Verniciatura poliesteri dopo fosfocromatazione stabilizzata anti UV.

MARINE ALUMINIUM

Marine aluminium + stainless steel screws. Corrosion + UV resistant. Peculiar anti-corrosion resistant typical of primary aluminium.



ACCIAIO INOX AISI 316L

Acciaio inox AISI 316L con viti inox. Maschera tornita da lastra. Finitura: spazzolata e satinata.

AISI 316L STAINLESS STEEL

AISI 316L Stainless Steel. Brushed and thin satined. Stainless Steel screws.



OTTONE 60/40

Ottone 60/40 con viti ottone. Soggetto a naturale brunitura tipica del materiale e successiva stabilizzazione.

BRASS 60/40

Brass 60/40. In the time brass will achieve towards browning, typical evolution of the material. Brass screws.



DOCKS

Plafoniere appliques
Wall/ceiling mount



DOCKS ALLUMINIO | DOCKS ALUMINIUM

Emergenza: SA 1h/3h.
IP 66 / Classe I / IK 08 - IK 10
CE

Emergency: maintained lighting 1h/3h.
IP 66 / Class I / IK 08 - IK 10
CE

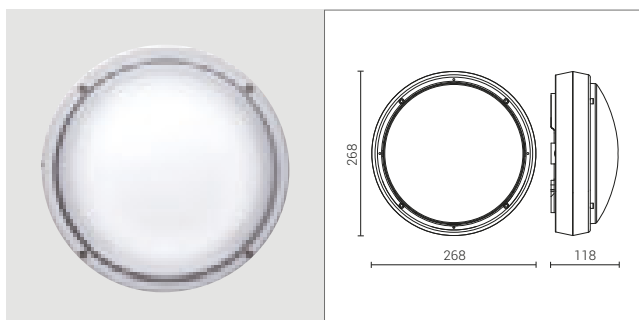

CODE	LAMP		W	GR	GM	BI
9000*	E27	L max 180mm	75			
9001*	G23		2x9			
9002*	G24d-3		26			
4400*	Emergenza Emergency	2G7	2x9			



Antivandalo | Vandalproof

Code + Colour

CODE	LAMP		W	GR	GM	BI
9060*	E27	L max 180mm	75			
9061*	G23		2x9			
9062*	G24d-3		26			
4460*	Emergenza Emergency	2G7	2x9			

CODE	LAMP		W	GR	GM	BI
9005*	E27	L max 180mm	75			
9006*	G23		2x9			
9007*	G24d-3		26			
4402*	Emergenza Emergency	2G7	2x9			



Antivandalo | Vandalproof

Code + Colour

CODE	LAMP		W	GR	GM	BI
9064*	E27	L max 180mm	75			
9065*	G23		2x9			
9066*	G24d-3		26			
4461*	Emergenza Emergency	2G7	2x9			

CODE	LAMP		W	GR	GM	BI
9011*	E27	L max 180mm	75			
9012*	G23		2x9			
9013*	G24d-3		26			
4403*	Emergenza Emergency	2G7	2x9			



Antivandalo | Vandalproof

Code + Colour

CODE	LAMP		W	GR	GM	BI
9067*	E27	L max 180mm	75			
9068*	G23		2x9			
9069*	G24d-3		26			
4462*	Emergenza Emergency	2G7	2x9			

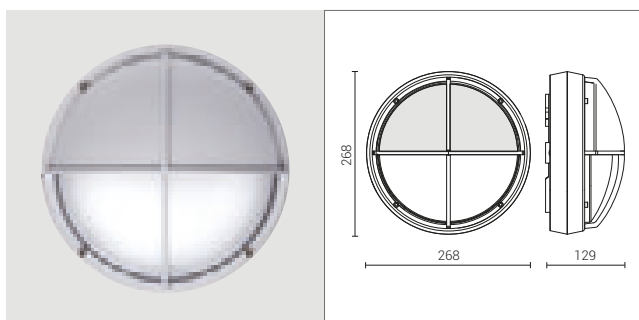
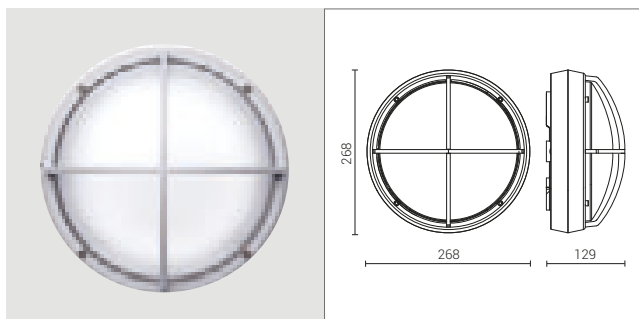

DOCKS



L70 B20
50.000

EN 60598-1
:2015

EN 60598-2
-1:1989
EN 60598-2
-22:2014

DOCKS ALLUMINIO LED | DOCKS ALUMINIUM LED

Emergenza Led: SA 3h.
Illuminazione intelligente (vedi pag. 258).
A richiesta è possibile fornire Illuminazione intelligente + Emergenza.
IP 66 / Classe I / IK 08 - IK 10
CRI 80 / Driver IN
230V / 50 Hz
CE
Tonalità 3000K o 4000K. Aggiungere 3K o 4K al codice dopo il colore.

Emergency Led: maintained lighting 3h.
Intelligent illumination (see page 258).
Intelligent illumination + Emergency version on request.
IP 66 / Class I / IK 08 - IK 10
CRI 80 / Driver IN
230V / 50 Hz
CE
Color temperature available 3000K or 4000K. Add 3K or 4K to the code after the color.

Code + Colour + Tonality

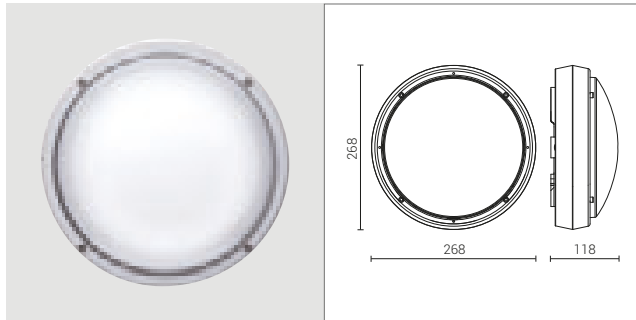

CODE	LAMP	W	Im	Nominali-Real output	GR	GM	BI
9101*	Led	14	1420	600			
4470*	Led + Emergenza 3h Emergency 3h	14	1420/240	600/111			
9102*	Led + Illuminazione intelligente Intelligent illumination	14	1420	600			



Antivandalo | Vandalproof

Code + Colour + Tonality

CODE	LAMP	W	Im	Nominali-Real output	GR	GM	BI
9104*	Led	14	1420	600			
4472*	Led + Emergenza 3h Emergency 3h	14	1420/240	600/111			
9105*	Led + Illuminazione intelligente Intelligent illumination	14	1420	600			

Code + Colour + Tonality

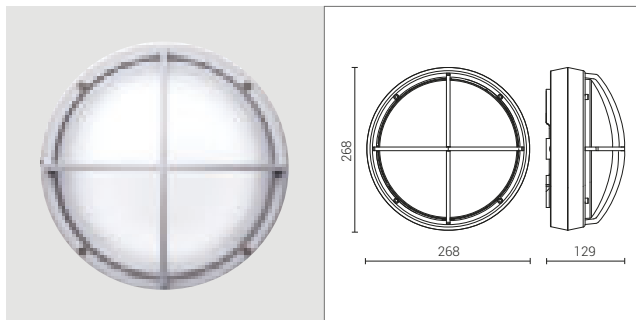

CODE	LAMP	W	Im	Nominali-Real output	GR	GM	BI
9117*	Led	14	1420	600			
4478*	Led + Emergenza 3h Emergency 3h	14	1420/240	600/111			
9119*	Led + Illuminazione intelligente Intelligent illumination	14	1420	600			



Antivandalo | Vandalproof

Code + Colour + Tonality

CODE	LAMP	W	Im	Nominali-Real output	GR	GM	BI
9121*	Led	14	1420	600			
4479*	Led + Emergenza 3h Emergency 3h	14	1420/240	600/111			
9122*	Led + Illuminazione intelligente Intelligent illumination	14	1420	600			

Code + Colour + Tonality

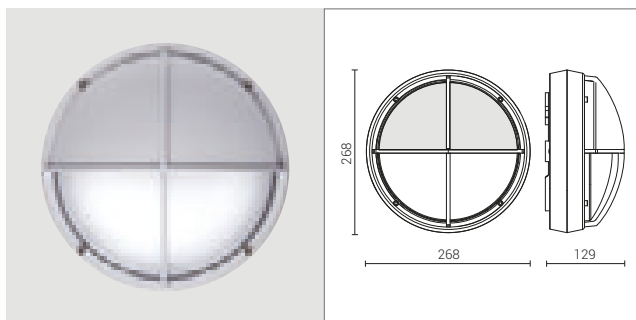

CODE	LAMP	W	Im	Nominali-Real output	GR	GM	BI
9124*	Led	14	1420	298			
4480*	Led + Emergenza 3h Emergency 3h	14	1420/240	298/55			
9125*	Led + Illuminazione intelligente Intelligent illumination	14	1420	298			



Antivandalo | Vandalproof

Code + Colour + Tonality

CODE	LAMP	W	Im	Nominali-Real output	GR	GM	BI
9127*	Led	14	1420	298			
4481*	Led + Emergenza 3h Emergency 3h	14	1420/240	298/55			
9128*	Led + Illuminazione intelligente Intelligent illumination	14	1420	298			

DOCKS

Plafoniere appliques
Wall/ceiling mount



DOCKS INOX AISI 316L | DOCKS STAINLESS STEEL AISI 316L

Emergenza: SA 1h/3h.
IP 66 / Classe I / IK 08 - IK 10
CE

Emergency: maintained lighting 1h/3h.
IP 66 / Class I / IK 08 - IK 10
CE

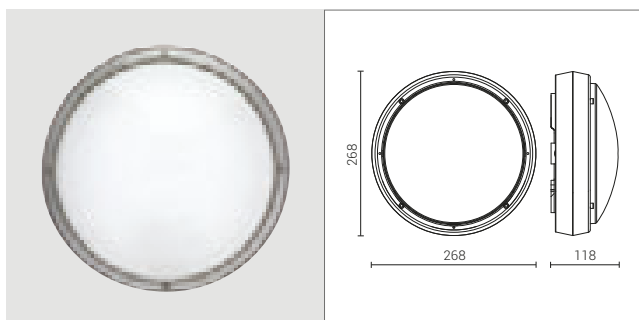

CODE	LAMP		W	IN
9020*	E27	L max 180mm	75	
9021*	G23		2x9	
9022*	G24d-3		26	
4404*	Emergenza Emergency	2G7	2x9	



Antivandalo | Vandalproof

Code + Colour

CODE	LAMP		W	IN
9070*	E27	L max 180mm	75	
9071*	G23		2x9	
9072*	G24d-3		26	
4463*	Emergenza Emergency	2G7	2x9	

Code + Colour

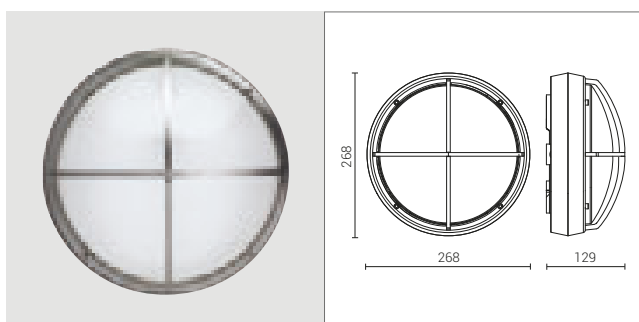

CODE	LAMP		W	IN
9025*	E27	L max 180mm	75	
9026*	G23		2x9	
9027*	G24d-3		26	
4405*	Emergenza Emergency	2G7	2x9	



Antivandalo | Vandalproof

Code + Colour

CODE	LAMP		W	IN
9074*	E27	L max 180mm	75	
9075*	G23		2x9	
9076*	G24d-3		26	
4464*	Emergenza Emergency	2G7	2x9	

Code + Colour

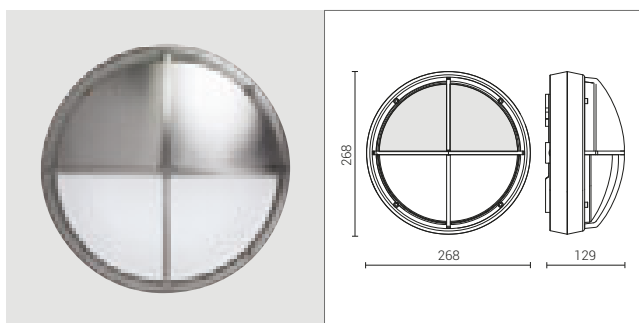

CODE	LAMP		W	IN
9031*	E27	L max 180mm	75	
9032*	G23		2x9	
9033*	G24d-3		26	
4406*	Emergenza Emergency	2G7	2x9	



Antivandalo | Vandalproof

Code + Colour

CODE	LAMP		W	IN
9077*	E27	L max 180mm	75	
9078*	G23		2x9	
9079*	G24d-3		26	
4466*	Emergenza Emergency	2G7	2x9	

Code + Colour

DOCKS



DOCKS INOX AISI 316L LED | DOCKS STAINLESS STEEL AISI 316L LED

Emergenza Led: SA 3h.
 Illuminazione intelligente (vedi pag. 258).
A richiesta è possibile fornire Illuminazione intelligente + Emergenza.
 IP 66 / Classe I / IK 08 - IK 10
 CRI 80 / Driver IN
 230V / 50 Hz
 CE
Tonalità 3000K o 4000K. Aggiungere 3K o 4K al codice dopo il colore.

Emergency Led: maintained lighting 3h.
 Intelligent illumination (see page 258).
Intelligent illumination + Emergency version on request.
 IP 66 / Class I / IK 08 - IK 10
 CRI 80 / Driver IN
 230V / 50 Hz
 CE
Color temperature available 3000K or 4000K. Add 3K or 4K to the code after the color.

Code + Colour + Tonality

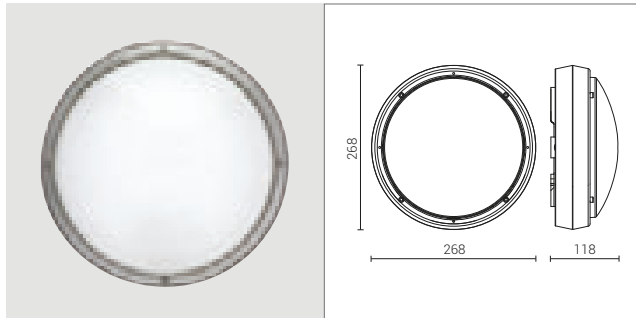

CODE	LAMP	W	Im	Nominali-Real output	IN
9106*	Led	14	1420	600	
4474*	Led + Emergenza 3h Emergency 3h	14	1420/240	600/111	
9107*	Led + Illuminazione intelligente Intelligent illumination	14	1420	600	



Antivandalo | Vandalproof

Code + Colour + Tonality

CODE	LAMP	W	Im	Nominali-Real output	IN
9108*	Led	14	1420	600	
4475*	Led + Emergenza 3h Emergency 3h	14	1420/240	600/111	
9109*	Led + Illuminazione intelligente Intelligent illumination	14	1420	600	

Code + Colour + Tonality

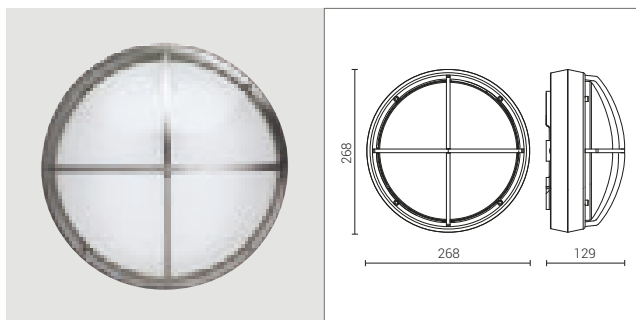

CODE	LAMP	W	Im	Nominali-Real output	IN
9130*	Led	14	1420	600	
4487*	Led + Emergenza 3h Emergency 3h	14	1420/240	600/111	
9131*	Led + Illuminazione intelligente Intelligent illumination	14	1420	600	



Antivandalo | Vandalproof

Code + Colour + Tonality

CODE	LAMP	W	Im	Nominali-Real output	IN
9133*	Led	14	1420	600	
4488*	Led + Emergenza 3h Emergency 3h	14	1420/240	600/111	
9134*	Led + Illuminazione intelligente Intelligent illumination	14	1420	600	

Code + Colour + Tonality

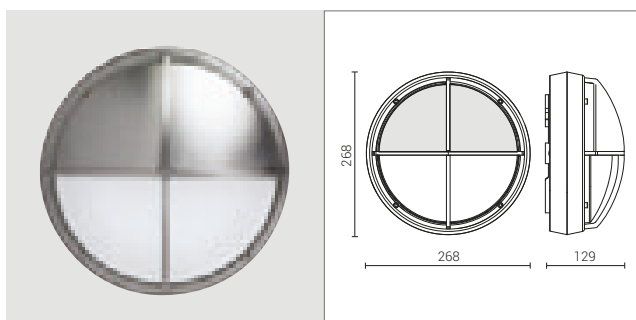

CODE	LAMP	W	Im	Nominali-Real output	IN
9136*	Led	14	1420	298	
4489*	Led + Emergenza 3h Emergency 3h	14	1420/240	298/55	
9137*	Led + Illuminazione intelligente Intelligent illumination	14	1420	298	



Antivandalo | Vandalproof

Code + Colour + Tonality

CODE	LAMP	W	Im	Nominali-Real output	IN
9138*	Led	14	1420	298	
4413*	Led + Emergenza 3h Emergency 3h	14	1420/240	298/55	
9139*	Led + Illuminazione intelligente Intelligent illumination	14	1420	298	

DOCKS

Plafoniere appliques
Wall/ceiling mount



DOCKS OTTONE | DOCKS BRASS

Emergenza: SA 1h/3h.
IP 66 / Classe I / IK 08 - IK 10
CE

Emergency: maintained lighting 1h/3h.
IP 66 / Class I / IK 08 - IK 10
CE

Code + Colour

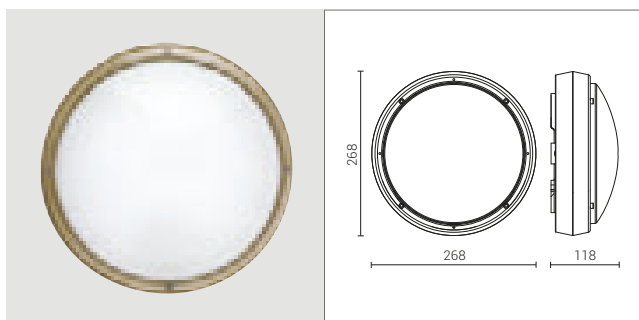

CODE	LAMP		W	OT
9040*	E27	L max 180mm	75	
9041*	G23		2x9	
9042*	G24d-3		26	
4407*	Emergenza Emergency	2G7	2x9	



Antivandalo | Vandalproof

Code + Colour

CODE	LAMP		W	OT
9080*	E27	L max 180mm	75	
9081*	G23		2x9	
9082*	G24d-3		26	
4459*	Emergenza Emergency	2G7	2x9	

Code + Colour

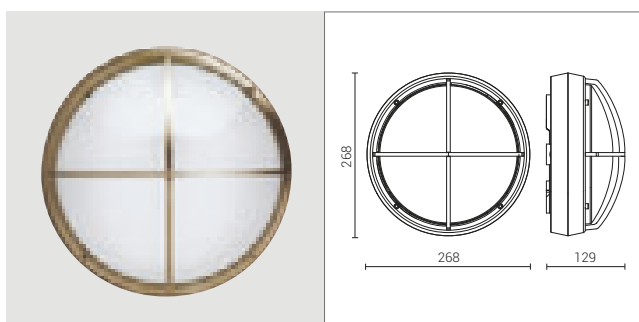

CODE	LAMP		W	OT
9045*	E27	L max 180mm	75	
9046*	G23		2x9	
9047*	G24d-3		26	
4408*	Emergenza Emergency	2G7	2x9	



Antivandalo | Vandalproof

Code + Colour

CODE	LAMP		W	OT
9084*	E27	L max 180mm	75	
9085*	G23		2x9	
9086*	G24d-3		26	
4468*	Emergenza Emergency	2G7	2x9	

Code + Colour

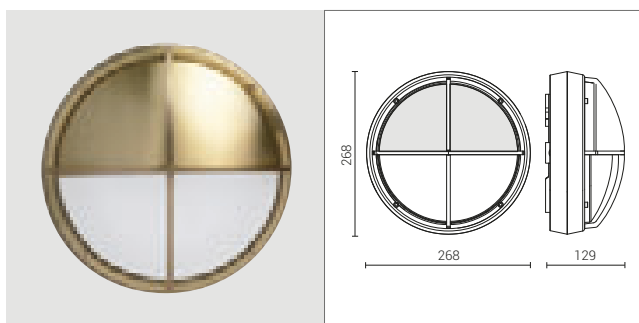

CODE	LAMP		W	OT
9051*	E27	L max 180mm	75	
9052*	G23		2x9	
9053*	G24d-3		26	
4409*	Emergenza Emergency	2G7	2x9	



Antivandalo | Vandalproof

Code + Colour

CODE	LAMP		W	OT
9087*	E27	L max 180mm	75	
9088*	G23		2x9	
9089*	G24d-3		26	
4469*	Emergenza Emergency	2G7	2x9	

DOCKS



L70 B20
50.000

EN 60598-1
:2015

EN 60598-2
-1:1989
EN 60598-2
-22:2014

DOCKS OTTONE LED | DOCKS BRASS LED

Emergenza Led: SA 3h.
Illuminazione intelligente (vedi pag. 258).
A richiesta è possibile fornire Illuminazione intelligente + Emergenza.
IP 66 / Classe I / IK 08 - IK 10
CRI 80 / Driver IN
230V / 50 Hz
CE
Tonalità 3000K o 4000K. Aggiungere 3K o 4K al codice dopo il colore.

Emergency Led: maintained lighting 3h.
Intelligent illumination (see page 258).
Intelligent illumination + Emergency version on request.
IP 66 / Class I / IK 08 - IK 10
CRI 80 / Driver IN
230V / 50 Hz
CE
Color temperature available 3000K or 4000K. Add 3K or 4K to the code after the color.

Code + Colour + Tonality

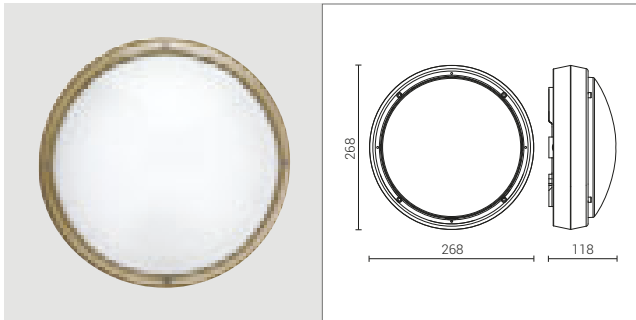

CODE	LAMP	W	Im	Nominali-Real output	OT
9110*	Led	14	1420	600	
4476*	Led + Emergenza 3h Emergency 3h	14	1420/240	600/111	
9111*	Led + Illuminazione intelligente Intelligent illumination	14	1420	600	



Antivandalo | Vandalproof

Code + Colour + Tonality

CODE	LAMP	W	Im	Nominali-Real output	OT
9114*	Led	14	1420	600	
4477*	Led + Emergenza 3h Emergency 3h	14	1420/240	600/111	
9115*	Led + Illuminazione intelligente Intelligent illumination	14	1420	600	

Code + Colour + Tonality

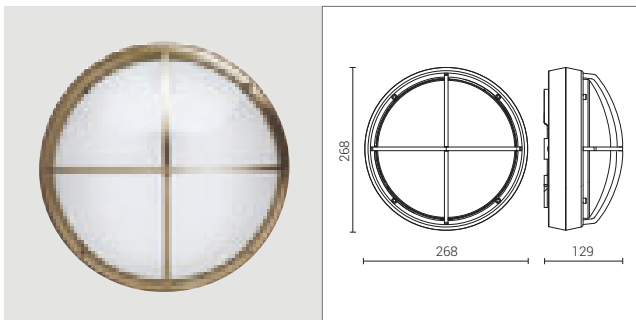

CODE	LAMP	W	Im	Nominali-Real output	OT
9140*	Led	14	1420	600	
4414*	Led + Emergenza 3h Emergency 3h	14	1420/240	600/111	
9141*	Led + Illuminazione intelligente Intelligent illumination	14	1420	600	



Antivandalo | Vandalproof

Code + Colour + Tonality

CODE	LAMP	W	Im	Nominali-Real output	OT
9143*	Led	14	1420	600	
4415*	Led + Emergenza 3h Emergency 3h	14	1420/240	600/111	
9144*	Led + Illuminazione intelligente Intelligent illumination	14	1420	600	

Code + Colour + Tonality

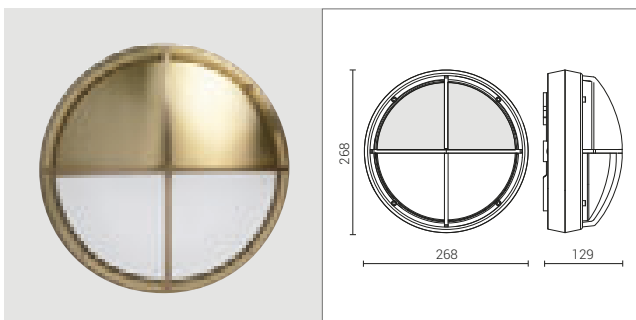

CODE	LAMP	W	Im	Nominali-Real output	OT
9146*	Led	14	1420	298	
4416*	Led + Emergenza 3h Emergency 3h	14	1420/240	298/55	
9147*	Led + Illuminazione intelligente Intelligent illumination	14	1420	298	



Antivandalo | Vandalproof

Code + Colour + Tonality

CODE	LAMP	W	Im	Nominali-Real output	OT
9148*	Led	14	1420	298	
4417*	Led + Emergenza 3h Emergency 3h	14	1420/240	298/55	
9149*	Led + Illuminazione intelligente Intelligent illumination	14	1420	298	



KASKO

Brevetto depositato
Registered patent

PLAFONIERE APPLIQUES WALL/CEILING MOUNT



Kasko Tonda
Round Kasko

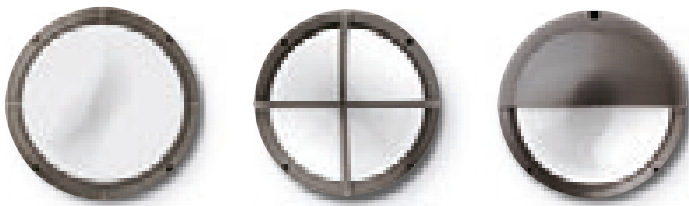

Kasko Tonda Grande
Large Round Kasko

LED



Kasko Ovale
Oval Kasko

Forme rigorose, materiali hi-tec, finiture che fanno tendenza consentono a KASKO un inserimento perfetto nell'architettura contemporanea. Una lampada indistruttibile, nata per sfidare polvere e getti d'acqua, garantendo la tenuta stagna anche nelle condizioni di installazione più difficili. Le coppe antivandalo ne consentono l'utilizzo anche in ambienti pubblici. KASKO: armonia delle forme e solidità della struttura incontrano l'ambiente, coniugando tradizione estetica e raffinata tecnologia costruttiva.

Classical shape, hi-tech materials and modern construction: that's why KASKO is a good match for contemporary architecture. A fitting manufactured to resist the ingress of dust and water due to its airtight seal even in the toughest of conditions. A vandalproof diffuser makes KASKO suitable for open access areas. KASKO on the Venetian laguna. The fitting enhances its surroundings by merging new and old aesthetic traditions.



KASKO

Plafoniere appliques
Wall/ceiling mount

CARATTERISTICHE GENERALI

- Plafoniera per esterno in alluminio.
- **Struttura:** diffusore in vetro opale stampato, policarbonato opale IK 10 per antivandalo. Guarnizioni di tenuta in silicone. Corpo in alluminio pressofuso a basso tenore di rame. Base in alluminio pressofuso. Piattello interno reggicablaggio in Al 99,8. Palo in alluminio estruso e retropiastra in alluminio pressofuso.
- Alimentazione passante possibile.
- Installabile a parete, a soffitto o su palo.
- **Sorgenti luminose** ad alto rendimento e basso consumo o Led di nuova generazione con vita garantita 50.000 h con successivo scadimento max del 20%. Driver incorporato.
- **Emergenza:** per basso consumo SA 1h/3h; per Led SA 3h.
- **Illuminazione intelligente:** per l'applicazione a Led sono disponibili le varianti con "illuminazione intelligente" (0-10-20-30% in stato di quiete con accensione automatica al 100% al passaggio) o per "emergenza SA" sempre accesa.
- **Finitura:** su alluminio, decappaggio + fosfocromatazione + fondo epossidico + verniciatura con polveri epossidiche stabilizzate anti UV.
- Costruito in conformità alle norme europee EN 60598-1:2015 **CE**

GENERAL FEATURES

- *Aluminium outdoor ceiling light.*
- **Structure:** moulded opal glass, IK 10 vandalproof polycarbonate diffuser. Silicone sealing gaskets. Low copper content die-cast aluminium body. Aluminium die-cast base. Internal wire holder plate in Al 99.8. Extruded aluminium post and die-cast aluminium back-cover.
- *Through power possible.*
- *Can be installed on walls, ceilings, or posts.*
- **High performance, low consumption light sources** or new generation LEDs with minimum life 50,000 h with subsequent deterioration max 20%. Driver inside.
- **Emergency:** for energy savings SA 1h/3h; for LED SA 3h.
- **Intelligent illumination:** variations for "intelligent illumination" (0-10-20-30% night light with automatic ignition at 100% when sensor detects people in the area) available for LED application or for "SA emergency" (light always on).
- **Finish:** on aluminium, pickling + phosphochrome + epoxy basic coating + UV resistant stabilised epoxy powder coating.
- *Manufactured in compliance with European standards EN 60598-1:2015 **CE***

STRUTTURA IN ALLUMINIO PRESSOFUSO

- 1 - Griglia, palpebra e anello sono in pressofusione di alluminio. Viti a brugola in acciaio inox.
- 2 - Coppa in vetro opale o in policarbonato opale.
- 3 - Guarnizione di tenuta al silicone antinvecchiamento.
- 4 - Riflettore cablato con unità Led.
- 5 - Dissipatore di calore.
- 6 - Base in alluminio pressofuso.



DIE-CAST ALUMINIUM STRUCTURE

- 1 - Die-cast aluminium guard, cover and ring. Stainless steel allen key screws.
- 2 - Opal glass or opal polycarbonate diffuser.
- 3 - Silicone gasket.
- 4 - Led unit and its plate.
- 5 - Heat sink.
- 6 - Die-cast aluminium housing.

IRRAGGIAMENTO VERSO IL BASSO

La forma semisferica è stata progettata per allontanare dalla base la lampada portandola nella posizione migliore per diffondere più efficacemente la luce. Il portalampada è posizionato in alto, grazie al precablaggio con cavi resistenti al calore. La luce viene così irradiata verso il basso.

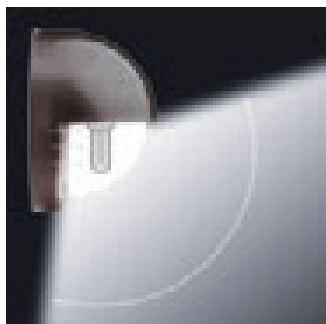

DOWNWARD LIGHT DISTRIBUTION

KASKO has been designed with its semispherical shape to provide maximum illumination. The lampholder is installed on the top and the light is oriented downwards.

KASKO LED LUCE STANDARD

- 1 - Unità Led 230V/1420 Lumen
- 2 - Lente diffondente
- 3 - Diffusore

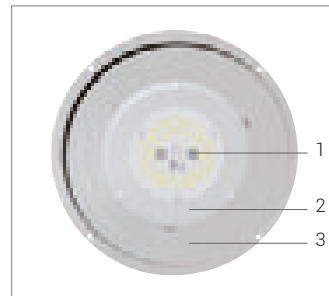

KASKO LED NORMAL LIGHT

- 1 - Led unit 230V/1420 Lumen
- 2 - Fresnel lens
- 3 - Light enlarging plate

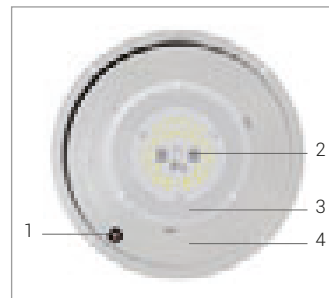

KASKO LED LUCE STANDARD + EMERGENZA

- 1 - Unità Led emergenza 240 Lumen
- 2 - Unità Led 230V/1420 Lumen
- 3 - Lente diffondente
- 4 - Diffusore

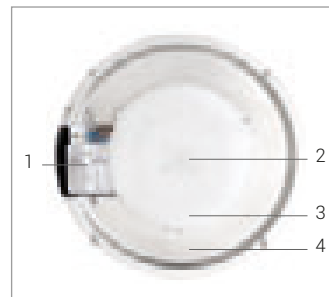

KASKO LED MAINTAINED LIGHTING (NORMAL LIGHT + EMERGENCY)

- 1 - Led unit for emergency 240 Lumen
- 2 - Led unit 230V/1420 Lumen
- 3 - Fresnel lens
- 4 - Light enlarging plate

KASKO LED ILLUMINAZIONE INTELLIGENTE

- 1 - Rilevatore di presenza a microonde + dimmer. Regolazioni: area rilevazione, temporizzazione, luce crepuscolare
- 2 - Unità Led 230V/1420 Lumen
- 3 - Lente diffondente
- 4 - Diffusore

KASKO LED INTELLIGENT ILLUMINATION

- 1 - Pir Sensor Detector + dimmer. Regulations: area, timer, daylight
- 2 - Led unit 230V/1420 Lumen
- 3 - Fresnel lens
- 4 - Light enlarging plate

KASKO

Plafoniere appliques
Wall/ceiling mount



KASKO TONDA CON ANELLO | ROUND KASKO

Code + Colour

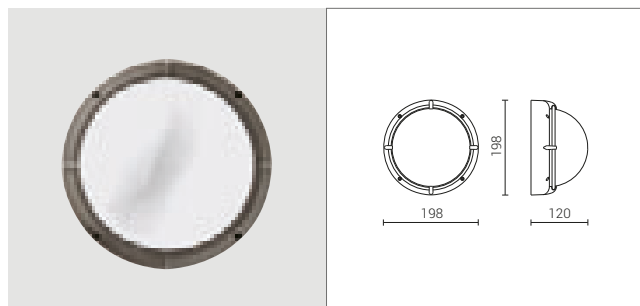

CODE LAMP W BI GR SI

8410* E 27 Dulux EI L max 117mm 100
11

8411* G24d-1 10



Antivandalo | Vandalproof

Code + Colour

CODE LAMP W BI GR SI

8490* E 27 Dulux EI L max 117mm 75
11

8491* G24d-1 10

IP 65 / Classe I
IK 08 - IK 10
230V / 50 Hz
CE

IP 65 / Class I
IK 08 - IK 10
230V / 50 Hz
CE

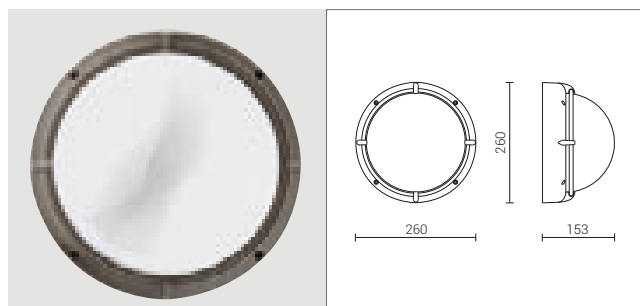

Code + Colour

CODE LAMP W BI GR SI

8420* E 27 Dulux EI L max 145mm 150
20

8428* G23 2x9

8426* G24d-3 26

8422* G24d-3 2x26

4484* Emergenza Emergency 2G7 2x9



Antivandalo | Vandalproof

Code + Colour

CODE LAMP W BI GR SI

8495* E 27 Dulux EI L max 145mm 100
20

8496* G23 2x9

8497* G24d-3 26

4490* Emergenza Emergency 2G7 2x9

Emergenza: SA 1h/3h.
IP 65 / Classe I
IK 08 - IK 10
230V / 50 Hz
CE

Emergency: maintained lighting 1h/3h.
IP 65 / Class I
IK 08 - IK 10
230V / 50 Hz
CE



KASKO TONDA LED CON ANELLO | ROUND KASKO LED

Code + Colour + Tonality

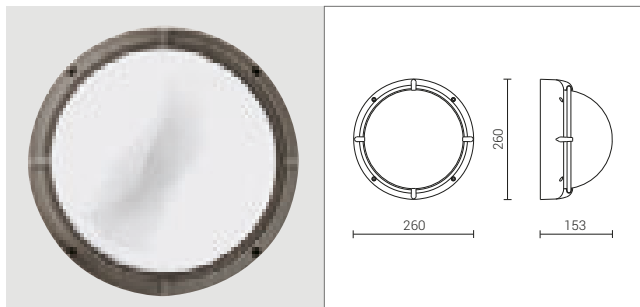

CODE	LAMP	W	lm	Nominali-Real output	BI	GR	SI
------	------	---	----	----------------------	----	----	----

9150*	Led	14	1420	645			
9151*	Led + Emergenza 3h Emergency 3h	14	1420/240	645/119			
9152*	Led + Illuminazione intelligente Intelligent illumination	14	1420	645			



Antivandalo | Vandalproof

Code + Colour + Tonality

CODE	LAMP	W	lm	Nominali-Real output	BI	GR	SI
------	------	---	----	----------------------	----	----	----

9154*	Led	14	1420	645			
9155*	Led + Emergenza 3h Emergency 3h	14	1420/240	645/119			
9156*	Led + Illuminazione intelligente Intelligent illumination	14	1420	645			

Emergenza: SA 3h.
Illuminazione intelligente (vedi pag. 269).
A richiesta è possibile fornire Illuminazione intelligente + Emergenza.
IP 65 / Classe I
IK 08 - IK 10
CRI 80 / Driver IN
230V / 50 Hz
€€
Tonalità 3000K o 4000K.
Aggiungere 3K o 4K al codice dopo il colore.

Emergency: maintained lighting 3h.
Intelligent illumination (see page 269).
Intelligent illumination + Emergency version on request.
IP 65 / Class I
IK 08 - IK 10
CRI 80 / Driver IN
230V / 50 Hz
€€
Color temperature available 3000K or 4000K.
Add 3K or 4K to the code after the color.

KASKO

Plafoniere appliques
Wall/ceiling mount



KASKO TONDA CON GRIGLIA | ROUND KASKO WITH GUARD

Code + Colour

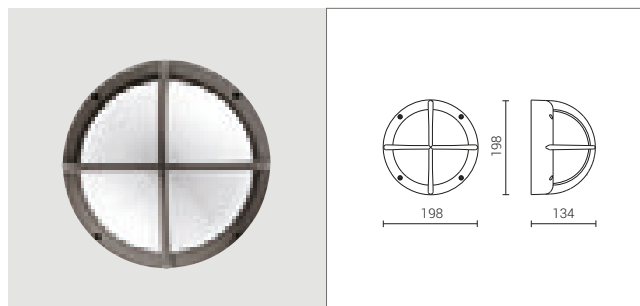

CODE LAMP W BI GR SI

8310* E 27 Dulux EI L max 117mm 100
11

8311* G24d-1 10



Antivandalo | Vandalproof

Code + Colour

CODE LAMP W BI GR SI

8390* E 27 Dulux EI L max 117mm 75
11

8391* G24d-1 10

IP 65 / Classe I
IK 08 - IK 10
230V / 50 Hz
CE

IP 65 / Class I
IK 08 - IK 10
230V / 50 Hz
CE

Code + Colour

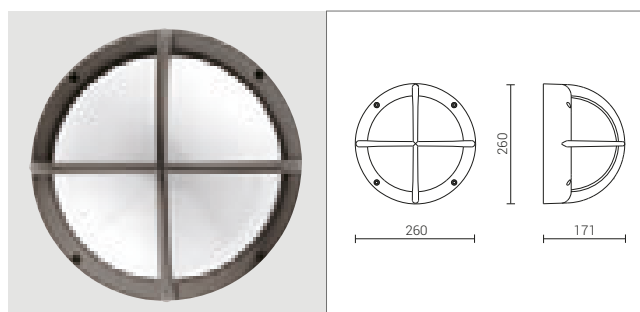

CODE LAMP W BI GR SI

8320* E 27 Dulux EI L max 145mm 150
20

8328* G23 2x9

8326* G24d-3 26

8322* G24d-3 2x26

4483* Emergenza Emergency 2G7 2x9



Antivandalo | Vandalproof

Code + Colour

CODE LAMP W BI GR SI

8395* E 27 Dulux EI L max 145mm 100
20

8396* G23 2x9

8397* G24d-3 26

4491* Emergenza Emergency 2G7 2x9

Emergenza: SA 1h/3h.
IP 65 / Classe I
IK 08 - IK 10
230V / 50 Hz
CE

Emergency: maintained lighting 1h/3h.
IP 65 / Class I
IK 08 - IK 10
230V / 50 Hz
CE



KASKO TONDA LED CON GRIGLIA | ROUND KASKO LED WITH GUARD

Code + Colour + Tonality

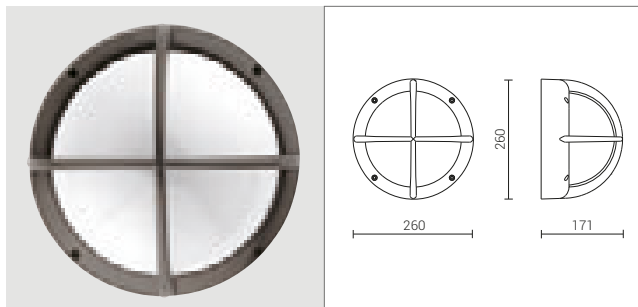

CODE	LAMP	W	lm	Nominali-Real output	BI	GR	SI
NEW NEW 9160*	Led	14	1420	645			
NEW NEW 9161*	Led + Emergenza 3h Emergency 3h	14	1420/240	645/119			
NEW NEW 9162*	Led + Illuminazione intelligente Intelligent illumination	14	1420	645			



Antivandalo | Vandalproof

Code + Colour + Tonality

CODE	LAMP	W	lm	Nominali-Real output	BI	GR	SI
NEW NEW 9164*	Led	14	1420	645			
NEW NEW 9165*	Led + Emergenza 3h Emergency 3h	14	1420/240	645/119			
NEW NEW 9166*	Led + Illuminazione intelligente Intelligent illumination	14	1420	645			

Emergenza: SA 3h.
Illuminazione intelligente (vedi pag. 269).
A richiesta è possibile fornire Illuminazione intelligente + Emergenza.
IP 65 / Classe I
IK 08 - IK 10
CRI 80 / Driver IN
230V / 50 Hz
CE
Tonalità 3000K o 4000K.
Aggiungere 3K o 4K al codice dopo il colore.

Emergency: maintained lighting 3h.
Intelligent illumination (see page 269).
Intelligent illumination + Emergency version on request.
IP 65 / Class I
IK 08 - IK 10
CRI 80 / Driver IN
230V / 50 Hz
CE
Color temperature available 3000K or 4000K.
Add 3K or 4K to the code after the color.

KASKO

Plafoniere appliques
Wall/ceiling mount



KASKO TONDA CON PALPEBRA | ROUND KASKO WITH COVER

Code + Colour

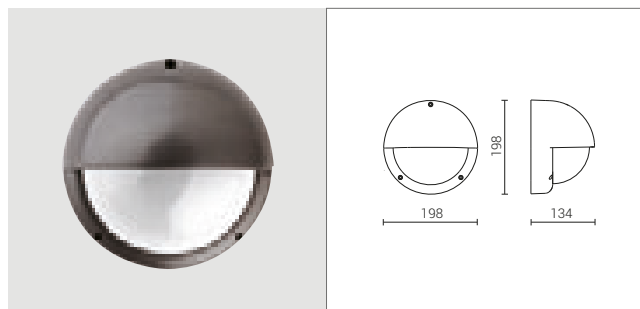

CODE	LAMP	W	BI	GR	SI
------	------	---	----	----	----

8610*	E 27 Dulux EI	L max 117mm	75	11	
8611*	G24d-1		10		



Antivandalo | Vandalproof

Code + Colour

CODE	LAMP	W	BI	GR	SI
------	------	---	----	----	----

8690*	E 27 Dulux EI	L max 117mm	60	11	
8691*	G24d-1		10		

IP 65 / Classe I
IK 08 - IK 10
230V / 50 Hz
CE

IP 65 / Class I
IK 08 - IK 10
230V / 50 Hz
CE

Code + Colour

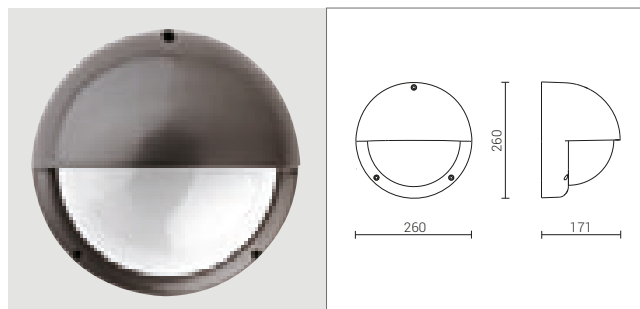

CODE	LAMP	W	BI	GR	SI
------	------	---	----	----	----

8620*	E 27 Dulux EI	L max 145mm	100	20	
8628*	G23		2x9		
8626*	G24d-3		26		
4486*	Emergenza Emergency	2G7	2x9		



Antivandalo | Vandalproof

Code + Colour

CODE	LAMP	W	BI	GR	SI
------	------	---	----	----	----

8695*	E 27 Dulux EI	L max 145mm	75	20	
8696*	G23		2x9		
8697*	G24d-3		26		
4492*	Emergenza Emergency	2G7	2x9		

Emergenza: SA 1h/3h.
IP 65 / Classe I
IK 08 - IK 10
230V / 50 Hz
CE

Emergency: maintained lighting 1h/3h.
IP 65 / Class I
IK 08 - IK 10
230V / 50 Hz
CE

KASKO

Plafoniere appliques
Wall/ceiling mount



KASKO TONDA LED CON PALPEBRA | ROUND KASKO LED WITH COVER

Code + Colour + Tonality

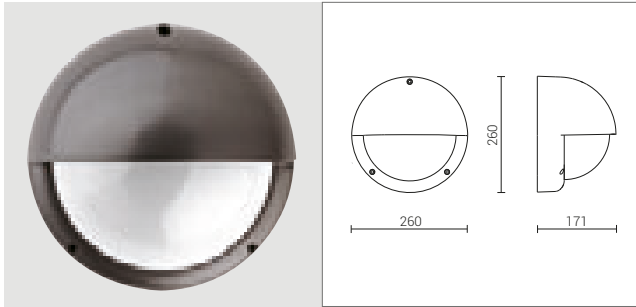

CODE	LAMP	W	lm	Nominali-Real output	BI	GR	SI
NEW 9170*	Led	14	1420	645			
NEW 9171*	Led + Emergenza 3h Emergency 3h	14	1420/240	645/119			
NEW 9172*	Led + Illuminazione intelligente Intelligent illumination	14	1420	645			



Antivandalo | Vandalproof

Code + Colour + Tonality

CODE	LAMP	W	lm	Nominali-Real output	BI	GR	SI
NEW 9174*	Led	14	1420	645			
NEW 9175*	Led + Emergenza 3h Emergency 3h	14	1420/240	645/119			
NEW 9176*	Led + Illuminazione intelligente Intelligent illumination	14	1420	645			

Emergenza: SA 3h.
Illuminazione intelligente (vedi pag. 269).
A richiesta è possibile fornire Illuminazione intelligente + Emergenza.
IP 65 / Classe I
IK 08 - IK 10
CRI 80 / Driver IN
230V / 50 Hz
CE
Tonalità 3000K o 4000K.
Aggiungere 3K o 4K al codice dopo il colore.

Emergency: maintained lighting 3h.
Intelligent illumination (see page 269).
Intelligent illumination + Emergency version on request.
IP 65 / Class I
IK 08 - IK 10
CRI 80 / Driver IN
230V / 50 Hz
CE
Color temperature available 3000K or 4000K.
Add 3K or 4K to the code after the color.



EN 60598-1
:2015

EN 60598-2
-1:1989
EN 60598-2
-22:2014

KASKO OVALE CON ANELLO | OVAL KASKO

Code + Colour

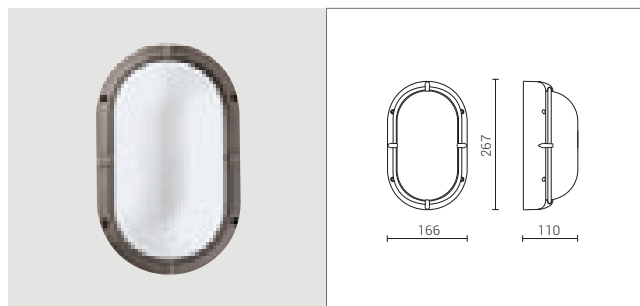

CODE	LAMP	W	BI	GR	SI
8210*	E 27 Dulux EI L max 173mm	100 20			
8218*	G23	2x9			
8216*	G24d-3	26			



Antivandalo | Vandalproof

Code + Colour

CODE	LAMP	W	BI	GR	SI
8290*	E 27 Dulux EI L max 173mm	60 20			
8298*	G23	2x9			
8296*	G24d-3	26			

IP 65 / Classe I
IK 08 - IK 10
230V / 50 Hz
CE

IP 65 / Class I
IK 08 - IK 10
230V / 50 Hz
CE

KASKO OVALE CON GRIGLIA | OVAL KASKO WITH GUARD

Code + Colour

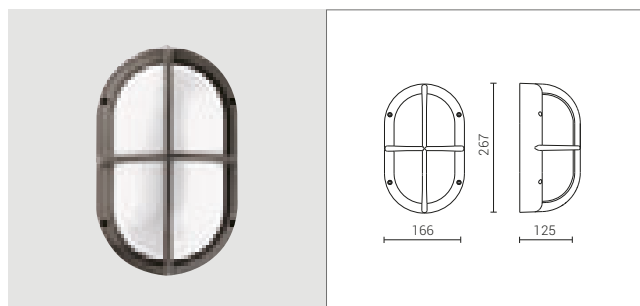

CODE	LAMP	W	BI	GR	SI
8110*	E 27 Dulux EI L max 173mm	100 20			
8118*	G23	2x9			
8116*	G24d-3	26			



Antivandalo | Vandalproof

Code + Colour

CODE	LAMP	W	BI	GR	SI
8190*	E 27 Dulux EI L max 173mm	60 20			
8198*	G23	2x9			
8196*	G24d-3	26			

IP 65 / Classe I
IK 08 - IK 10
230V / 50 Hz
CE

IP 65 / Class I
IK 08 - IK 10
230V / 50 Hz
CE

KASKO

Plafoniere appliques
Wall/ceiling mount



KASKO OVALE CON PALPEBRA | OVAL KASKO WITH COVER

Code + Colour

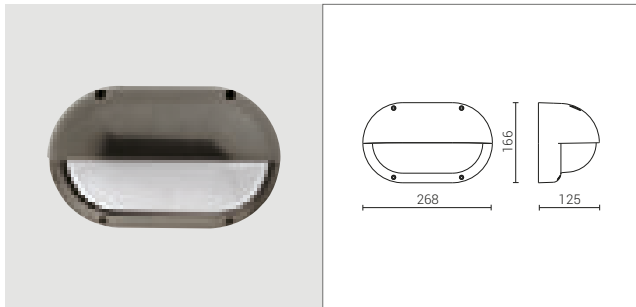

CODE	LAMP	W	BI	GR	SI
8810*	E 27 Dulux EI L max 173mm	100 20			
8818*	G23	2x9			
8816*	G24d-3	26			



Antivandalo | Vandalproof

Code + Colour

CODE	LAMP	W	BI	GR	SI
8890*	E 27 Dulux EI L max 173mm	60 20			
8898*	G23	2x9			
8896*	G24d-3	26			

IP 65 / Classe I
IK 08 - IK 10
230V / 50 Hz
CE

IP 65 / Class I
IK 08 - IK 10
230V / 50 Hz
CE

KASKO PALI A "U" DIRITTI | KASKO U-POSTS

Code + Colour

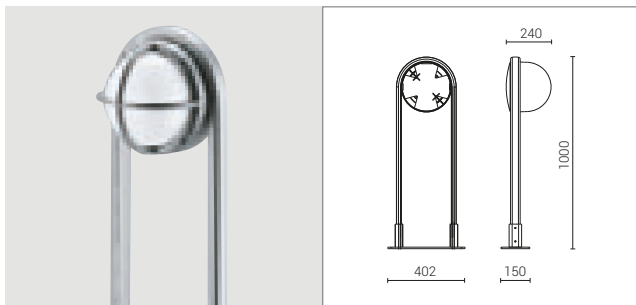

CODE	DESCRIZIONE / DESCRIPTION	GR	SI
3686*	Palo a "U" diritto per Kasko Tonda Grande <i>U-post for large round Kasko</i>		

Una seconda lampada contrapposta può essere montata eliminando la retropietra. Pali forniti completi di basetta. Praticando un secondo foro passaggio cavi è possibile l'alimentazione passante. Solo palo - apparecchi Kasko forniti separatamente.

A second fitting can be installed by removing the back-cover. U-posts supplied with base. With a second hole the fitting is suitable for entry-exit cable installation. U-post only, Kasko fittings are supplied separately.

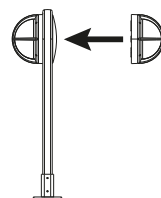
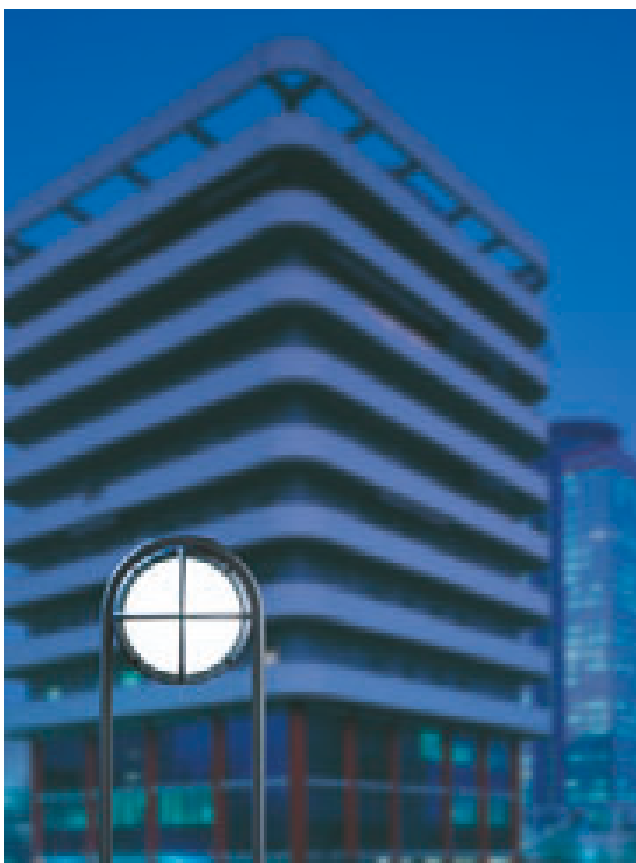

Curve fotometriche: vedi capitolo specifico.
Classe Energetica: vedi capitolo specifico.
Photometric data: go to relevant chapter. Energy class: go to code index.



FEELING

PLAFONIERE APPLIQUES WALL/CEILING MOUNT

FEELING è un apparecchio a soffitto di grande effetto per ambienti sofisticati ed eleganti. Contiene sorgenti di luce innovative e di grande resa. Il particolare sistema di assemblaggio facilita l'installazione ed elimina le viti a vista. La versione con retroilluminazione colorata emana una doppia luce creando un effetto suggestivo e intrigante.

La serie è completata dalla versione con Led di potenza in grado di offrire diverse utili funzioni: rilevatore di presenza, emergenza sempre accesa, illuminazione intelligente con rilevatore di presenza che, oltre al normale funzionamento con intensità regolabile al 0-10-20-30%, si accende al 100% quando una persona entra nell'area del rilevatore.

FEELING is a ceiling lamp of great effect developed for sophisticated and elegant ambiances, equipped with innovative light sources at high-performance and interesting energy-saving functions. The assembly system has been developed for easy installation. The mounting screws are not visible. Two versions: a standard one and another one emanating a double light. A strong and wide beam to the floor and a blue, green or opalescent light upwards creating an evocative and special atmosphere on the ceiling. New generation power led and special function with sensor and intelligent illumination: normally the light is reduced to 0-10-20-30% and comes on to 100% when somebody is detected in the area.



FEELING

Plafoniere appliques
Wall/ceiling mount



Feeling
LED





FEELING

Plafoniere appliques
Wall/ceiling mount

CARATTERISTICHE GENERALI

- Plafoniera per esterno con versione a doppia illuminazione.
- **Struttura:** corpo in policarbonato opaco rinforzato con intelaiatura di alluminio pressofuso. Cerchio di chiusura in alluminio spazzolato incernierato al corpo, con chiusura a scatto per facilitare il montaggio. Fissaggio assicurato da viti a scomparsa. Diffusore frontale in policarbonato opale anti UV. Guarnizioni di tenuta in silicone.
- **Doppia illuminazione:** corpo posteriore in policarbonato traslucido, disponibile in 3 colori.
- **Sorgenti luminose** ad alto rendimento e basso consumo o unità Led 25W / 230V / CRI 80 (altre tonalità a richiesta) di nuova generazione con vita garantita 50.000 h con successivo scadimento max del 20%. Driver incorporato.
- **Emergenza:** per basso consumo SA 1h; per Led SA 3h.
- **Illuminazione intelligente:** per l'applicazione a Led sono disponibili le varianti per "emergenza SA" sempre accesa o con "illuminazione intelligente" (0-10-20-30% in stato di quiete con accensione automatica al 100% al passaggio) con rilevatore di presenza a microonde e regolazione di area rilevazione, temporizzazione, luce crepuscolare.
- Costruito in conformità alle norme europee EN 60598-1:2015 CE

GENERAL FEATURES

- *Outdoor ceiling light with double illumination version.*
- **Structure:** body in reinforced matt polycarbonate with die-cast aluminium frame. Ring in brushed aluminium hinged to the body, with snap closure for easy installation. Secured with concealed screws. Front opal UV resistant polycarbonate diffuser. Silicone sealing gaskets.
- **Double illumination:** rear body in translucent polycarbonate, available in 3 colours.
- **High performance, low consumption light sources** or new generation 25W / 230V / CRI 80 LEDs (other tonalities upon request) with minimum life 50,000 h with subsequent deterioration max 20%. Driver inside.
- **Emergency:** for energy savings SA 1h; for LED SA 3h.
- **Intelligent illumination:** for LED application, variations are available for "emergency SA" (light always on) or for "intelligent illumination" (0-10-20-30% night light with automatic ignition at 100% when sensor detects people in the area) with microwave sensor and area, timer, and daylight regulations.
- *Manufactured in compliance with European standards EN 60598-1:2015 CE*

FEELING LED

LUCE STANDARD

Unità Led 230V, 25W, 2500 Lumen, CRI 80. Accensione immediata. Durata 50.000 h con decremento max del 20%.

LUCE STANDARD+EMERGENZA

Funzionamento in S.A. (sempre accesa), innesto automatico dell'emergenza.

1 - Unità Led 230V/2500 Lumen.



STANDARD LIGHT

Led unit 2500 lumen / 230V driver inside / 25W / CRI 80. Instant start. Life 50.000 hours with max decreasing of 20%.

STANDARD LIGHT + EMERGENCY

Maintained light function. The light comes on automatically after black-out.

1 - Led unit 230V/2500 Lumen.

ILLUMINAZIONE INTELLIGENTE

Regolazione a 0/10/20/30% della luce notturna tramite dimmer interno. Accensione a luce piena tramite rilevatore di presenza. Tre regolazioni: area rilevatore, temporizzazione, luce crepuscolare.

1 - Rilevatore di presenza + dimmer per illuminazione intelligente.
2 - Unità Led 230V/2500 Lumen.

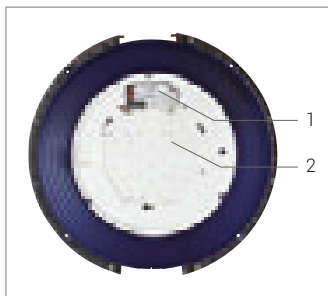

INTELLIGENT ILLUMINATION

Adjustable night light to 0/10/20/30% by a dimmer inside and light on to 100% when the Pir Sensor detects people in the area. Three regulations: area, timer, daylight.

1 - Pir Sensor Detector + dimmer for intelligent illumination.
2 - Led unit 230V/2500 Lumen.

STRUTTURA ROBUSTA

- 1 - Base in policarbonato.
- 2 - Fissaggio a scatto.
- 3 - Bordo di chiusura in alluminio.
- 4 - Diffusore in policarbonato opale.

STRONG STRUCTURE

- 1 - Polycarbonate housing.
- 2 - Snapping block.
- 3 - Fixing border in die-cast aluminium.
- 4 - Opal polycarbonate diffuser.

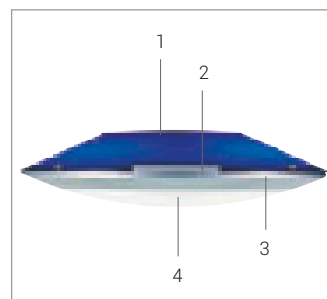

MONTAGGIO FACILITATO

Può essere eseguito da una sola persona grazie al particolare sistema di snodo del diffusore con chiusura a scatto.

EASY INSTALLATION

Can be performed by a single person, thanks to the special adjustable diffuser system with snap closure.



BLOCCAGGIO

Bloccaggio delle viti posteriori con apposito accessorio fornito.

LOCKING

Block the back screws with the orange screwdriver supplied.

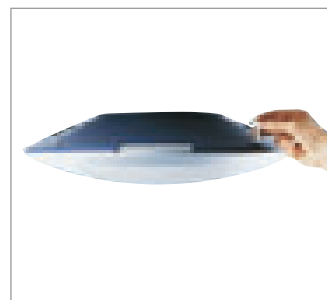



FEELING

Plafoniere appliques
Wall/ceiling mount

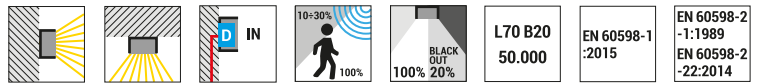

FEELING SENZA RETROILLUMINAZIONE | FEELING WITHOUT BACK-LIGHT

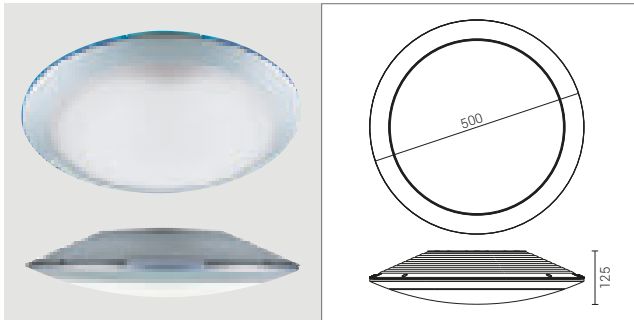

Antivandalo | **Vandalproof**

Code + Colour

CODE	LAMP	W	GR	GM
4881*	E27 Dulux L max 173mm	3x60 3x23		
4883*	2G11	2x18		
4429*	Emergenza 1h Emergency 1h	2G11		



Antivandalo | **Vandalproof**

Code + Colour + Tonality

CODE	LAMP	W	Im Nominali - Real output	GR	GM
4821*	Led	25	2500 1158		
4439*	Led + Emergenza 3h Emergency 3h	25	2500/400 1158/154		
4825*	Led + Illuminazione intelligente Intelligent illumination	25	2500 1158		
4440*	Led + Illuminazione intelligente+ Emergenza Intelligent illumination+ Emergency	25	2500/400 1158/154		

Emergenza: SA 1h; per Led: SA 3h.
Illuminazione intelligente (vedi pag. 283).
IP 65 / Classe II : cod. 4881/
IK 10
CRI 80 / Driver IN / 500 mA
230V / 50 Hz **CE**
Tonaltà **3000K o 4000K. Aggiungere 3K
o 4K al codice dopo il colore.**

Emergency: maintained lighting 1h; Led:
maintained lighting 3h.
Intelligent illumination (see page 283).
IP 65 / Class II : code 4881/
IK 10
CRI 80 / Driver IN / 500 mA
230V / 50 Hz **CE**
Color temperature available **3000K or
4000K. Add 3K or 4K to the code after
the color.**

FEELING CON RETROILLUMINAZIONE | FEELING WITH BACK-LIGHT

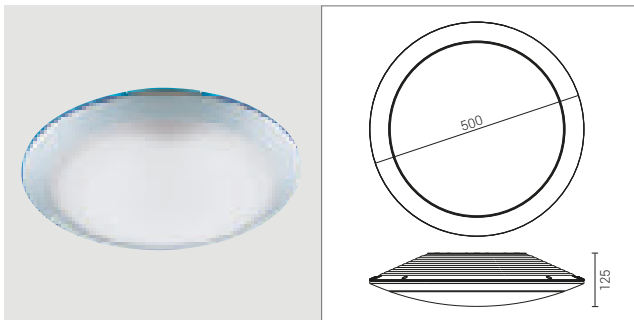

Antivandalo | **Vandalproof**

Code + Colour

CODE	LAMP	W	GR	GM	+
4890*	E27 Dulux L max 173mm	3x60 3x23			
4894*	2G11	2x18			
4424*	Emergenza 1h Emergency 1h	2G11			



Antivandalo | **Vandalproof**

Code + Colour + Tonality

CODE	LAMP	W	Im Nominali - Real output	GR	GM	+
4832*	Led	25	2500 1158			
4438*	Led + Emergenza 3h Emergency 3h	25	2500/400 1158/154			
4836*	Led + Illuminazione intelligente Intelligent illumination	25	2500 1158			
4441*	Led + Illuminazione intelligente+ Emergenza Intelligent illumination+ Emergency	25	2500/400 1158/154			

Emergenza: SA 1h; per Led: SA 3h.
Illuminazione intelligente (vedi pag. 283).
IP 65 / Classe II : cod. 4890/
IK 10
CRI 80 / Driver IN / 500 mA
230V / 50 Hz **CE**
Tonaltà **3000K o 4000K. Aggiungere 3K
o 4K al codice dopo il colore.**

Emergency: maintained lighting 1h; Led:
maintained lighting 3h.
Intelligent illumination (see page 283).
IP 65 / Class II : code 4890/
IK 10
CRI 80 / Driver IN / 500 mA
230V / 50 Hz **CE**
Color temperature available **3000K or
4000K. Add 3K or 4K to the code after
the color.**

BL Codice colore della base
Housing colour

VE Codice colore della base
Housing colour

OP Codice colore della base
Housing colour

GR GM Codice colore anello
Ring colour



JACK - JACK LED

PLAFONIERE APPLIQUES CON MASCHERE INTERCAMBIABILI
WALL/CEILING MOUNT WITH INTERCHANGEABLE MASKS

La lampada nata da una nuova concezione nell'assemblaggio. Il corpo lampada (tondo o ovale) è costituito da un insieme a tenuta stagna che contiene la base, la sorgente luminosa, il cablaggio, la coppa in vetro e la cornice di chiusura mentre il look finale è caratterizzato dalle apposite "maschere", che vanno inserite con un semplice scatto. Disponibili in forme e colori diversi, le maschere possono essere sostituite in qualsiasi momento; la lampada può così assumere, di volta in volta, una sua nuova personalità. La serie JACK è completata dalle versioni con Led di potenza di 1420 Lumen che, oltre all'illuminazione continua, offrono interessanti funzioni che assolvono alle esigenze di illuminazione d'emergenza, temporizzata, notturna o di passaggio con rilevatore incorporato. La serie JACK permette al progettista e all'installatore di risolvere con un'unica serie coordinata l'illuminazione di luce scale, scantinati, corridoi, balconi, esterni e giardini per uso residenziale o pubblico.

A lamp born from a new concept of installation. The lamp body (round or oval) consists of a watertight system of a base, light source, wiring, glass diffuser and glass retaining trim. You can achieve the final desired look by changing the front snap-on "masks". The masks, available in different shapes and colours, can be replaced at any time, allowing the lamp to take on a new personality at each change. The JACK series is completed with versions with 1420 Lumen power LEDs with, in addition to continuous illumination, offer interesting functions that fulfil emergency, timer, night dimmer, or Pir sensor lighting requirements. The JACK series gives lighting designers or installers a single coordinated series in order to illuminate stairs, basements, corridors, balconies, outdoors, and gardens for residential or public areas.



JACK - JACK LED

Plafoniere appliques
Wall/ceiling mount

Brevetto depositato
Registered patent

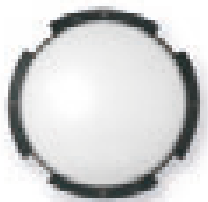

Corpo Jack Tonda
Round Jack Body

Corpo Jack Led Tonda
Round Jack Led Body

LED



Corpo Jack Ovale
Oval Jack Body

Corpo Jack Led Ovale
Oval Jack Led Body

LED

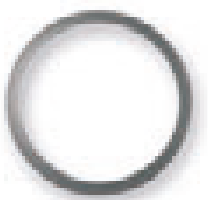

Maschere Tonda
Round Masks



Maschere Ovale
Oval Masks

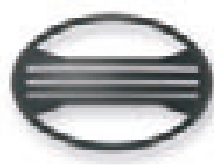



JACK

Plafoniere appliques
Wall/ceiling mount

CARATTERISTICHE GENERALI

- Plafoniera per esterno in policarbonato.
- **Struttura:** diffusore in vetro stampato, policarbonato opale IK 10 per antivandalo. Corpo in policarbonato con trattamento anti UV.
- La plafoniera è composta dalla **base** in forma tonda o ovale con relativo cablaggio, vetro e guarnizione e dalle **maschere di rivestimento** (fornite a parte) con inserimento a scatto, che determinano l'aspetto finale della lampada.
- Ingresso cavi dal retro o laterale mediante passacavo o giunto tubo/ scatola.
- **Palo** in alluminio per l'installazione in giardino.
- **Sorgenti luminose** a basso consumo.
- **Finitura:** verniciatura a spruzzo con resina poliuretanicata stabilizzata anti UV.
- Costruito in conformità alle norme europee EN 60598-1:2015 **CE**

GENERAL FEATURES

- *Polycarbonate outdoor ceiling light.*
- **Structure:** moulded glass, IK 10 vandalproof polycarbonate diffuser. Polycarbonate body with UV resistant treatment.
- *The ceiling light is composed of a round or oval shaped **base** with relative wiring, glass and gaskets and snap-insertion **covering masks** (supplied separately) to help decide the overall appearance of the lamp.*
- *Cable entry from the back or side by means of cable gland or tube/box joint.*
- *Aluminium **post** for garden installation.*
- *Energy savings **light sources**.*
- **Finish:** UV resistant stabilised polyurethane resin spray coating.
- *Manufactured in compliance with European standards EN 60598-1:2015 **CE***

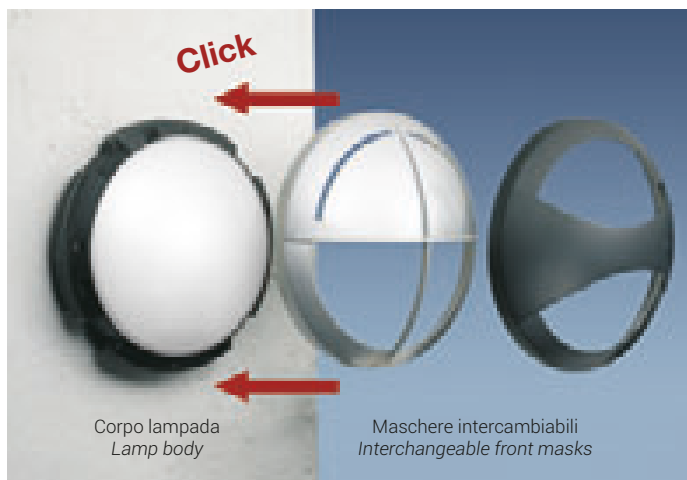

LA LAMPADA CON UNA NUOVA CONCEZIONE NELL'ASSEMBLAGGIO

Il corpo lampada è un insieme che comprende: base, lampadina, cablaggio, coppa in vetro e cornice ferma-vetro. Il corpo va installato a muro e collegato; il look finale si ottiene poi rivestendolo con apposite "maschere", inserite con un semplice scatto, disponibili in forme e colori diversi. La lampada assume così, volta per volta, una sua propria personalità. Su richiesta, le maschere possono essere realizzate in colori a campione.

A RANGE OF LUMINAIRES FEATURING A NEW ASSEMBLING CONCEPT

The body consists of a base, light source, wiring, glass diffuser and glass retaining trim. The body is then fixed to the wall and connected to the supply; you can then achieve the final look by changing the front covers (masks) which are available in different shapes and colours. Thus, each time the covers are changed, the luminaire will achieve a different personality.

PALO A "U"

Possibilità di montaggio della seconda lampada.

U-POLE

Possibility of installing 2nd light on reverse side of post.

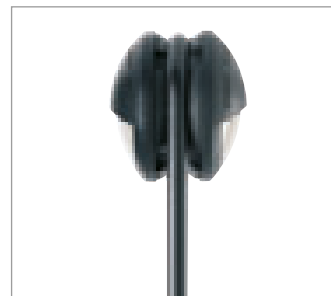

JACK

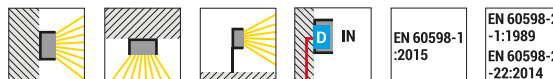

JACK CORPO OVALE | OVAL JACK BODY

Code + Colour

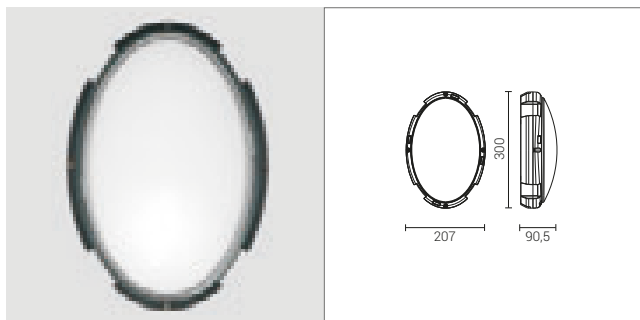

CODE	LAMP	W	NE
2241 *	E 27 Dulux El	L max 173mm 60 20	
2242 *	G23	2x9	

IP 65 / Classe II /
IK 08
CE

IP 65 / Class II /
IK 08
CE

JACK MASCHERE OVALI | OVAL JACK MASKS

Code + Colour

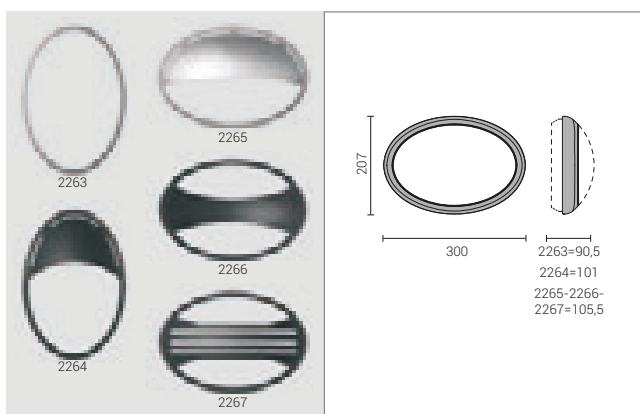

CODE	DESCRIZIONE / DESCRIPTION	BI	NE	SI
2263*	Solo maschera per Jack ovale Mask for oval Jack			
2264*	Solo maschera per Jack ovale Mask for oval Jack		NE	SI
2265*	Solo maschera per Jack ovale Mask for oval Jack			
2266*	Solo maschera per Jack ovale Mask for oval Jack			
2267*	Solo maschera per Jack ovale Mask for oval Jack			

Solo maschere in policarbonato.
Bloccaggio a scatto senza viti.
Colore bianco solo per art. 2263.
Maschere in colori a campione su richiesta.

Interchangeable masks with simple click fit to the body.
Masks only, body supplied separately.
White colour for code 2263 only. Sample colour masks are available upon request.

JACK PIANTANA CURVA | JACK INCLINED POST

Code + Colour



CODE	DESCRIZIONE / DESCRIPTION	NE
3202*	Piantana curva singola per Jack ovale Inclined post for oval Jack	

Completo di cassetta di derivazione.
Alimentazione passante consentita.
Possibilità montaggio seconda lampada.
Solo palo: apparecchio Jack fornito a parte.

Internal through wiring connection box.
Through wiring allowed.
Possibility of installing 2nd light on reverse side of post.
Post only, Jack fitting supplied separately.

La serie Jack veste l'illuminazione a Led con quattro diverse funzioni
Jack range dresses its Led inside with 4 different functions

JACK LED LUCE STANDARD | JACK LED NORMAL LIGHT



Unità Led
 Led unit
 230V / 1420 Lumen

Unità Led
 Led unit
 230V / 1000 Lumen

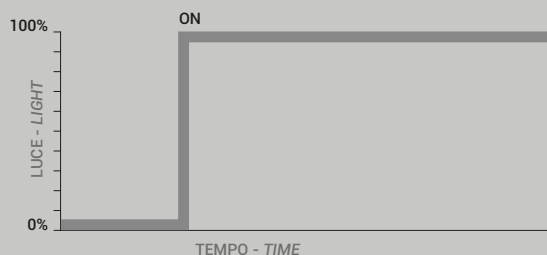

Unità Led da 1420 Lumen, 230 V. Accensione immediata. 14W consumo. Durata 50.000 h con decremento max del 20%.

Led unit 1420 lumen / 230V. Instant lighting on. 14W / 50.000 hours life with max decreasing of 20%.

JACK LED LUCE STANDARD + EMERGENZA | JACK LED MAINTAINED LIGHTING (NORMAL LIGHT + EMERGENCY)

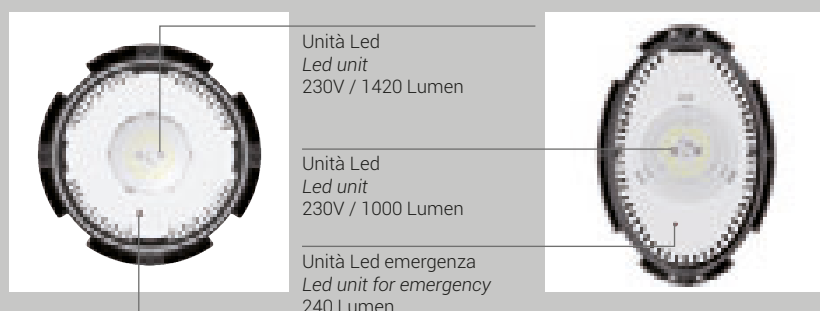

Unità Led
 Led unit
 230V / 1420 Lumen

Unità Led
 Led unit
 230V / 1000 Lumen

Unità Led emergenza
 Led unit for emergency
 240 Lumen

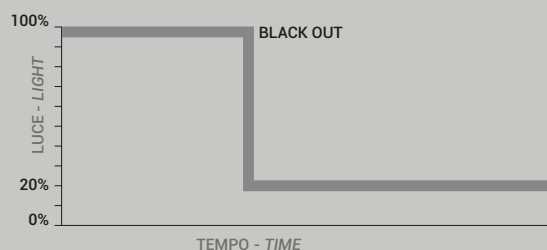

Funzionamento in S.A. (sempre accesa) innesto automatico dell'emergenza. Unità LED emergenza da 240 Lumen.

Light always on - under power or in emergency - Automatic lighting on under batteries. 240 lumen in emergency / 3 hours life.

JACK LED ILLUMINAZIONE INTELLIGENTE | JACK LED INTELLIGENT ILLUMINATION



Rilevatore di presenza
 + dimmer
 Pir Sensor Detector +
 dimmer

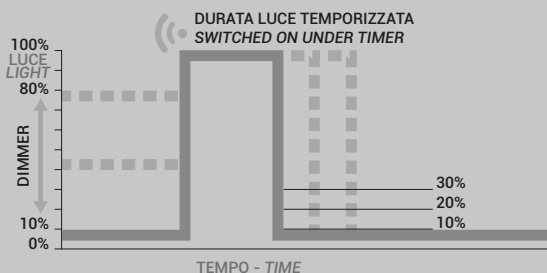

Regolazione a 0/10/20/30% della luce notturna tramite dimmer interno. Accensione a luce piena tramite rilevatore di presenza. Tre regolazioni: area rilevatore, temporizzazione, luce crepuscolare.

Adjustable night light to 0/10/20/30% by a dimmer inside and light on to 100% when the Pir Sensor detects people in the area. Three regulations: area, timer, daylight.

JACK LED ILLUMINAZIONE INTELLIGENTE + EMERGENZA | JACK LED INTELLIGENT ILLUMINATION + EMERGENCY

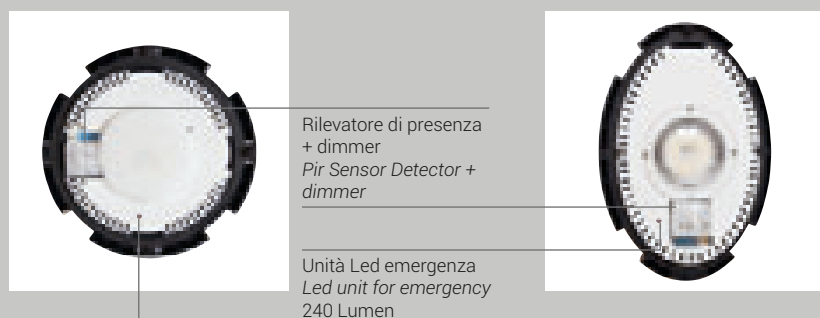

Rilevatore di presenza
 + dimmer
 Pir Sensor Detector +
 dimmer

Unità Led emergenza
 Led unit for emergency
 240 Lumen

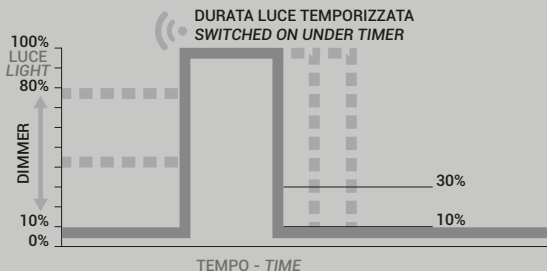

Funzionamento in S.A. (sempre accesa) innesto automatico dell'emergenza. Unità LED emergenza da 240 Lumen.

Light always on - under power or in emergency - Automatic lighting on under batteries. 240 lumen in emergency / 3 hours life.

JACK LED

Plafoniere appliques
Wall/ceiling mount

CARATTERISTICHE GENERALI

- Plafoniera della Serie JACK con applicativo Led.
- **Struttura:** diffusore in vetro stampato o policarbonato opale. Corpo in policarbonato con trattamento anti UV.
- La plafoniera è composta dalla **base** in forma tonda o ovale con relativo cablaggio, vetro e guarnizione e dalle **maschere di rivestimento** (fornite a parte) con inserimento a scatto, che determinano l'aspetto finale della lampada.
- **Palo** in alluminio per l'installazione in giardino.
- Ingresso cavi dal retro o laterale.
- **Sorgente luminosa** a Led di nuova generazione, con vita garantita 50.000 h con successivo scadimento max del 20%. Driver incorporato.
- Sono disponibili le variati con "illuminazione intelligente" (0-10-20-30% in stato di quiete con accensione automatica al 100% al passaggio) o per "emergenza SA" sempre accesa.
- **Finitura:** verniciatura a spruzzo con resina poliuretana stabilizzata anti UV.
- Costruito in conformità alle norme europee EN 60598-1:2015 **CE**

GENERAL FEATURES

- *JACK series ceiling light with LED application.*
- **Structure:** moulded glass or opal polycarbonate diffuser. Polycarbonate body with UV resistant treatment.
- *The ceiling light is composed of a round or oval shaped base with relative wiring, glass and gaskets and snap-insertion covering masks (supplied separately) to help decide the overall appearance of the lamp.*
- Aluminium **post** for garden installation.
- Cable entry from the rear or side.
- New generation LED **light source** with minimum life 50,000 h with subsequent deterioration max 20%. Driver inside.
- Variations available for "intelligent illumination" (0-10-20-30% night light with automatic ignition at 100% when sensor detects people in the area) or for "SA emergency" (light always on).
- **Finish:** UV resistant stabilised polyurethane resin spray coating.
- *Manufactured in compliance with European standards EN 60598-1:2015 **CE***

MASCHERE INTERCAMBIABILI

- 1 - 5 Maschere Intercambiabili.
- 2 - Coppa in vetro o policarbonato.
- 3 - Lente Fresnel diffondente.
- 4 - Unità Led 230V.
- 5 - Diffusore.
- 6 - Dissipatore di calore.
- 7 - O-ring.
- 8 - Base lampada.

INTERCHANGEABLE MASKS

- 1 - 5 Cover masks.
- 2 - Diffuser in glass or polycarbonate.
- 3 - Fresnel lens to 150° angle beam.
- 4 - Led Unit 230V.
- 5 - Light enlarging plate.
- 6 - Heat sink.
- 7 - O-ring.
- 8 - Fixture housing.

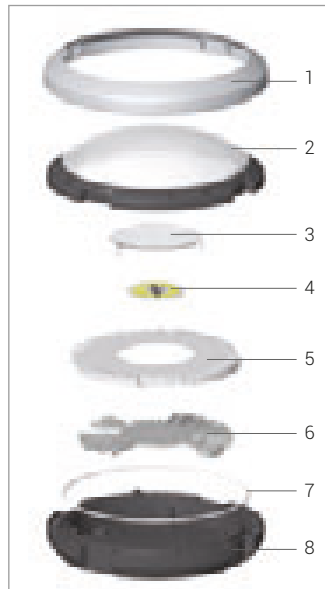

RILEVATORE DI PRESENZA + DIMMER

PIR SENSOR DETECTOR + DIMMER

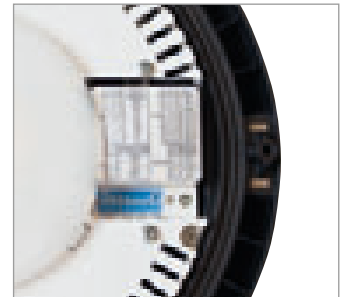

JACK LED

Plafoniere appliques
Wall/ceiling mount

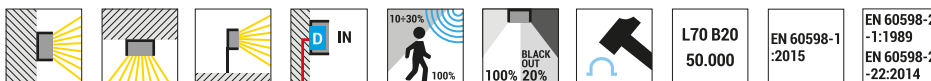

JACK LED TONDA STANDARD | ROUND JACK LED NORMAL

Code + Colour + Tonality

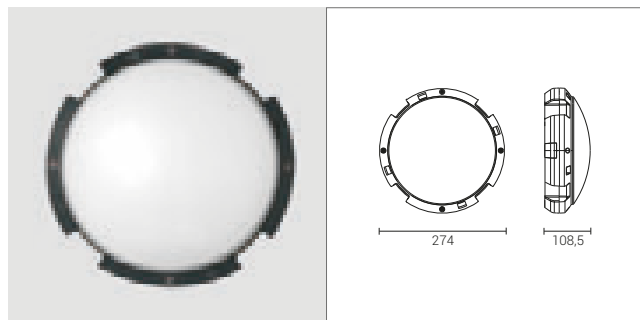

CODE LAMP W Im Nominali - Real output **NE**

2101* Led 14 1420 645

4451* Led + Emergenza 3h / Emergency 3h 14 1420/240 645/119



Antivandalo | Vandalproof

Code + Colour + Tonality

CODE LAMP W Im Nominali - Real output **NE**

2191* Led 14 1420 645

4453* Led + Emergenza 3h / Emergency 3h 14 1420/240 645/119

Emergency Led: SA 3h.
IP 65 / Classe II / IK 08 - IK 10
CRI 80 / Driver IN
230V / 50 Hz
CE
Tonalità 3000K o 4000K. Aggiungere 3K o 4K al codice dopo il colore.

Emergency Led: maintained lighting 3h.
IP 65 / Classe II / IK 08 - IK 10
CRI 80 / Driver IN
230V / 50 Hz
CE
Color temperature available 3000K or 4000K. Add 3K or 4K to the code after the color.

JACK LED TONDA ILLUMINAZIONE INTELLIGENTE | ROUND JACK LED INTELLIGENT ILLUMINATION

Code + Colour + Tonality

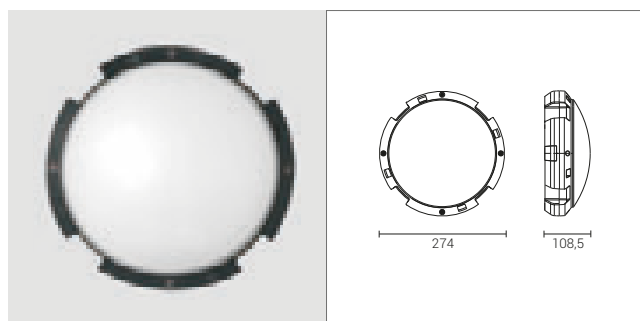

CODE LAMP W Im Nominali - Real output **NE**

2105* Led + Illuminazione intelligente / Intelligent illumination 14 1420 645

4301* Led + Illuminazione intelligente+ Emergenza / Intelligent illumination+ Emergency 14 1420/240 645/119



Antivandalo | Vandalproof

Code + Colour + Tonality

CODE LAMP W Im Nominali - Real output **NE**

2195* Led + Illuminazione intelligente / Intelligent illumination 14 1420 645

4302* Led + Illuminazione intelligente+ Emergenza / Intelligent illumination+ Emergency 14 1420/240 645/119

Illuminazione intelligente (vedi pag. 294).
IP 65 / Classe II / IK 08 - IK 10
CRI 80 / Driver IN
230V / 50 Hz
CE
Tonalità 3000K o 4000K. Aggiungere 3K o 4K al codice dopo il colore.

Intelligent illumination (see page 294).
IP 65 / Classe II / IK 08 - IK 10
CRI 80 / Driver IN
230V / 50 Hz
CE
Color temperature available 3000K or 4000K. Add 3K or 4K to the code after the color.



Illuminazione intelligente
Intelligent illumination

Illuminazione intelligente + Emergenza
Intelligent illumination + Emergency



Disponibili n. 5 maschere in policarbonato (vedi Serie Jack).
5 polycarbonate cover masks available (go to Jack range).

JACK LED

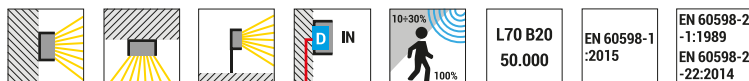

JACK LED OVALE STANDARD | OVAL JACK LED NORMAL

Code + Colour + Tonality

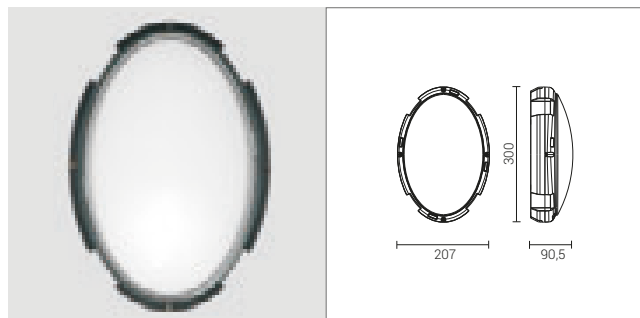

CODE	LAMP	W	Im	Nominali-Real output	NE
2143*	Led	13	1000	539	

IP 65 / Classe II / IK 08
CRI 80 / Driver IN
230V / 50 Hz

CE
Tonality 3000K or 4000K. Add 3K or 4K to the code after the color.

IP 65 / Class II / IK 08
CRI 80 / Driver IN
230V / 50 Hz

CE
Color temperature available 3000K or 4000K. Add 3K or 4K to the code after the color.

JACK LED OVALE ILLUMINAZIONE INTELLIGENTE | OVAL JACK LED INTELLIGENT ILLUMINATION

Code + Colour + Tonality

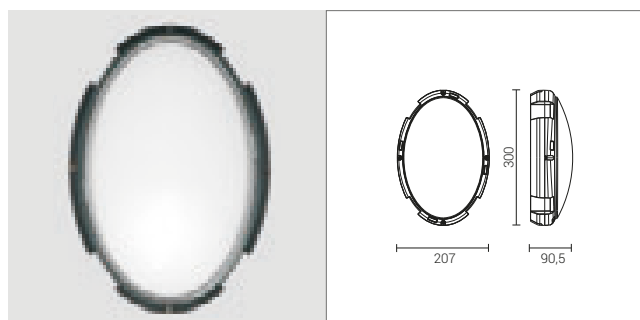

CODE	LAMP	W	Im	Nominali-Real output	NE
2146*	Led + Illuminazione intelligente Intelligent illumination	13	1000	539	

Illuminazione intelligente (vedi pag. 294).
IP 65 / Classe II / IK 08
CRI 80 / Driver IN
230V / 50 Hz

CE
Tonality 3000K or 4000K. Add 3K or 4K to the code after the color.

Intelligent illumination (see page 294).
IP 65 / Class II / IK 08
CRI 80 / Driver IN
230V / 50 Hz

CE
Color temperature available 3000K or 4000K. Add 3K or 4K to the code after the color.



Illuminazione intelligente
Intelligent illumination

Illuminazione intelligente + Emergenza
Intelligent illumination + Emergency

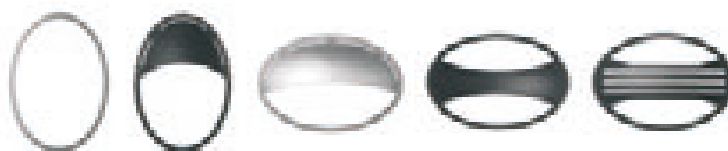

Disponibili n. 5 maschere in policarbonato (vedi Serie Jack).
5 polycarbonate cover masks available (go to Jack range).



MARINA

PLAFONIERE APPLIQUES WALL/CEILING MOUNT



Palpebra piccola
Small Palpebra



Palpebra grande
Large Palpebra



Marina ovale piccola
con griglia
Small oval Marina
with guard

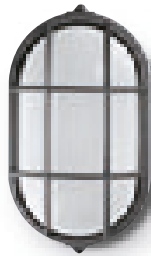

Marina ovale grande
con griglia
Large oval Marina
with guard

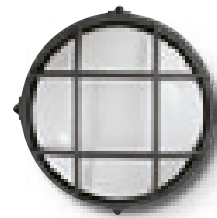

Marina tonda
con griglia
Round Marina
with guard



Marina ovale piccola
Small oval Marina



Marina ovale grande
Large oval Marina



Marina tonda
Round Marina

MARINA è un classico di Goccia Illuminazione. Solo apparentemente comune nella linea si caratterizza per la protezione IP65, il colore grafite che conferisce valenza tecnica e completa resistenza ai raggi UV, cablaggio interno anche per cavi ad alta resistenza termica e coppe in vetro o policarbonato antivandalo.

MARINA is a Goccia Illuminazione classic. Its original design is characterised by IP65 protection, a graphite colour which gives it technical value and complete resistance to UV rays, internal wiring for high-temperature resistant cables and glass or vandalproof polycarbonate diffuser.



MARINA

Plafoniere appliques
Wall/ceiling mount

CARATTERISTICHE GENERALI

- Plafoniera per esterno in policarbonato.
- **Struttura:** diffusore in vetro opale o policarbonato opale per antivandalo. Corpo, anello, griglia e palpebra in policarbonato verniciato con trattamento anti UV. Riflettore in alluminio 99,8 brillantato e precablato.
- Ingresso cavi dal retro o laterale.
- Possibile alimentazione passante.
- **Sorgenti luminose** a basso consumo.
- **Finitura:** verniciatura a spruzzo con resina poliuretanica stabilizzata anti UV.
- Costruito in conformità alle norme europee EN 60598-1:2015 **CE**

GENERAL FEATURES

- *Polycarbonate outdoor ceiling light.*
- **Structure:** *opal glass or opal polycarbonate vandalproof diffuser. Body, ring, guard and lid in painted polycarbonate with UV resistant treatment. 99.8 polished, pre-wired aluminium reflector.*
- *Cable entry from the rear or side.*
- *Through power possible.*
- *Energy savings light sources.*
- **Finish:** *UV resistant stabilised polyurethane resin spray coating.*
- *Manufactured in compliance with European standards EN 60598-1:2015 **CE***

INGRESSO CAVI POSSIBILE DA OGNI PARTE

- 1 - Dall'alto con doppia sicurezza.
- 2 - Laterale.
- 3 - Dal basso.
- 4 - Entra ed esci (alimentazione passante).
 - Con cavo
 - Con guaina e passaguaina
 - Con tubo e giunto tubo/scatola.
- 5 - Alimentazione da retro per punto-luce a parete o a soffitto.

CABLE ENTRY FROM ANY SIDE

- 1 - *From the top with double security.*
- 2 - *From the side.*
- 3 - *From the bottom.*
- 4 - *Two ways through installation.*
 - *by cable*
 - *by flexible or rigid conduit adaptor.*
- 5 - *From the rear for wall or ceiling installation.*

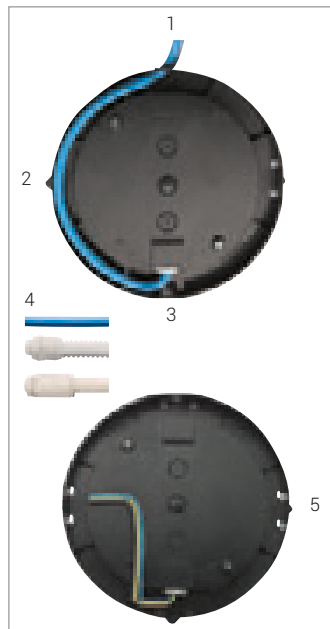

CABLAGGIO FACILITATO

EASY CONNECTION



NUOVI VETRI

Coppa in vetro prismato e verniciato.

NEW GLASS

Prismatic and satined glass diffuser



IP 65

Ingresso cavi dal retro o laterale mediante il bocchettone fornito o giunto chiudi guaina o giunto tubo-scatoia.

IP 65

Cable entry from either the rear or the side through flexible conduit or rigid conduit adaptor.



VERSIONE A INCANDESCENZA

Nella versione incandescenza delle palpebre, il riflettore in alluminio 99,8 lucidato a specchio convoglia la luce verso il basso.

INCANDESCENCE VERSION

In the incandescence version of Palpebra a new small reflector saves the light and directs it downwards.



MARINA

Plafoniere appliques
Wall/ceiling mount



PALPEBRA

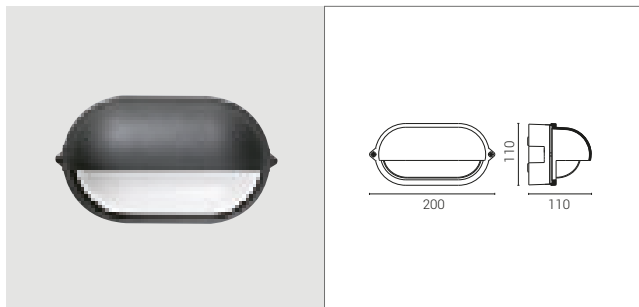

Per il modello a incandescenza riflettore in alluminio 99,8 brillantato atto a convogliare la luce verso il basso.

Per versione Antivandalo su richiesta si forniscono viti inox PIN-ESAGO con antisvitto e relativa chiave.

IP 65 / IK 08 - IK 10 / Classe I

IK 08 - IK 10

230V / 50 Hz

CE

In the incandescence version a small reflector directs the light downwards.

Vandalproof version: PIN-ESAGO stainless steel vandalproof screw and its key available on request.

IP 65 / IK 08 - IK 10 / Class I

IK 08 - IK 10

230V / 50 Hz

CE

Code + Colour

CODE	LAMP	W	GR	BI
2806*	E 27 Dulux EI L max 117mm	60 11		
2813*	G24d-1	13		

Code + Colour

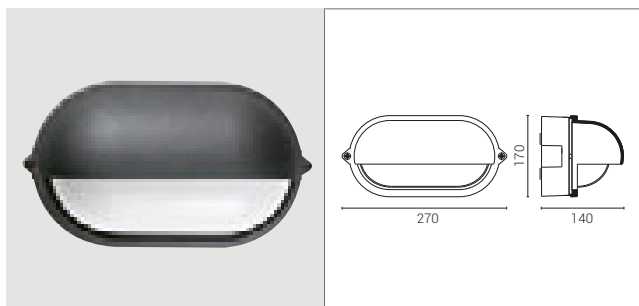

CODE	LAMP	W	GR	BI
2825*	E 27 Dulux EI L max 173mm	100 23		
2849*	G23	2x9		
2846*	G24d-3	26		



Antivandalo | Vandalproof

Code + Colour

CODE	LAMP	W	GR	BI
2895*	E 27 Dulux EI L max 173mm	75 23		
2898*	G23	2x9		
2896*	G24d-3	26		

MARINA



EN 60598-1
:2015

EN 60598-2
-1:1989

MARINA OVALE CON GRIGLIA | OVAL MARINA WITH GUARD

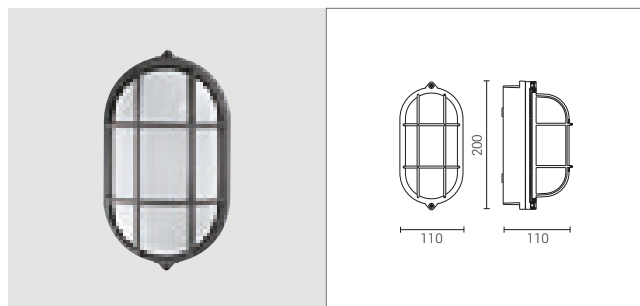

Per versione Antivandalo su richiesta si forniscono viti inox PIN-ESAGO con antivito e relativa chiave.

IP 65 / Classe I
IK 08 - IK 10
230V / 50 Hz
CE

Vandalproof version: PIN-ESAGO stainless steel vandalproof screw and its key available on request.

IP 65 / Class I
IK 08 - IK 10
230V / 50 Hz
CE

Code + Colour

CODE	LAMP		W
4510*	E 27 Dulux EI	L max 117mm	60 11
4513*	G24d-1		13

GR BI

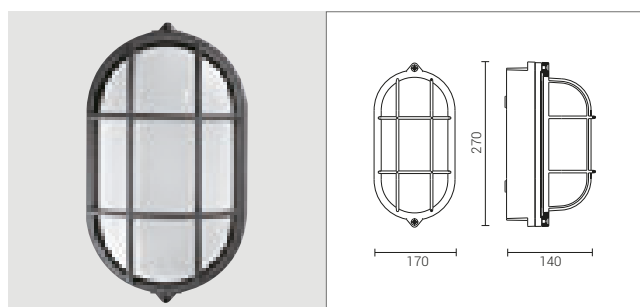

Code + Colour

CODE	LAMP		W
4520*	E 27 Dulux EI	L max 173mm	100 23
4549*	G23		2x9
4546*	G24d-3		26

GR BI



Antivandalo | Vandalproof

Code + Colour

CODE	LAMP		W
4590*	E 27 Dulux EI	L max 173mm	75 23
4598*	G23		2x9
4596*	G24d-3		26

GR BI

MARINA OVALE SENZA GRIGLIA | OVAL MARINA WITHOUT GUARD

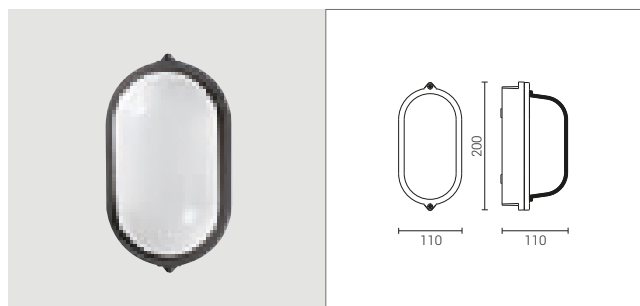

Code + Colour

CODE	LAMP		W
4560*	E 27 Dulux EI	L max 117mm	60 11
4566*	G24d-1		13

GR BI



Code + Colour

CODE	LAMP		W
4580*	E 27 Dulux EI	L max 173mm	100 23
4589*	G23		2x9
4586*	G24d-3		26

GR BI



Antivandalo | Vandalproof

Code + Colour

CODE	LAMP		W
4592*	E 27 Dulux EI	L max 173mm	75 23
4594*	G23		2x9
4593*	G24d-3		26

GR BI

MARINA

Plafoniere appliques
Wall/ceiling mount



MARINA TONDA CON GRIGLIA | ROUND MARINA WITH GUARD

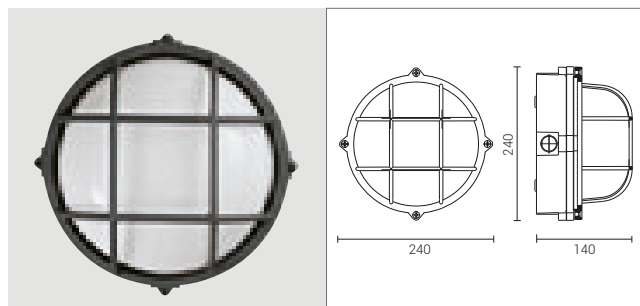

Cod. 4447 - 4497 autonomia 1h/3h.
Per versione Antivandalo su richiesta
si forniscono viti inox PIN-ESAGO con
antisvitto e relativa chiave.
IP 65 ▲▲▲ / Classe I
IK 08 - IK 10
230V / 50 Hz
CE

Code 4447 - 4497 1h/3h life .
Vandalproof version: PIN-ESAGO
stainless steel vandalproof screw and its
key available on request.
IP 65 ▲▲▲ / Class I
IK 08 - IK 10
230V / 50 Hz
CE

Code + Colour

CODE	LAMP		W	GR	BI
4720*	E 27 Dulux EI	L max 145mm	100 20		
4749*	G23		2x9		
4746*	G24d-3		26		
4742*	G24d-3		2x26		
4447*	Emergenza Emergency	2G7	2x9		



Antivandalo | Vandalproof

Code + Colour

CODE	LAMP		W	GR	BI
4790*	E 27 Dulux EI	L max 145mm	75 20		
4798*	G23		2x9		
4796*	G24d-3		26		
4497*	Emergenza Emergency	2G7	2x9		

MARINA TONDA SENZA GRIGLIA | ROUND MARINA WITHOUT GUARD

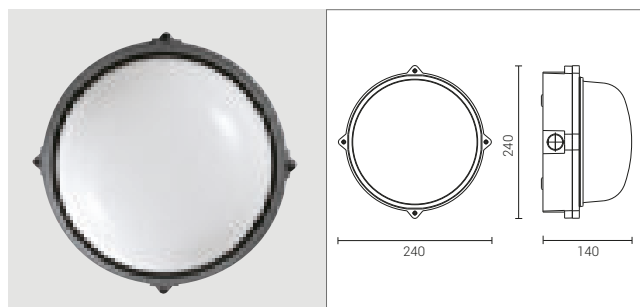

CODE	LAMP		W	GR	BI
4780*	E 27 Dulux EI	L max 145mm	100 20		
4789*	G23		2x9		
4786*	G24d-3		26		
4782*	G24d-3		2x26		
4444*	Emergenza Emergency	2G7	2x9		



Antivandalo | Vandalproof

Code + Colour

CODE	LAMP		W	GR	BI
4792*	E 27 Dulux EI	L max 145mm	75 20		
4793*	G23		2x9		
4794*	G24d-3		26		
4496*	Emergenza Emergency	2G7	2x9		

Cod. 4444 - 4496 autonomia 1h/3h.

Code 4444 - 4496 1h/3h life .





MAGNUM

PLAFONIERE APPLIQUES
WALL/CEILING MOUNT

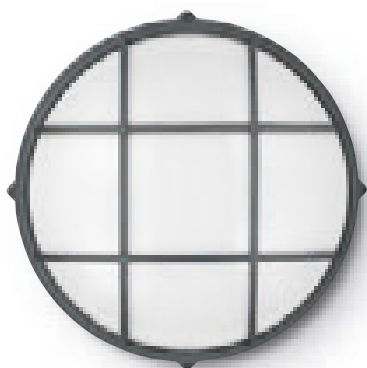

Magnum con griglia
Magnum with guard

LED



Magnum senza griglia
Magnum without guard

LED

Realizzate con gli stessi materiali della serie Marina, le plafoniere della serie MAGNUM offrono le medesime caratteristiche di resistenza e finitura. La serie MAGNUM grazie al diametro di 350 mm è indicata per l'installazione a soffitto o dove è richiesta un'illuminazione forte e diffusa. La nuova versione con Led di potenza offre diverse interessanti funzioni.

Produced from the same materials as the Marina, the MAGNUM range, with or without guard, provides a bright, attractive and effective diffused wall and ceiling fitting. MAGNUM dimensions are the right ones to contain a lot of lighting sources, power energy saving lamps, emergency units and electronic ballasts. And of course a new generation led unit with some interesting versions.

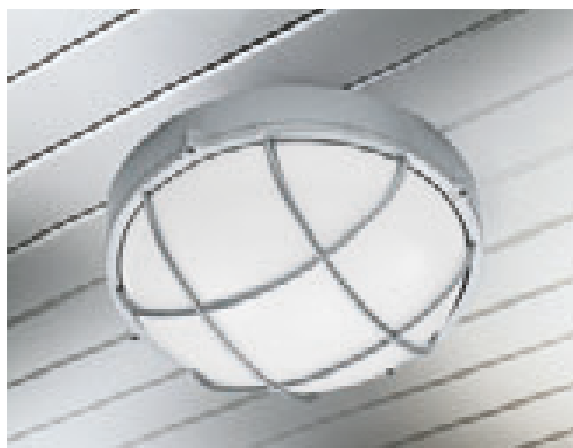

MAGNUM

Plafoniere appliques
Wall/ceiling mount

CARATTERISTICHE GENERALI

- Plafoniera ø 350 mm per esterno.
- **Struttura:** diffusore in policarbonato opale anti UV. Corpo, cornice fermavetro e griglia in policarbonato.
- Ingresso cavi dal retro.
- **Sorgenti luminose** ad alto rendimento e basso consumo o Led di nuova generazione con vita garantita 50.000 h con successivo scadimento max del 20%. Driver incorporato.
- Per l'applicazione a Led sono disponibili le varianti con "illuminazione intelligente" (0-10-20-30% in stato di quiete con accensione automatica al 100% al passaggio) o per "emergenza SA" sempre accesa.
- **Finitura:** verniciatura a spruzzo con resina poliuretanica stabilizzata anti UV.
- Costruito in conformità alle norme europee EN 60598-1:2015 **CE**

GENERAL FEATURES

- *Outdoor ceiling light diam. 350 mm.*
- **Structure:** *opal polycarbonate UV resistant diffuser. Polycarbonate body, glazing bead frame and guard.*
- *Cable entry from the back.*
- *High performance, low consumption light sources or new generation LEDs with minimum life 50,000 h with subsequent deterioration max 20%. Driver inside.*
- *Variations for LED application available with "intelligent illumination" (0-10-20-30% night light with automatic ignition at 100% when sensor detects people in the area) or for "SA emergency" (light always on).*
- **Finish:** *UV resistant stabilised polyurethane resin spray coating.*
- *Manufactured in compliance with European standards EN 60598-1:2015 CE*

MAGNUM LED

LUCE STANDARD

Unità Led da 2500 Lumen / 230V / 25W.
Driver 230V incorporato. Accensione immediata. Durata 50.000 h con decremento max del 20%.

LUCE STANDARD+EMERGENZA

Funzionamento in S.A. (sempre accesa), innesto automatico dell'emergenza.

1 - Unità Led 230V/2500 Lumen.

STANDARD LIGHT

Led unit 2500 lumen / 230V driver inside / 25W / CRI 80. Instant start. Life 50.000 hours with max decreasing of 20%.

STANDARD LIGHT + EMERGENCY

Maintained light function. The light comes on automatically after black-out.

1 - Led unit 230V/2500 Lumen.



ILLUMINAZIONE INTELLIGENTE

Regolazione a 0/10/20/30% della luce notturna tramite dimmer interno. Accensione a luce piena tramite rilevatore di presenza. Tre regolazioni: area rilevatore, temporizzazione, luce crepuscolare.

1 - Rilevatore di presenza + dimmer per illuminazione intelligente.

2 - Unità Led 230V/2500 Lumen.

INTELLIGENT ILLUMINATION

Adjustable night light to 0/10/20/30% by a dimmer inside and light on to 100% when the Pir Sensor detects people in the area. Three regulations: area, timer, daylight.

1 - Pir Sensor Detector + dimmer for intelligent illumination.

2 - Led unit 230V/2500 Lumen.

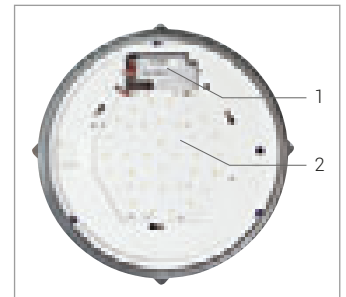

MAGNUM



MAGNUM CON GRIGLIA | MAGNUM WITH GUARD

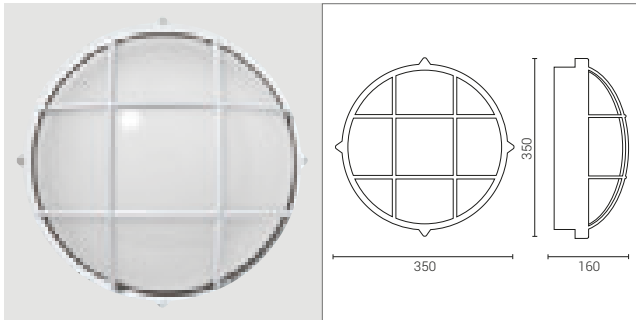

Antivandalo | Vandalproof

Code + Colour

CODE	LAMP	W	GR	BI
2395*	E 27 Dulux EI	L max 173mm 2x60 2x23		
2397*	2G11	2x18		
2399*	Alimentaz. elettronica Electronic ballast	Gx24q-4		
4493*	Emergenza 1h Emergency 1h	2G11		



Antivandalo | Vandalproof

Code + Colour + Tonality

CODE	LAMP	W	Im Nominali	Real output	GR	BI
2380*	Led	25	2500	1158		
4448*	Led + Emergenza 3h Emergency 3h	25	2500/400	1158/154		
2386*	Led + Illuminazione intelligente Intelligent illumination	25	2500	1158		
4442*	Led + Illuminazione intelligente+ Emergenza Intelligent illumination+ Emergency	25	2500/400	1158/154		

Illuminazione intelligente (vedi pag. 308).
Per cod. 2399 utilizzare soltanto lampadine ad amalgama.
IP 65 / Classe I / IK 10
CRI 80 / Driver IN / 500 mA
230V / 50 Hz **CE**
Tonalità 3000K o 4000K. Aggiungere 3K o 4K al codice dopo il colore.

Intelligent illumination (see page 308).
Code 2399: utilize only amalgam lamps.
IP 65 / Class I / IK 10
CRI 80 / Driver IN / 500 mA
230V / 50 Hz **CE**
Color temperature available 3000K or 4000K. Add 3K or 4K to the code after the color.

MAGNUM SENZA GRIGLIA | MAGNUM WITHOUT GUARD

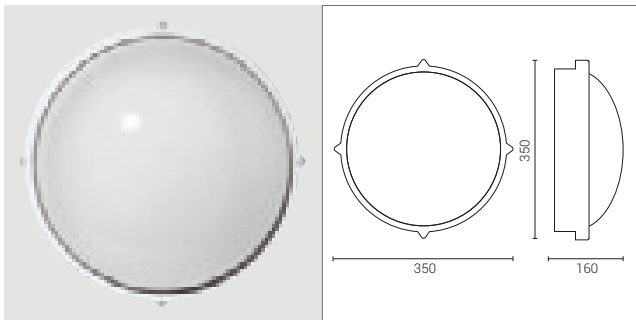

Antivandalo | Vandalproof

Code + Colour

CODE	LAMP	W	GR	BI
2495*	E 27 Dulux EI	L max 173mm 2x60 2x23		
2497*	2G11	2x18		
2499*	Alimentaz. elettronica Electronic ballast	Gx24q-4		
4494*	Emergenza 1h Emergency 1h	2G11		



Antivandalo | Vandalproof

Code + Colour + Tonality

CODE	LAMP	W	Im Nominali	Real output	GR	BI
2481*	Led	25	2500	1158		
4449*	Led + Emergenza 3h Emergency 3h	25	2500/400	1158/154		
2488*	Led + Illuminazione intelligente Intelligent illumination	25	2500	1158		
4443*	Led + Illuminazione intelligente+ Emergenza Intelligent illumination+ Emergency	25	2500/400	1158/154		

Illuminazione intelligente (vedi pag. 308).
Per cod. 2499 utilizzare soltanto lampadine ad amalgama.
IP 65 / Classe I / IK 10
CRI 80 / Driver IN / 500 mA
230V / 50 Hz **CE**
Tonalità 3000K o 4000K. Aggiungere 3K o 4K al codice dopo il colore.

Intelligent illumination (see page 308).
Code 2499: utilize only amalgam lamps.
IP 65 / Class I / IK 10
CRI 80 / Driver IN / 500 mA
230V / 50 Hz **CE**
Color temperature available 3000K or 4000K. Add 3K or 4K to the code after the color.



SUMMERTIME

LAMPADE PER OMBRELLONI
LUMINAIRES FOR BIG UMBRELLAS



Diffusore a sfera
Spherical diffuser

SUMMERTIME è la soluzione ideale per illuminare tavolini esterni di bar e ristoranti, per il Vostro ombrellone in giardino e dovunque esista un palo, un tronco o un quadro su cui fissarla. È un apparecchio removibile che si aggancia e si sgancia con facilità su pali da 38 a 70 mm. SUMMERTIME è una solida struttura interamente in policarbonato resistente ai raggi UV senza viti a vista.

SUMMERTIME is the perfect solution for the illumination of external tables in bars and restaurants, for your garden umbrellas or wherever there is a post, a tree branch or even a square post on which you can attach it. It is a removable fitting which can be easily fixed and removed from any post from 38 to 70 mm thickness. SUMMERTIME, a robust electrical appliance, thoroughly in UV resistant polycarbonate, without visible screws.



SUMMERTIME

Lampade per ombrelloni
Luminaires for big umbrellas

CARATTERISTICHE GENERALI

- Lampada portatile per ombrelloni.
- **Struttura:** interamente in policarbonato RAL 9001 irrobustita mediante saldatura a ultrasuoni e per vibrazione. Nessuna vite a vista. Viti, bulloni e dadi inox. Globi in acrilico. Ganasce sovrastampate in gomma morbida.
- Cablaggio interno preformato e fuori portata
- Ingresso cavi nell'apposito vano tramite passacavo.
- L'apparecchio è agganciabile con un semplice clack a qualunque tipo di palo da \varnothing 38 a \varnothing 70 mm.
- **Sorgenti luminose:** per lampadine Led o basso consumo lunghezza max. 145 mm.
- Costruito in conformità alle norme europee EN 60598-1:2015 **CE**

GENERAL FEATURES

- Portable lamp for sunshades.
- **Structure:** entirely in RAL 9001 polycarbonate strengthened through ultrasound welding and special process of vibration. No visible screws. Stainless steel screws, bolts, and nuts. Acrylic spherical diffusers. Clamps in soft rubber.
- Internal pre-shaped and out of reach wiring.
- Cable entry in special space through cable gland.
- Fitting can be hooked with a simple click to any type of post, from 38 to 70 mm diameter.
- **Light sources:** for LED or energy saving bulbs max length 145 mm.
- Manufactured in compliance with European standards EN 60598-1:2015 **CE**

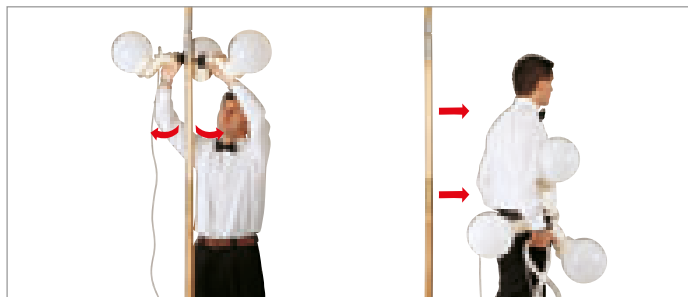

RIMOZIONE

La rimozione è semplice.

REMOVAL

Easy removal.

AGGANCIAMENTO UNIVERSALE

Si monta su pali tondi o quadrati con diametro o lato da 38 a 70 mm, e togliendo le ganasce, fino a pali di \varnothing 90 mm.

UNIVERSAL CLAMPING

Summertime can be attached to round or square posts from 38mm to 70mm thickness, and by removing the internal clamps to a post of 90mm diameter.

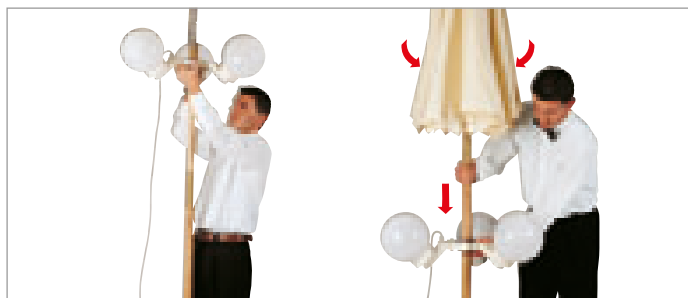
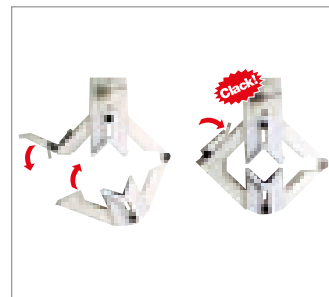

AGGANCIAMENTO SCORREVOLE

Scorre in basso per facilitare la chiusura dell'ombrellone.

SLIDE CLAMPING

Summertime can slide downward to allow the umbrellas closure.



SUMMERTIME DIFFUSORE A SFERA | SUMMERTIME SPHERICAL DIFFUSER

Code + Colour

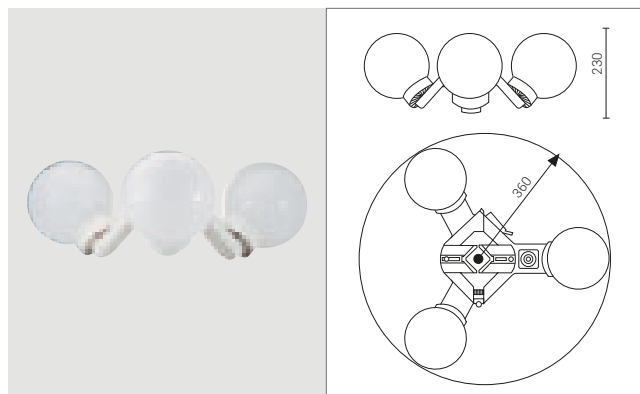

CODE	LAMP		W	RAL
2933	E 27 Dulux EI	L max 145mm	3x40 3x20	9001

Cavo di collegamento non compreso.

IP 55 / Classe I

IK 10

230V / 50 Hz

CE

Connecting cable not included.

IP 55 / Class I

IK 10

230V / 50 Hz

CE





ACCENSIONI INDIPENDENTI | *INDIVIDUAL CONTROL*

APPLICAZIONI PER VANI SCALA *STAIRS LIGHT*



Kasko Tonda
Round Kasko



Magnum



Marina Tonda
Round Marina

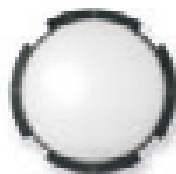

Jack Led Tonda
Round Jack Led

LED

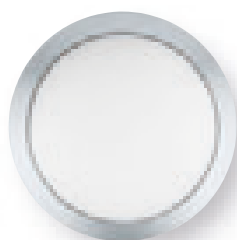

Feeling



Docks Led

LED

Per ragioni di risparmio energetico è consuetudine programmare per i vani scala due diversi livelli di illuminazione. Una luce notturna più bassa ed una luce piena temporizzata su comando manuale o automatico. Tutto questo può essere ottenuto con due sorgenti luminose tradizionali o con Led con rilevatore di presenza incorporato. Soluzione da noi definita "illuminazione intelligente".

It is useful scheduling two different light levels to save energy. The night light at low consumption when there is nobody and the full light at 100% when somebody comes in. The traditional way to do this is to install two different lighting sources. By the new led technology you can get now the same function with dimmer and Pir sensor inside. We call this function "Intelligent Illumination".

Accensioni indipendenti | Individual control

Applicazioni per vani scala
Stairs light



KASKO TONDA ACCENSIONI INDIPENDENTI | ROUND KASKO INDIVIDUAL CONTROL

Code + Colour

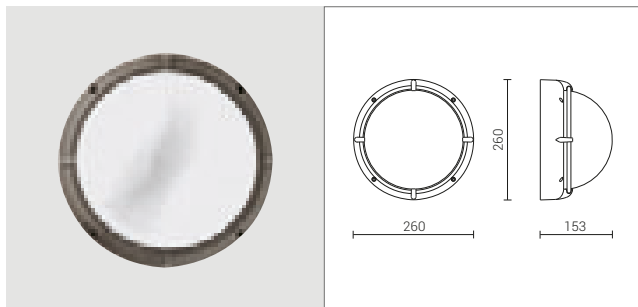

CODE	LAMP	W	BI	GR	SI
------	------	---	----	----	----

7108*	E 27 + E 14	100 + 25			
--------------	-------------	----------	--	--	--

7109*	E 27 + G24d-1	100 + 13			
--------------	---------------	----------	--	--	--



Antivandalo | Vandalproof

Code + Colour

CODE	LAMP	W	BI	GR	SI
------	------	---	----	----	----

7191*	E 27 + E 14	100 + 25			
--------------	-------------	----------	--	--	--

7192*	E 27 + G24d-1	100 + 13			
--------------	---------------	----------	--	--	--

Struttura: vedi Serie Kasko.

Luce temporizzata: 100W.

Luce notturna: 25W/13W.

Usò parete/soffitto.

Variante con luce temporizzata + notturna + emergenza a richiesta.

IP 65 / Classe I / IK 08 - IK 10

230V / 50 Hz

CE

Structure: see Kasko range.

Timer controlled light: 100W.

Lamps individually operating: 25W/13W.

Wall/ceiling mounting.

Version with timer-controlled light + lamps individually operating + emergency on request.

IP 65 / Class I / IK 08 - IK 10

230V / 50 Hz

CE

MARINA TONDA ACCENSIONI INDIPENDENTI | ROUND MARINA INDIVIDUAL CONTROL

Code + Colour

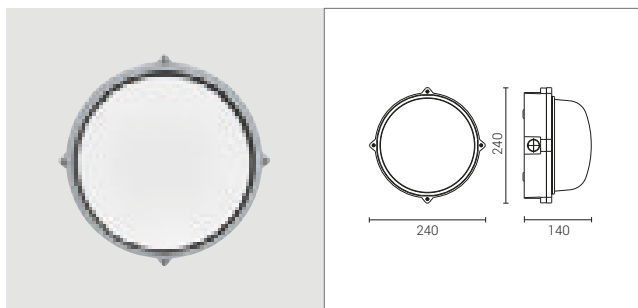

CODE	LAMP	W	GR	BI
------	------	---	----	----

7113*	E 27 + E 14	100 + 25		
--------------	-------------	----------	--	--

7114*	E 27 + G24d-1	100 + 13		
--------------	---------------	----------	--	--



Antivandalo | Vandalproof

Code + Colour

CODE	LAMP	W	GR	BI
------	------	---	----	----

7193*	E 27 + E 14	75 + 25		
--------------	-------------	---------	--	--

7194*	E 27 + G24d-1	75 + 13		
--------------	---------------	---------	--	--

Struttura: vedi Serie Marina.

Luce temporizzata: 100W/75W.

Luce notturna: 25W/13W.

Usò parete/soffitto.

Variante con luce temporizzata + notturna + emergenza a richiesta.

IP 65 / Classe I / IK 08 - IK 10

230V / 50 Hz

CE

Structure: see Marina range.

Timer controlled light: 100W/75W.

Lamps individually operating: 25W/13W.

Wall/ceiling mounting.

Version with timer-controlled light + lamps individually operating + emergency on request.

IP 65 / Class I / IK 08 - IK 10

230V / 50 Hz

CE

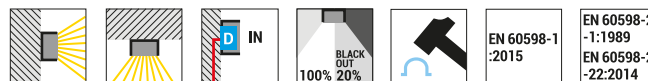

FEELING ACCENSIONI INDIPENDENTI | FEELING INDIVIDUAL CONTROL

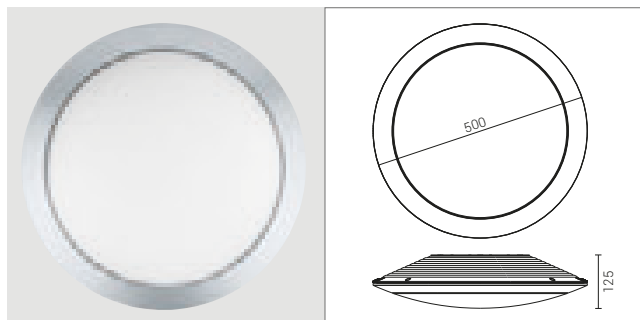

Struttura: vedi Serie Feeling.
 Luce temporizzata: 75W.
 Luce notturna: 13W.
 Uso parete/soffitto.
Variante con luce temporizzata + notturna + emergenza a richiesta.
 IP 65 / Classe I / IK 10
 230V / 50 Hz
 CE

Structure: see Feeling range.
 Timer controlled light: 75W.
 Lamps individually operating: 13W.
 Wall/ceiling mounting.
Version with timer-controlled light + lamps individually operating + emergency on request.
 IP 65 / Class I / IK 10
 230V / 50 Hz
 CE

SENZA RETROILLUMINAZIONE | WITHOUT BACK-LIGHT



Antivandalo | Vandalproof

Code + Colour

CODE	LAMP		W	GR	GM
7115*	+	E 27 + G24d-1	75 + 13		
7116*		E 27	75		
7117*	+ + + +	E 27 + G24d-1	75 + 13		
7118*	+	E 27 + G24d-1	75 + 13		

CON RETROILLUMINAZIONE | WITH BACK-LIGHT



Antivandalo | Vandalproof

Code + Colour

CODE	LAMP		W	GR	SM	+
7106*	+	E 27 + G24d-1	75 + 13			
7107*		E 27	75			
4427*	+ + + +	E 27 + G24d-1	75 + 13			
4428*	+	E 27 + G24d-1	75 + 13			



BL Codice colore della base
Housing colour



VE Codice colore della base
Housing colour



OP Codice colore della base
Housing colour

GR GM Codice colore anello
Ring colour

MAGNUM ACCENSIONI INDIPENDENTI | MAGNUM INDIVIDUAL CONTROL

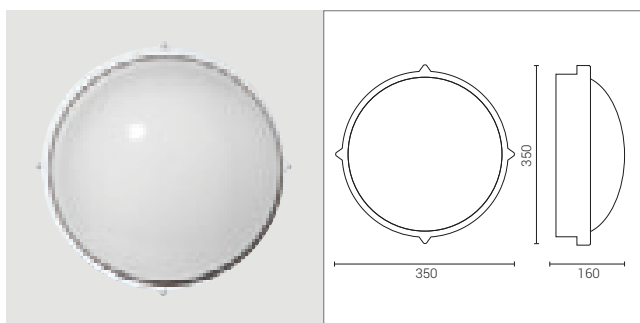

Antivandalo | Vandalproof

Code + Colour

CODE	LAMP		W	GR	BI
7111*	+	E 27 + G24d-1	60 + 13		
7112*		E 27	60		
4411*	+ + + +	E 27 + G24d-1	60 + 13		
4412*	+	E 27 + G24d-1	60 + 13		

Struttura: vedi Serie Magnum.
 Luce temporizzata: 60W.
 Luce notturna: 13W.
 Uso parete/soffitto.
 IP 65 / Classe I / IK 10
 230V / 50 Hz
 CE

Structure: see Magnum range.
 Timer controlled light: 60W.
 Lamps individually operating: 13W.
 Wall/ceiling mounting.
 IP 65 / Class I / IK 10
 230V / 50 Hz
 CE

Accensioni indipendenti | Individual control

Applicazioni per vani scala
Stairs light

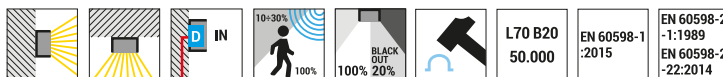

ILLUMINAZIONE INTELLIGENTE A LED | LED INTELLIGENT ILLUMINATION

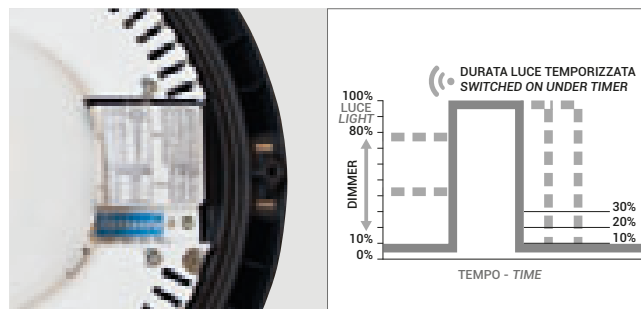

Illuminazione intelligente: regolazione a 0/10/20/30% della luce notturna tramite dimmer interno. Accensione a luce piena tramite rilevatore di presenza. Tre regolazioni: area rilevatore, temporizzazione, luce crepuscolare.

Intelligent illumination: adjustable night light to 0/10/20/30% by a dimmer inside and light on to 100% when the Pir Sensor detects people in the area. Three regulations: area, timer, daylight.

Tonalità 3000K o 4000K. Aggiungere 3K o 4K al codice dopo il colore.
Color temperature available 3000K or 4000K. Add 3K or 4K to the code after the color.

JACK LED

Code + Colour + Tonality

JACK LED TONDA | ROUND JACK LED

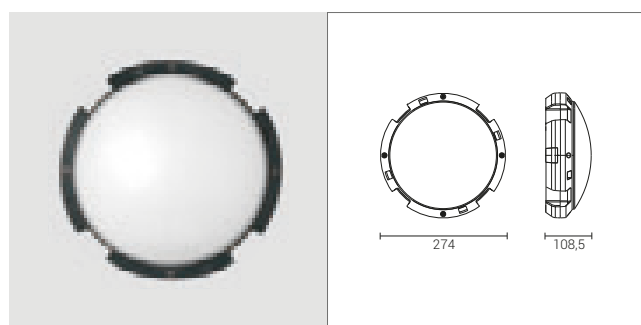

CODE LAMP W Im Nominali - Real output **NE**

2105* Led + Illuminazione intelligente Intelligent illumination 14 1420 645

4301* Led + Illuminazione intelligente+ Emergenza Intelligent illumination+ Emergency 14 1420/240 645/119



Antivandalo | Vandalproof

Code + Colour + Tonality

CODE LAMP W Im Nominali - Real output **NE**

2195* Led + Illuminazione intelligente Intelligent illumination 14 1420 645

4302* Led + Illuminazione intelligente+ Emergenza Intelligent illumination+ Emergency 14 1420/240 645/119

Code + Colour + Tonality

JACK LED OVALE | OVAL JACK LED

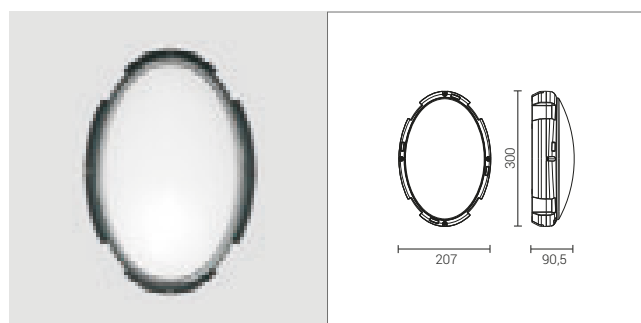

CODE LAMP W Im Nominali - Real output **NE**

2146* Led + Illuminazione intelligente Intelligent illumination 13 1000 539

Unità Led 230V inclusa. Driver non necessario. Rilevatore di presenza + dimmer incorporato. Disponibili n. 5 maschere in policarbonato (vedi Serie Jack).

Led unit 230 V inside. Driver not necessary. Pir Sensor Detector + dimmer incorporated. 5 polycarbonate cover masks available (go to Jack range).

MAGNUM LED

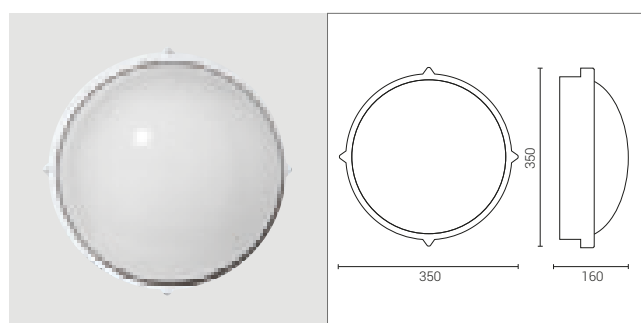

Antivandalo | Vandalproof

Code + Colour + Tonality

CODE LAMP W Im Nominali - Real output **GR** **BI**

2488* Led + Illuminazione intelligente Intelligent illumination 25 2500 1158

4443* Led + Illuminazione intelligente+ Emergenza Intelligent illumination+ Emergency 25 2500/400 1158/154



DOCKS LED

Code + Colour + Tonality

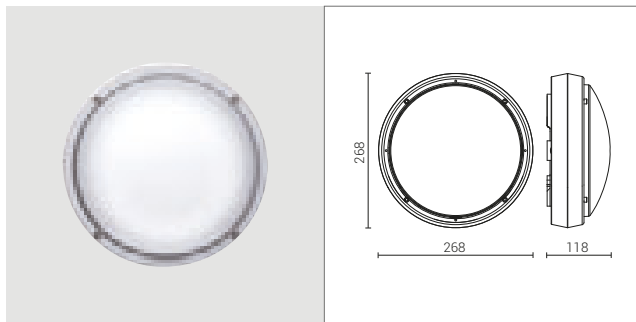

CODE LAMP W Im Nominali-Real output **GR GM BI**

9102* Led + Illuminazione intelligente
Intelligent illumination 14 1420 600



Antivandalo | Vandalproof

Code + Colour + Tonality

CODE LAMP W Im Nominali-Real output **GR GM BI**

9105* Led + Illuminazione intelligente
Intelligent illumination 14 1420 600

È possibile fornire su richiesta la versione in emergenza SA sempre accesa.

Maintained lighting emergency available on request.

KASKO LED

Code + Colour + Tonality

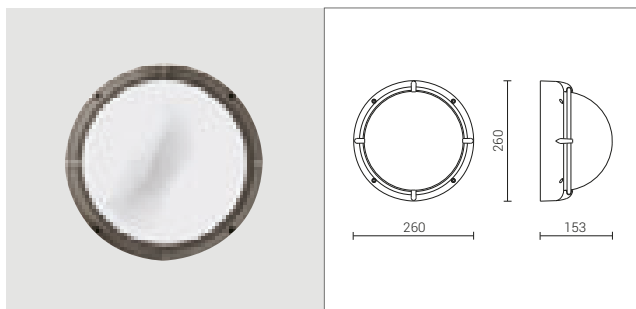

CODE LAMP W Im Nominali-Real output **BI GR SI**

9152* Led + Illuminazione intelligente
Intelligent illumination 14 1420 645



Antivandalo | Vandalproof

Code + Colour + Tonality

CODE LAMP W Im Nominali-Real output **BI GR SI**

9156* Led + Illuminazione intelligente
Intelligent illumination 14 1420 645

È possibile fornire su richiesta la versione in emergenza SA sempre accesa.

Maintained lighting emergency available on request.

FEELING LED

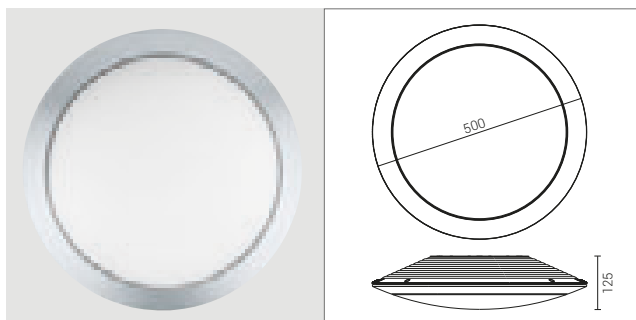

SENZA RETROILLUMINAZIONE | WITHOUT BACK-LIGHT



Antivandalo | Vandalproof

Code + Colour + Tonality

CODE LAMP W Im Nominali - Real output **GR GM**

4825* Led + Illuminazione intelligente
Intelligent illumination 25 2500 1158

4440* Led + Illuminazione intelligente+
Emergenza Intelligent illumination+
Emergency 25 2500/400 1158/154

CON RETROILLUMINAZIONE | WITH BACK-LIGHT



Antivandalo | Vandalproof

Code + Colour + Tonality

CODE LAMP W Im Nominali - Real output **GR GM + BL VE OP**

4836* Led + Illuminazione intelligente
Intelligent illumination 25 2500 1158

4441* Led + Illuminazione intelligente+
Emergenza Intelligent illumination+
Emergency 25 2500/400 1158/154

BL VE OP Codice colore della base
Housing colour

Serie Quantum

Cod. 5421+5452

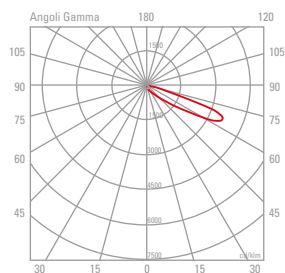

Cod. 5425+5462

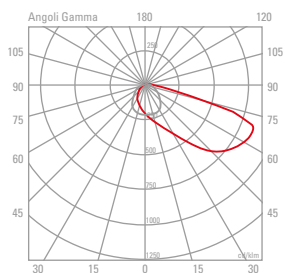

Cod. 5430+5463

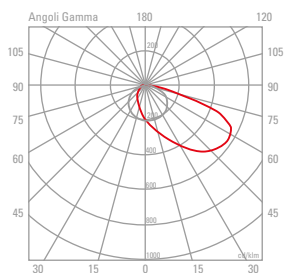

Cod. 5435+5464

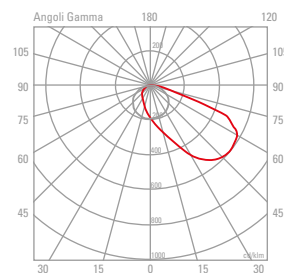

180° — 0°
90° — 270°

Cod. 5440+5465

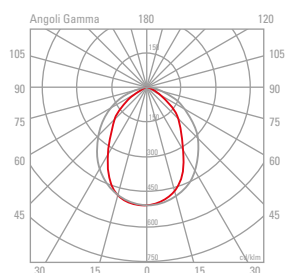

Cod. 5440+5467

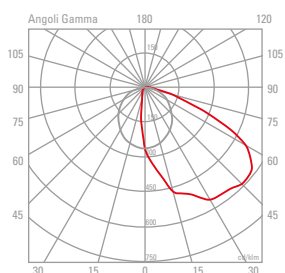

Cod. 5591

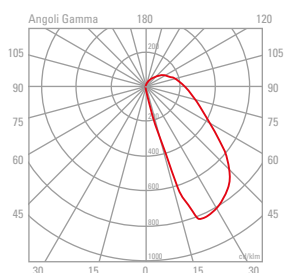

Cod. 5593

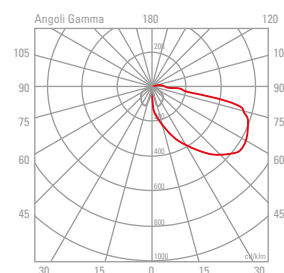

180° — 0°
90° — 270°

Serie Passum

Cod. 1401

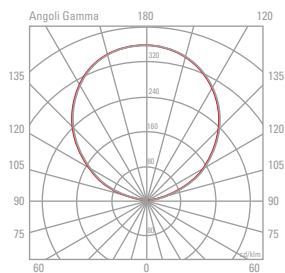

Cod. 1413 18°

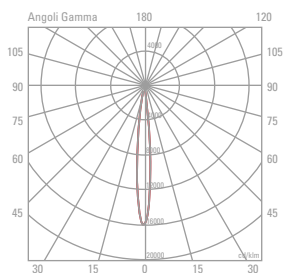

Cod. 1413 38°

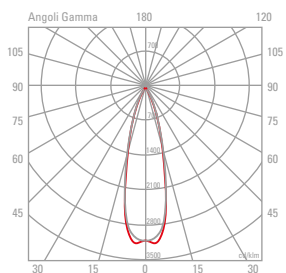

Cod. 1413 90°

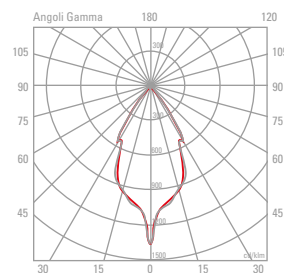

180° — 0°
90° — 270°

Cod. 1416+1515

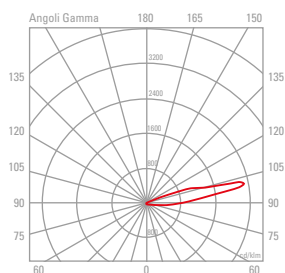

Cod. 1416+1516

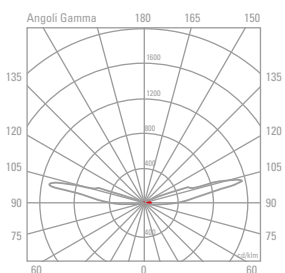

Cod. 1416+1517

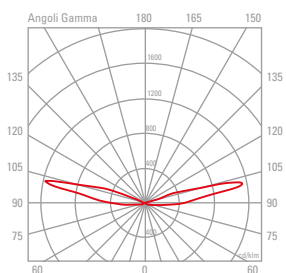

Cod. 1416+1519

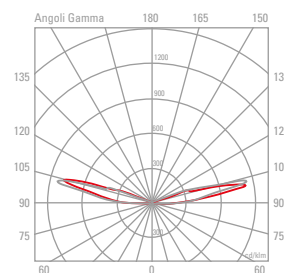

180° — 0°
90° — 270°

Serie Passum

Cod. 1422 18°

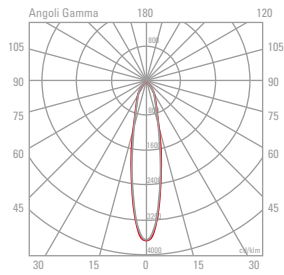

180° — 0°
90° — 270°

Cod. 1422 38°

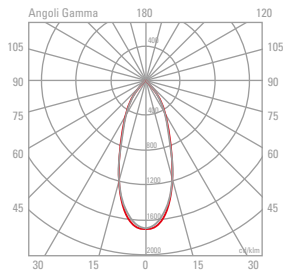

Cod. 1422 90°

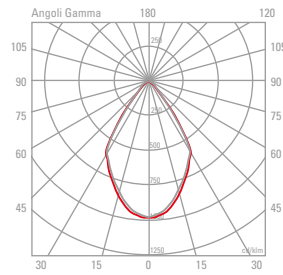

Cod. 1427+1525

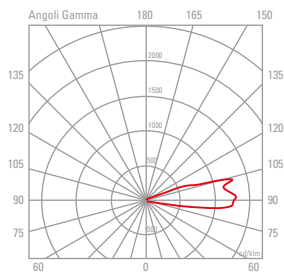

180° — 0°
90° — 270°

Cod. 1427+1526

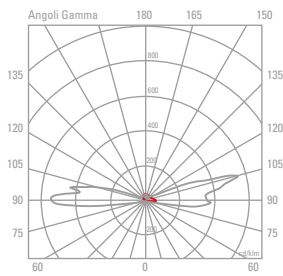

Cod. 1427+1527

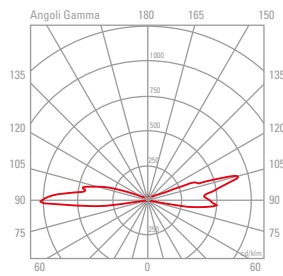

Cod. 1427+1529

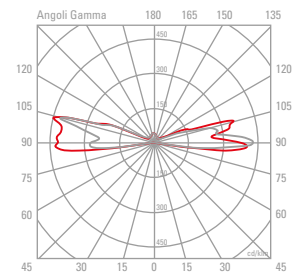

Cod. 1432 18°

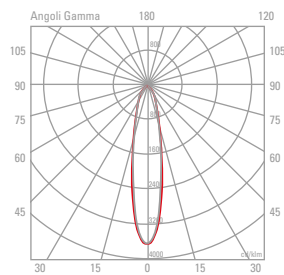

180° — 0°
90° — 270°

Cod. 1432 38°

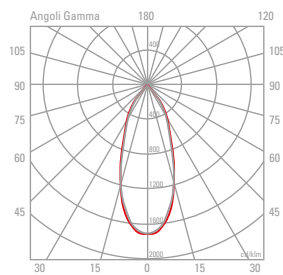

Cod. 1432 90°

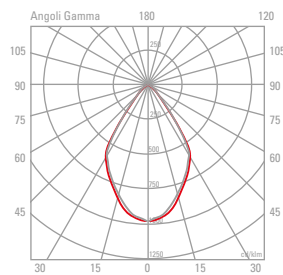

Cod. 1436+1535

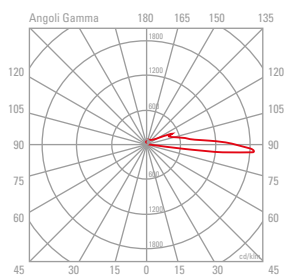

180° — 0°
90° — 270°

Cod. 1436+1536

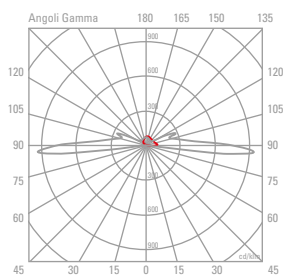

Cod. 1436+1537

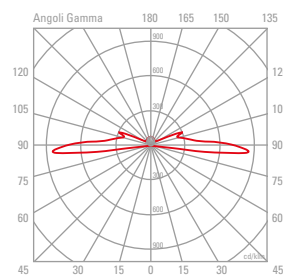

Cod. 1436+1539

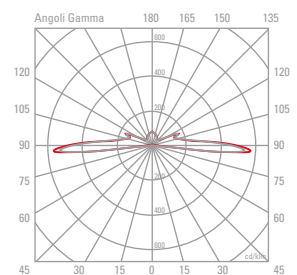

Serie Passum

Cod. 1438

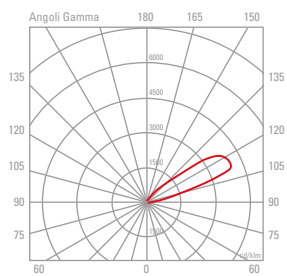

Cod. 1442 18°

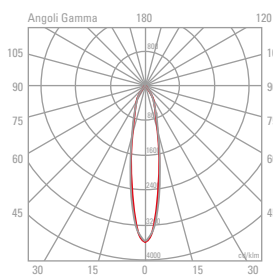

Cod. 1442 38°

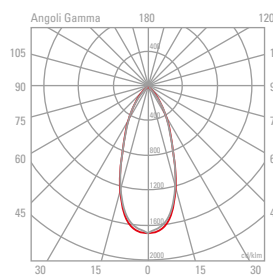

Cod. 1442 90°

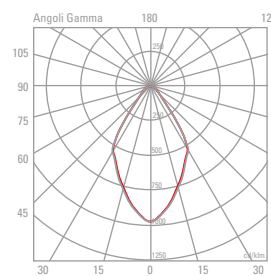

180° — 0°
90° — 270°

Cod. 1482

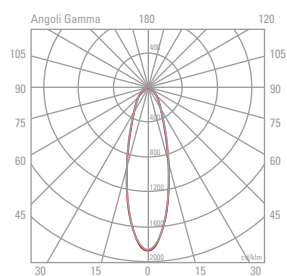

180° — 0°
90° — 270°

Serie Compatta

Cod. 5022

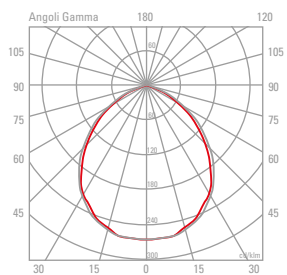

Cod. 5024

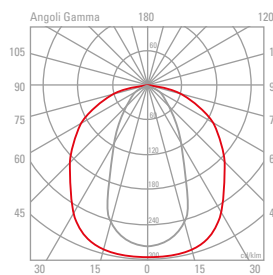

Cod. 5032

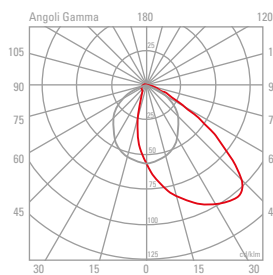

180° — 0°
90° — 270°

Serie Compatta Led

Cod. 5025 90°

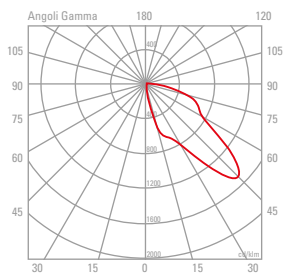

Cod. 5025 120°

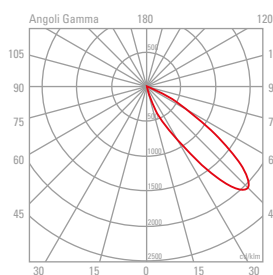

180° — 0°
90° — 270°

Serie I-Lux

Cod. 5501

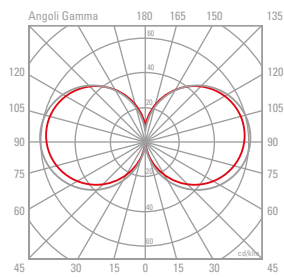

Cod. 5502

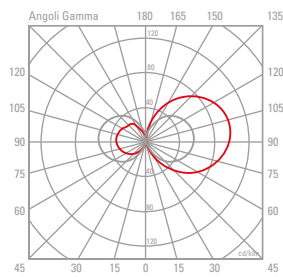

Cod. 5508

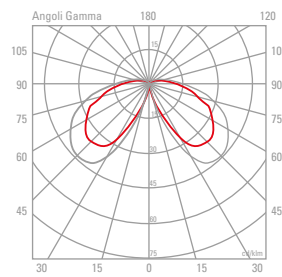

180° — 0°
90° — 270°

Serie I-Mago

Cod. 5510

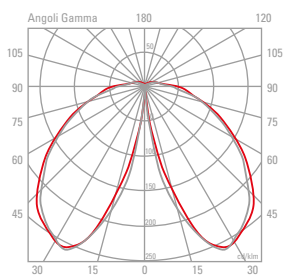

Cod. 5500

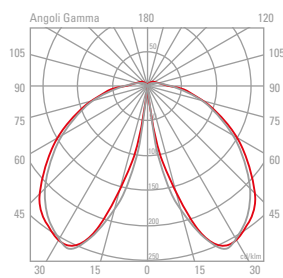

180° — 0°
90° — 270°

Serie I-Dea

Cod. 5536+5531 BL

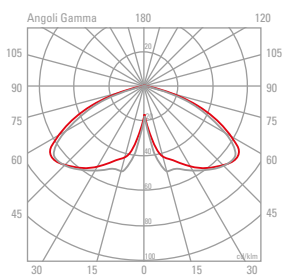

Cod. 5536+5531 AR

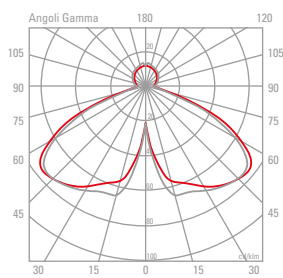

Cod. 5536+5531 OP

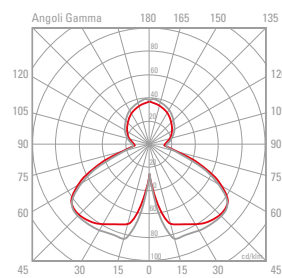

Cod. 5536+5531 VE

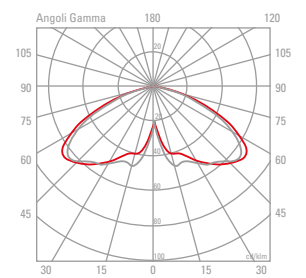

180° — 0°
90° — 270°

Cod. 5536+5534 VE.SM

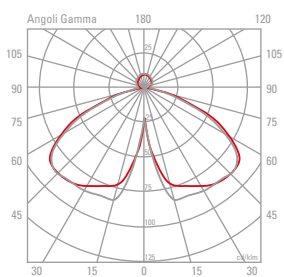

Cod. 5536+5534 AM.BR

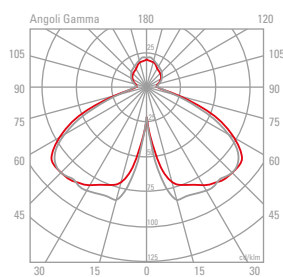

Cod. 5536+5534 BL.ZR

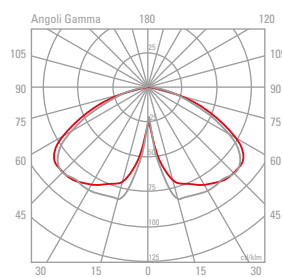

180° — 0°
90° — 270°

Serie Small Midi Maxi Led

Cod. 5608

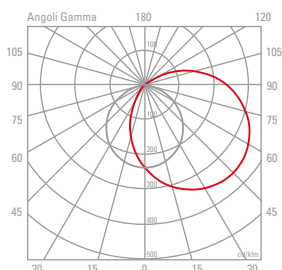

180° — 0°
90° — 270°

Cod. 5621

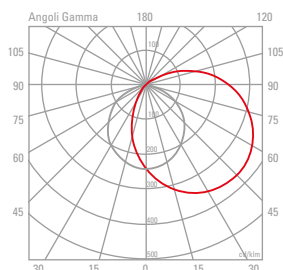

Cod. 5638

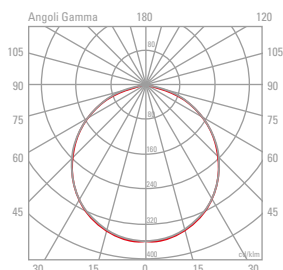

Serie Supermaxi

Cod. 5662

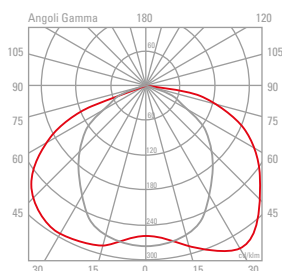

180° — 0°
90° — 270°

Cod. 5667

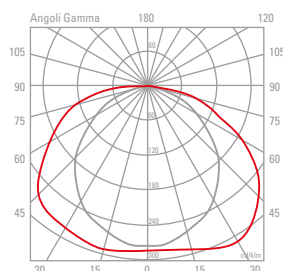

Cod. 5675

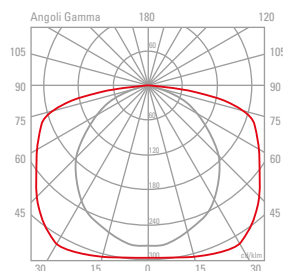

Serie Supermaxi Led

Cod. 5212

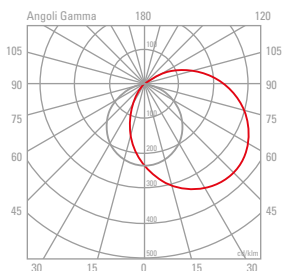

180° — 0°
90° — 270°

Cod. 5213

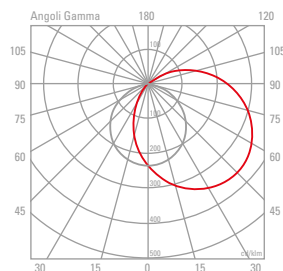

Cod. 5221

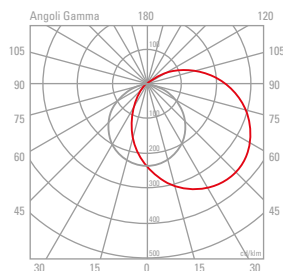

Cod. 5223

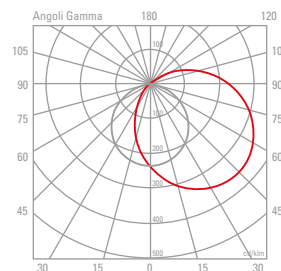

Cod. 5232

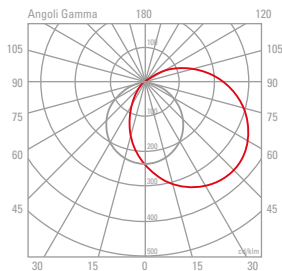

180° — 0°
90° — 270°

Cod. 5233

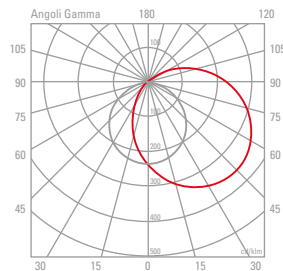

Serie Triangolo Led

Cod. 4224 30°

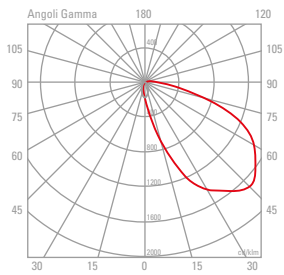

Cod. 4224 38°

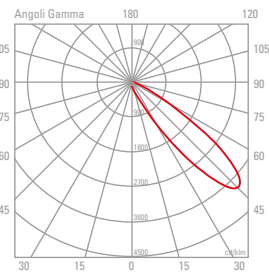

Cod. 4224 90°

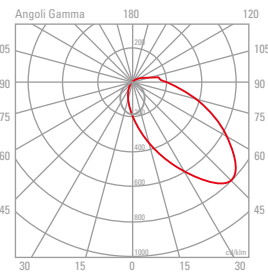

Cod. 4224 120°

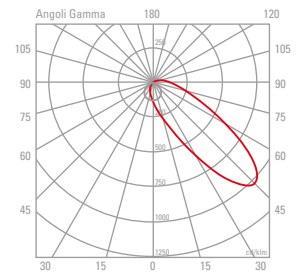

180° — 0°
90° — 270°

Cod. 4220

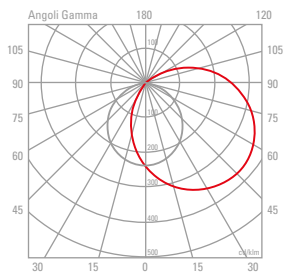

Cod. 4223

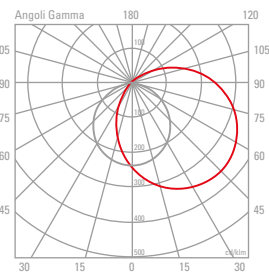

180° — 0°
90° — 270°

Serie Triangolo con griglia | Serie Triangolo with guard

Cod. 4160

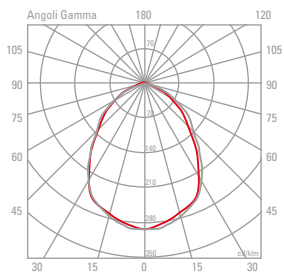

Cod. 4134

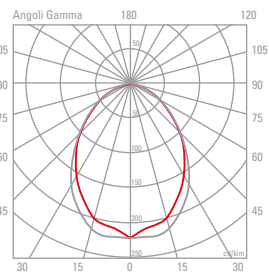

Cod. 4211

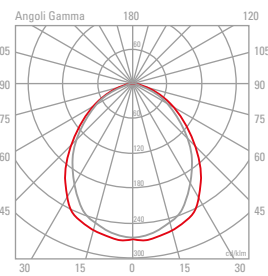

Cod. 4216

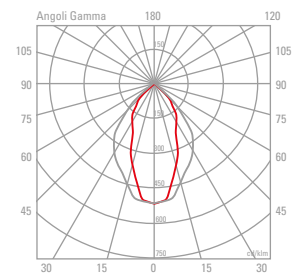

180° — 0°
90° — 270°

Serie Triangolo Fresnel

Cod. 4170

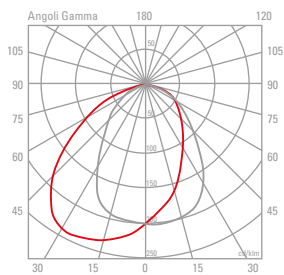

Cod. 4236

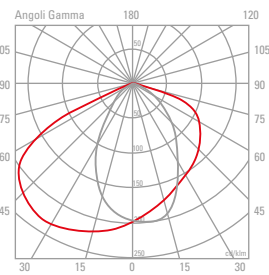

Serie Triangolo Diamond

Cod. 4180

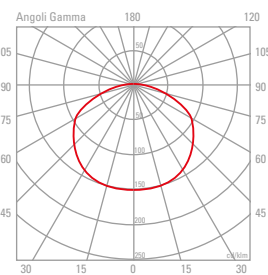

Cod. 4254

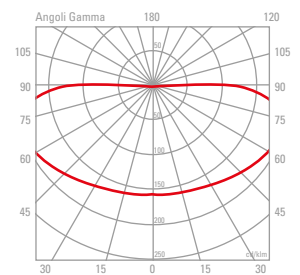

180° — 0°
90° — 270°

180° — 0°
90° — 270°

Serie WASH

Cod. 1301

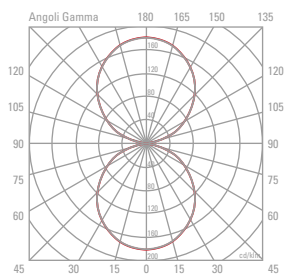

180° — 0°
90° — 270°

Cod. 1305

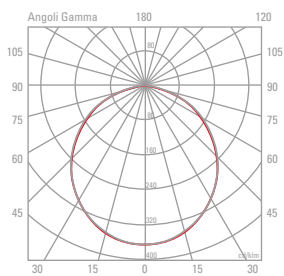

Cod. 1308

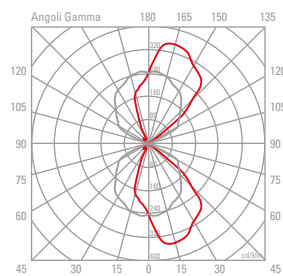

Cod. 1309

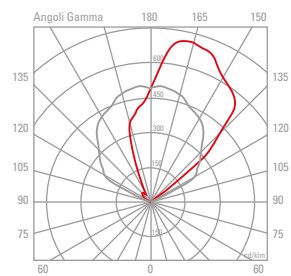

Cod. 1311

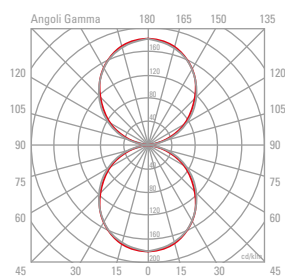

180° — 0°
90° — 270°

Cod. 1312

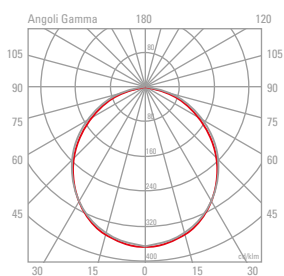

Cod. 1321

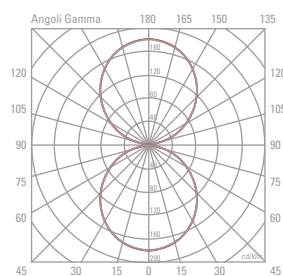

Cod. 1324

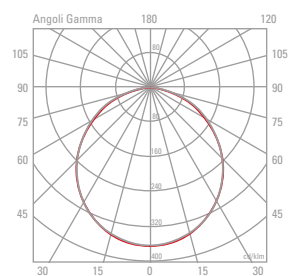

Cod. 1327

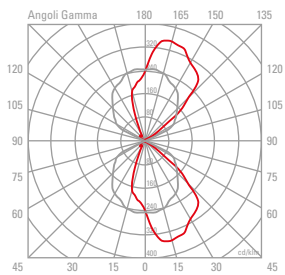

180° — 0°
90° — 270°

Cod. 1328

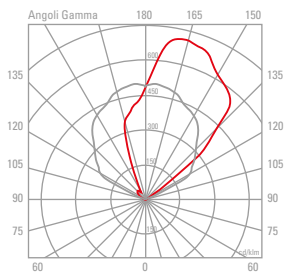

Cod. 1332

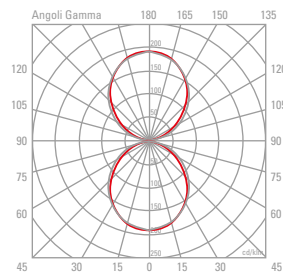

Cod. 1333

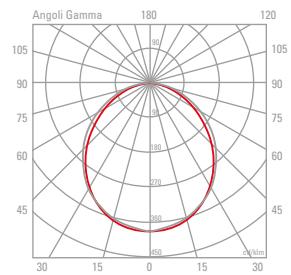

Serie K³ Writer

Cod. 1002

70°

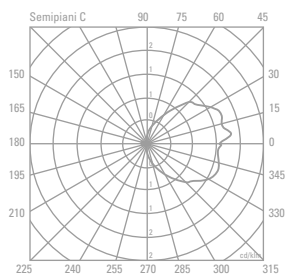

180° — 0°
90° — 270°

Cod. 1004

70°

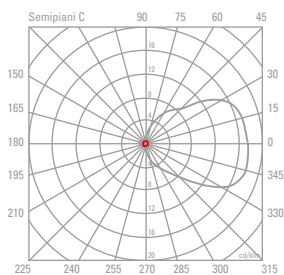

Cod. 1002+1091

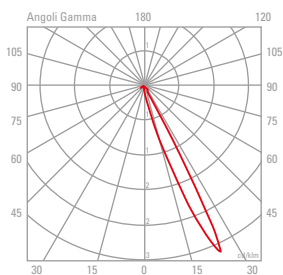

Cod. 1004+1091

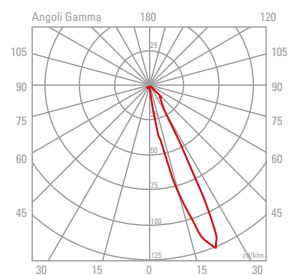

Serie K³ Writer

Cod. 1002+1092

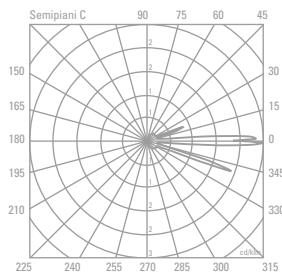

180° — 0°
90° — 270°

Cod. 1004+1092

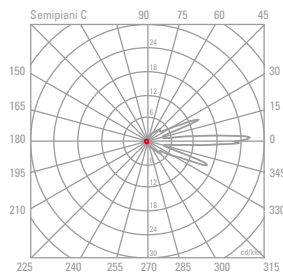

Cod. 1002+1093

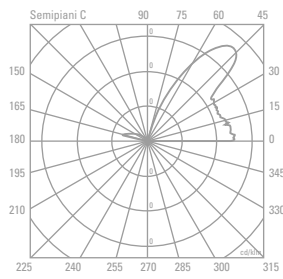

Cod. 1004+1093

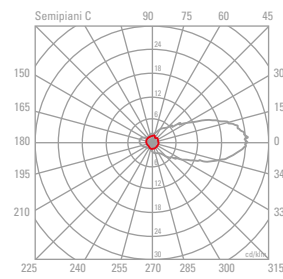

Cod. 1002+1095

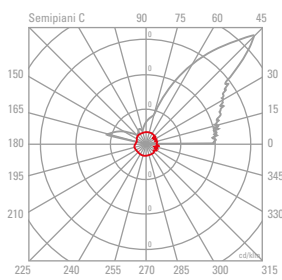

180° — 0°
90° — 270°

Cod. 1004+1095

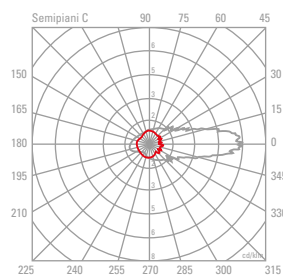

Serie K³ Miniled

Cod. 1040

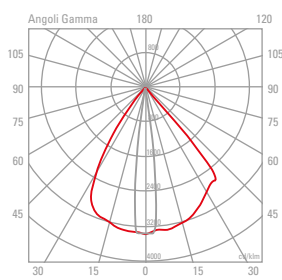

180° — 0°
90° — 270°

Cod. 1041

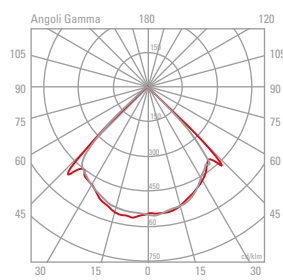

Cod. 1042

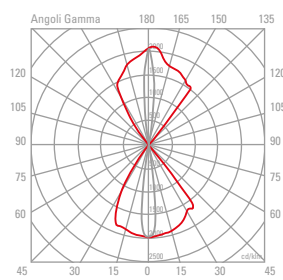

Cod. 1043

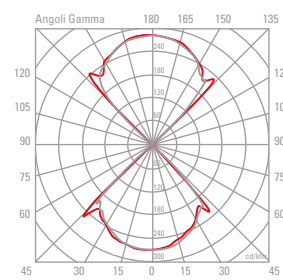

Cod. 1044

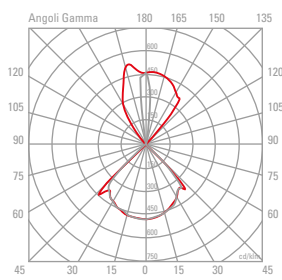

180° — 0°
90° — 270°

Cod. 1045

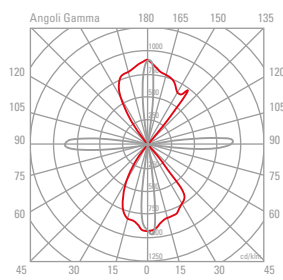

Cod. 1046

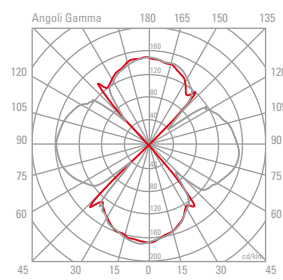

Serie Strike 1

Cod. 4601 10°

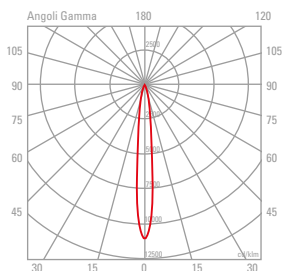

Cod. 4601 24°

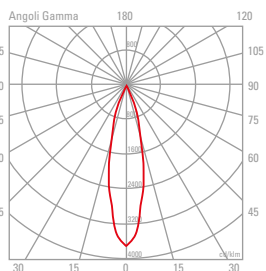

Cod. 4601 38°

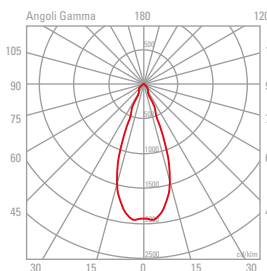

Cod. 4601 60°

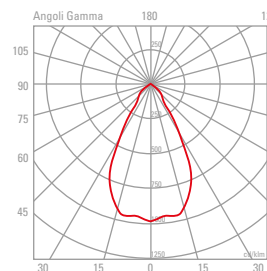

180° — 0°

Cod. 4602 12°

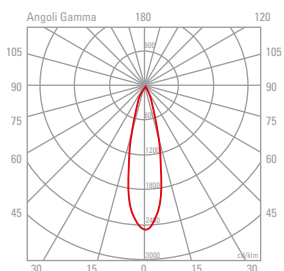

Cod. 4602 40°

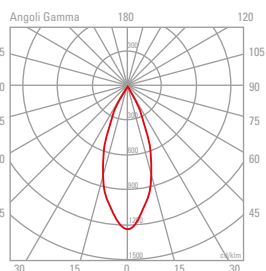

Cod. 4603 50°

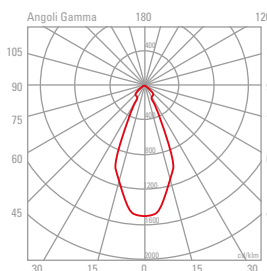

180° — 0°

Cod. 4604 18°

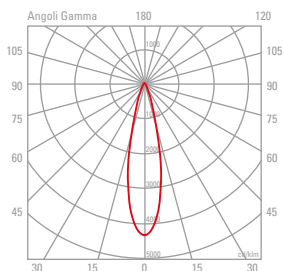

Cod. 4604 38°

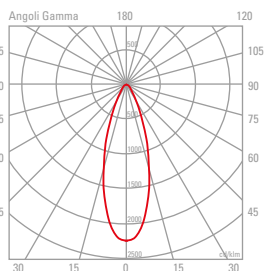

180° — 0°
90° — 270°

Serie Strike 2

Cod. 4613 10°

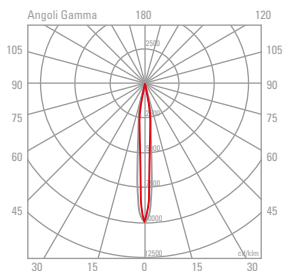

Cod. 4613 40°

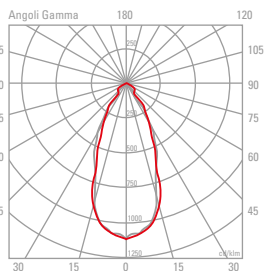

Cod. 4618 10°

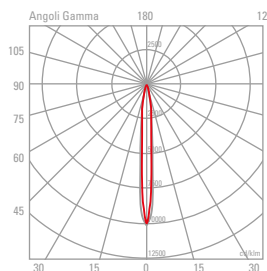

Cod. 4618 40°

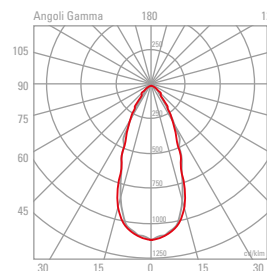

180° — 0°
90° — 270°

Serie Strike 2 Led

Cod. 4614

38°

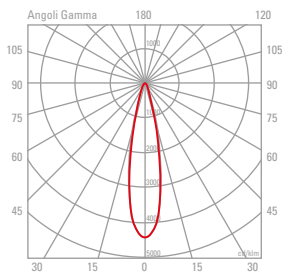

Cod. 4614

90°

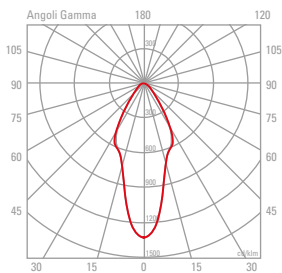

Cod. 4614

120°

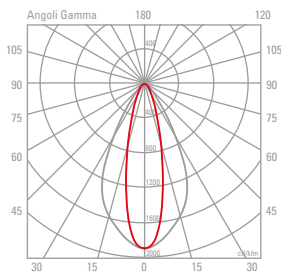

180° — 0°
90° — 270°

Serie Lux Shower

Cod. 1086

30°

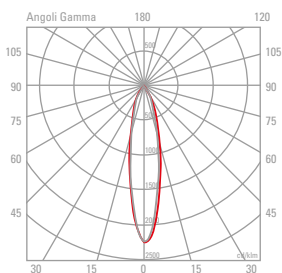

Cod. 1086

60°

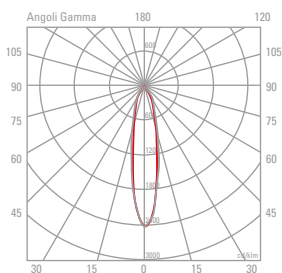

Cod. 1086

90°

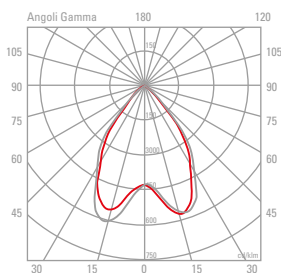

180° — 0°
90° — 270°

Serie Lux Shower Led

Cod. 1087

38°

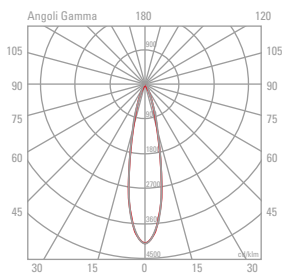

Cod. 1087

90°

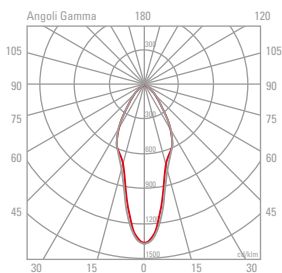

Cod. 1087

120°

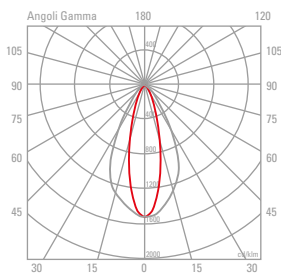

180° — 0°
90° — 270°

Serie Trialo

Cod. 4633

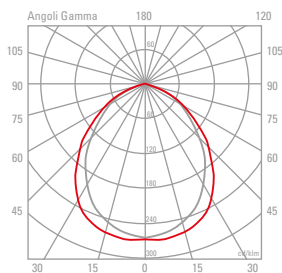

180° — 0°
90° — 270°

Serie Kasko

Cod. 8310

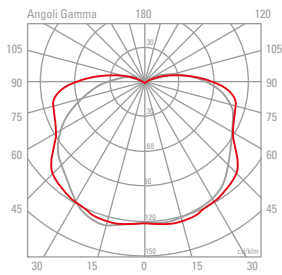

180° — 0°
90° — 270°

Cod. 8610

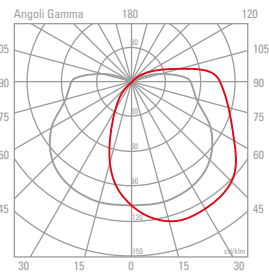

Cod. 8110

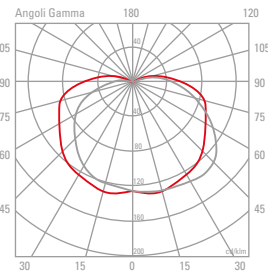

Cod. 8810

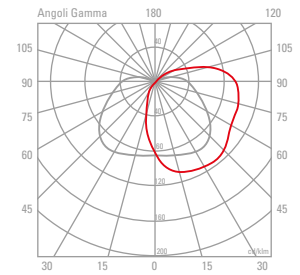

Cod. 8626

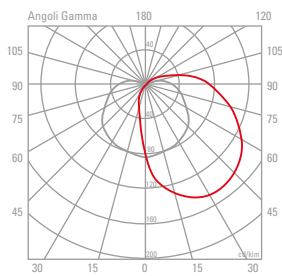

180° — 0°
90° — 270°

Serie Feeling

Cod. 4890

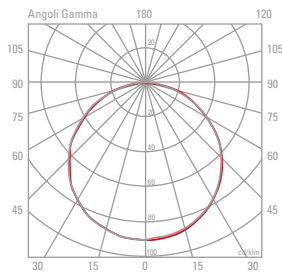

180° — 0°
90° — 270°

Cod. 4821

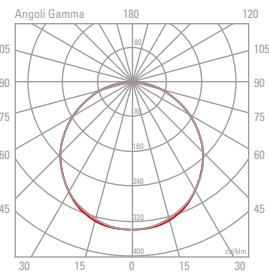

Serie Jack

Cod. 2201+2213

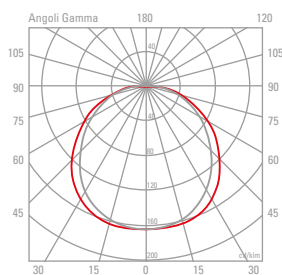

180° — 0°
90° — 270°

Cod. 2201+2214

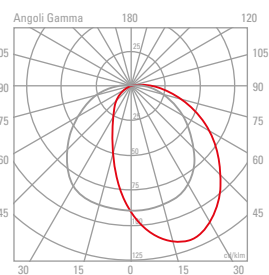

Cod. 2201+2216

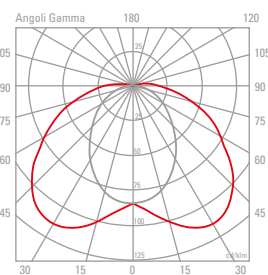

Cod. 2202+2213

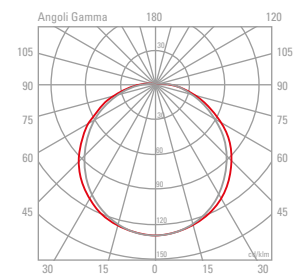

Serie Jack

Cod. 2202+2214

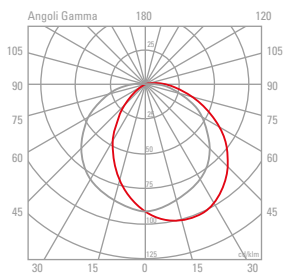

180° — 0°
90° — 270°

Cod. 2202+2216

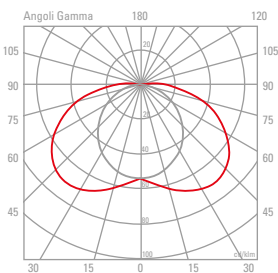

Cod. 2241+2263

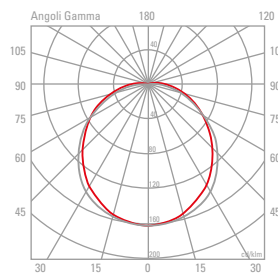

Cod. 2241+2265

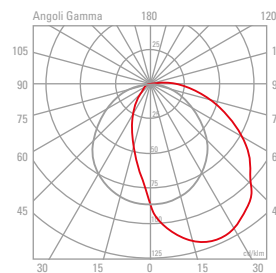

Cod. 2241+2266

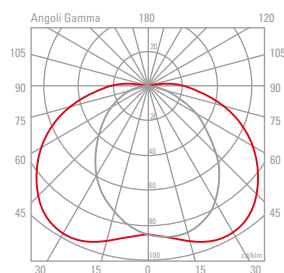

180° — 0°
90° — 270°

Cod. 2242+2263

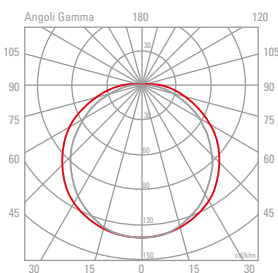

Cod. 2242+2265

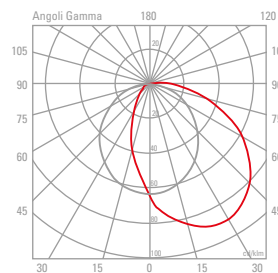

Cod. 2242+2266

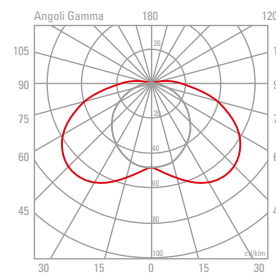

Serie Marina

Cod. 4510

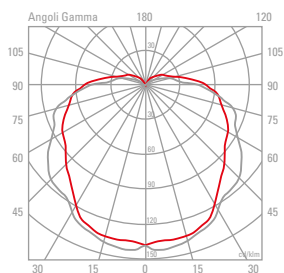

180° — 0°
90° — 270°

Cod. 4720

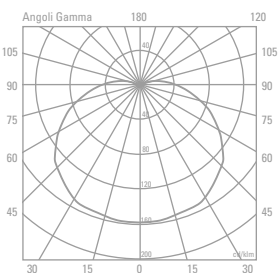

Cod. 4546

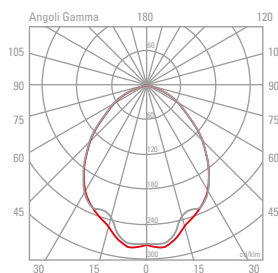

Serie Magnum

Cod. 2395

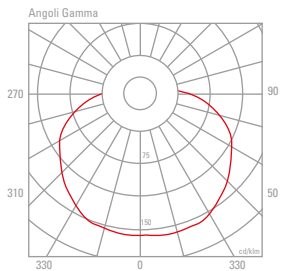

180° — 0°
90° — 270°

Cod. 2397

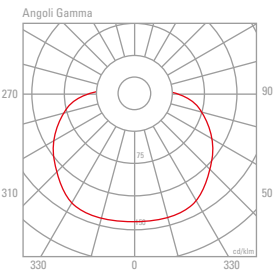



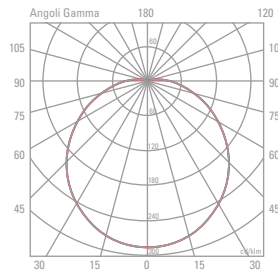









Cod. 2481















**VETRI
GLASSES**

1909	VETRO PER TRIANGOLO PICCOLO FRESNEL / GLASS FOR SMALL TRIANGOLO FRESNEL
1910	VETRO PER TRIANGOLO GRANDE FRESNEL / GLASS FOR LARGE TRIANGOLO FRESNEL
1911	VETRO PER TRIANGOLO PICCOLO DIAMOND / GLASS FOR SMALL TRIANGOLO DIAMOND
1912	VETRO PER TRIANGOLO GRANDE DIAMOND / GLASS FOR LARGE TRIANGOLO DIAMOND
1913	VETRO PER TRIANGOLO PICCOLO LED / GLASS FOR SMALL TRIANGOLO LED
1914	VETRO PER TRIANGOLO GRANDE LED / GLASS FOR LARGE TRIANGOLO LED
1915	VETRO TRASPARENTE PER TRIANGOLO GRANDE LED / CLEAR GLASS FOR LARGE TRIANGOLO LED
1981	VETRO PER KASKO TONDO / GLASS FOR ROUND KASKO
1982	VETRO PER KASKO TONDO GRANDE / GLASS FOR LARGE ROUND KASKO
1983	VETRO PER KASKO OVALE / GLASS FOR OVAL KASKO
1984	COPPA POLICARBONATO PER KASKO TONDO / POLYCARBONATE DIFFUSER FOR ROUND KASKO
1985	COPPA POLICARBONATO PER KASKO TONDO GRANDE / POLYCARBONATE DIFFUSER FOR LARGE ROUND KASKO
1986	COPPA POLICARBONATO PER KASKO OVALE / POLYCARBONATE DIFFUSER FOR OVAL KASKO
1901	VETRO PER KASKO TONDO LED / GLASS FOR LARGE ROUND KASKO LED
1905	VETRO PER DOCKS / GLASS FOR DOCKS
1906	VETRO PER DOCKS LED / GLASS FOR DOCKS LED
1907	COPPA POLICARBONATO PER DOCKS / POLYCARBONATE DIFFUSER FOR DOCKS
1921	VETRO PER JACK TONDA / GLASS FOR ROUND JACK
1922	VETRO PER JACK OVALE / GLASS FOR OVAL JACK
1902	VETRO PER JACK LED TONDA / GLASS FOR ROUND JACK LED
1903	VETRO PER JACK LED OVALE / GLASS FOR OVAL JACK LED
1908	COPPA POLICARBONATO PER JACK / JACK LED TONDA / POLYCARBONATE DIFFUSER FOR ROUND JACK / JACK LED
1968	SFERA ACRILICA PER SUMMERTIME / ACRYLIC DIFFUSER FOR SUMMERTIME
1992	VETRO PER MARINA OVALE PICCOLA / GLASS FOR SMALL OVAL MARINA
1993	VETRO PER MARINA OVALE GRANDE / GLASS FOR LARGE OVAL MARINA
1995	VETRO PER MARINA TONDA / GLASS FOR ROUND MARINA
1998	COPPA POLICARBONATO PER MARINA OVALE / POLYCARBONATE DIFFUSER FOR OVAL MARINA
1999	COPPA POLICARBONATO PER MARINA TONDA / POLYCARBONATE DIFFUSER FOR ROUND MARINA
1997	COPPA POLICARBONATO PER MAGNUM / POLYCARBONATE DIFFUSER FOR MAGNUM









COD.	SERIE	DESCRIZIONE	WATT	ATTACCO	CLASSE ENERGETICA
CODE NO.	RANGE	DESCRIPTION	WATT	LAMPHOLDER	ENERGY CLASS
5636ELNE	SMALL MIDI MAXI	MAXI L=551mm, nero / MAXI length=551mm, black	36 W	2G11	A+, A, B
5636ELSI	SMALL MIDI MAXI	MAXI L=551mm, silver / MAXI length=551mm, silver	36 W	2G11	A+, A, B
5637ELNE	SMALL MIDI MAXI	MAXI con griglia, L=551mm, nero / MAXI with guard, length=551mm, black	36 W	2G11	A+, A, B
5637ELSI	SMALL MIDI MAXI	MAXI con griglia, L=551mm, silver / MAXI with guard, length=551mm, silver	36 W	2G11	A+, A, B
4211ELGR	TRIANGOLO	grande, alluminio, grafite / large, aluminium, graphite	2x18 W	2G11	A+, A, B
4211ELSI	TRIANGOLO	grande, alluminio, silver / large, aluminium, silver	2x18 W	2G11	A+, A, B
4231ELGR	TRIANGOLO	FRESNEL, grande, alluminio, grafite / FRESNEL, large, aluminium, graphite	2x18 W	2G11	A+, A, B
4231ELSI	TRIANGOLO	FRESNEL, grande, alluminio, silver / FRESNEL, large, aluminium, silver	2x18 W	2G11	A+, A, B
4251ELGR	TRIANGOLO	DIAMOND, grande, alluminio, grafite / DIAMOND, large, aluminium, graphite	2x18 W	2G11	A+, A, B
4251ELSI	TRIANGOLO	DIAMOND, grande, alluminio, silver / DIAMOND, large, aluminium, silver	2x18 W	2G11	A+, A, B
8428ELBI	KASKO	tonda grande, bianco / large round, white	2x9 W	2G7	A+, A, B
8428ELGR	KASKO	tonda grande, grafite / large round, graphite	2x9 W	2G7	A+, A, B
8428ELSI	KASKO	tonda grande, silver / large round, silver	2x9 W	2G7	A+, A, B
8426ELBI	 KASKO	tonda grande, bianco / large round, white	26 W	G24q-3	A+, A, B
8426ELGR	 KASKO	tonda grande, grafite / large round, graphite	26 W	G24q-3	A+, A, B
8426ELSI	 KASKO	tonda grande, silver / large round, silver	26 W	G24q-3	A+, A, B
8496ELBI	KASKO	tonda grande, antivandalo, bianco / large round, vandalproof, white	2x9 W	2G7	A+, A, B
8496ELGR	KASKO	tonda grande, antivandalo, grafite / large round, vandalproof, graphite	2x9 W	2G7	A+, A, B
8496ELSI	KASKO	tonda grande, antivandalo, silver / large round, vandalproof, silver	2x9 W	2G7	A+, A, B
8497ELBI	 KASKO	tonda grande, antivandalo, bianco / large round, vandalproof, white	26 W	G24q-3	A+, A, B
8497ELGR	 KASKO	tonda grande, antivandalo, grafite / large round, vandalproof, graphite	26 W	G24q-3	A+, A, B
8497ELSI	 KASKO	tonda grande, antivandalo, silver / large round, vandalproof, silver	26 W	G24q-3	A+, A, B
8328ELBI	KASKO	tonda grande con griglia, bianco / large round with guard, white	2x9 W	2G7	A+, A, B
8328ELGR	KASKO	tonda grande con griglia, grafite / large round with guard, graphite	2x9 W	2G7	A+, A, B
8328ELSI	KASKO	tonda grande con griglia, silver / large round with guard, silver	2x9 W	2G7	A+, A, B
8326ELBI	 KASKO	tonda grande con griglia, bianco / large round with guard, white	26 W	G24q-3	A+, A, B
8326ELGR	 KASKO	tonda grande con griglia, grafite / large round with guard, graphite	26 W	G24q-3	A+, A, B
8326ELSI	 KASKO	tonda grande con griglia, silver / large round with guard, silver	26 W	G24q-3	A+, A, B
8396ELBI	KASKO	tonda grande con griglia, antivandalo, bianco / large round with guard, vandalproof, white	2x9 W	2G7	A+, A, B
8396ELGR	KASKO	tonda grande con griglia, antivandalo, grafite / large round with guard, vandalproof, graphite	2x9 W	2G7	A+, A, B
8396ELSI	KASKO	tonda grande con griglia, antivandalo, silver / large round with guard, vandalproof, silver	2x9 W	2G7	A+, A, B
8397ELBI	 KASKO	tonda grande con griglia, antivandalo, bianco / large round with guard, vandalproof, white	26 W	G24q-3	A+, A, B
8397ELGR	 KASKO	tonda grande con griglia, antivandalo, grafite / large round with guard, vandalproof, graphite	26 W	G24q-3	A+, A, B
8397ELSI	 KASKO	tonda grande con griglia, antivandalo, silver / large round with guard, vandalproof, silver	26 W	G24q-3	A+, A, B
8628ELBI	KASKO	tonda grande con palpebra, bianco / large round with cover, white	2x9 W	2G7	A+, A, B
8628ELGR	KASKO	tonda grande con palpebra, grafite / large round with cover, graphite	2x9 W	2G7	A+, A, B
8628ELSI	KASKO	tonda grande con palpebra, silver / large round with cover, silver	2x9 W	2G7	A+, A, B













COD.	SERIE	DESCRIZIONE	WATT	ATTACCO	CLASSE ENERGETICA
CODE NO.	RANGE	DESCRIPTION	WATT	LAMPHOLDER	ENERGY CLASS
8626ELBI	KASKO	tonda grande con palpebra, bianco / <i>large round with cover, white</i>	26 W	G24q-3	A+, A, B
8626ELGR	KASKO	tonda grande con palpebra, grafite / <i>large round with cover, graphite</i>	26 W	G24q-3	A+, A, B
8626ELSI	KASKO	tonda grande con palpebra, silver / <i>large round with cover, silver</i>	26 W	G24q-3	A+, A, B
8696ELBI	KASKO	tonda grande con palpebra, antivandalo, bianco / <i>large round with cover, vandalproof, white</i>	2x9 W	2G7	A+, A, B
8696ELGR	KASKO	tonda grande con palpebra, antivandalo, grafite / <i>large round with cover, vandalproof, graphite</i>	2x9 W	2G7	A+, A, B
8696ELSI	KASKO	tonda grande con palpebra, antivandalo, silver / <i>large round with cover, vandalproof, silver</i>	2x9 W	2G7	A+, A, B
8697ELBI	KASKO	tonda grande con palpebra, antivandalo, bianco / <i>large round with cover, vandalproof, white</i>	26 W	G24q-3	A+, A, B
8697ELGR	KASKO	tonda grande con palpebra, antivandalo, grafite / <i>large round with cover, vandalproof, graphite</i>	26 W	G24q-3	A+, A, B
8697ELSI	KASKO	tonda grande con palpebra, antivandalo, silver / <i>large round with cover, vandalproof, silver</i>	26 W	G24q-3	A+, A, B
8218ELBI	KASKO	ovale, bianco / <i>oval, white</i>	2x9 W	2G7	A+, A, B
8218ELGR	KASKO	ovale, grafite / <i>oval, graphite</i>	2x9 W	2G7	A+, A, B
8218ELSI	KASKO	ovale, silver / <i>oval, silver</i>	2x9 W	2G7	A+, A, B
8216ELBI	 KASKO	ovale, bianco / <i>oval, white</i>	26 W	G24q-3	A+, A, B
8216ELGR	 KASKO	ovale, grafite / <i>oval, graphite</i>	26 W	G24q-3	A+, A, B
8216ELSI	 KASKO	ovale, silver / <i>oval, silver</i>	26 W	G24q-3	A+, A, B
8298ELBI	KASKO	ovale, antivandalo, bianco / <i>oval, vandalproof, white</i>	2x9 W	2G7	A+, A, B
8298ELGR	KASKO	ovale, antivandalo, grafite / <i>oval, vandalproof, graphite</i>	2x9 W	2G7	A+, A, B
8298ELSI	KASKO	ovale, antivandalo, silver / <i>oval, vandalproof, silver</i>	2x9 W	2G7	A+, A, B
8296ELBI	 KASKO	ovale, antivandalo, bianco / <i>oval, vandalproof, white</i>	26 W	G24q-3	A+, A, B
8296ELGR	 KASKO	ovale, antivandalo, grafite / <i>oval, vandalproof, graphite</i>	26 W	G24q-3	A+, A, B
8296ELSI	 KASKO	ovale, antivandalo, silver / <i>oval, vandalproof, silver</i>	26 W	G24q-3	A+, A, B
8118ELBI	KASKO	ovale con griglia, bianco / <i>oval with guard, white</i>	2x9 W	2G7	A+, A, B
8118ELGR	KASKO	ovale con griglia, grafite / <i>oval with guard, graphite</i>	2x9 W	2G7	A+, A, B
8118ELSI	KASKO	ovale con griglia, silver / <i>oval with guard, silver</i>	2x9 W	2G7	A+, A, B
8116ELBI	 KASKO	ovale con griglia, bianco / <i>oval with guard, white</i>	26 W	G24q-3	A+, A, B
8116ELGR	 KASKO	ovale con griglia, grafite / <i>oval with guard, graphite</i>	26 W	G24q-3	A+, A, B
8116ELSI	 KASKO	ovale con griglia, silver / <i>oval with guard, silver</i>	26 W	G24q-3	A+, A, B
8198ELBI	KASKO	ovale con griglia, antivandalo, bianco / <i>oval with guard, vandalproof, white</i>	2x9 W	2G7	A+, A, B
8198ELGR	KASKO	ovale con griglia, antivandalo, grafite / <i>oval with guard, vandalproof, graphite</i>	2x9 W	2G7	A+, A, B
8198ELSI	KASKO	ovale con griglia, antivandalo, silver / <i>oval with guard, vandalproof, silver</i>	2x9 W	2G7	A+, A, B
8196ELBI	 KASKO	ovale con griglia, antivandalo, bianco / <i>oval with guard, vandalproof, white</i>	26 W	G24q-3	A+, A, B
8196ELGR	 KASKO	ovale con griglia, antivandalo, grafite / <i>oval with guard, vandalproof, graphite</i>	26 W	G24q-3	A+, A, B
8196ELSI	 KASKO	ovale con griglia, antivandalo, silver / <i>oval with guard, vandalproof, silver</i>	26 W	G24q-3	A+, A, B
8818ELBI	KASKO	ovale con palpebra, bianco / <i>oval with cover, white</i>	2x9 W	2G7	A+, A, B
8818ELGR	KASKO	ovale con palpebra, grafite / <i>oval with cover, graphite</i>	2x9 W	2G7	A+, A, B
8818ELSI	KASKO	ovale con palpebra, silver / <i>oval with cover, silver</i>	2x9 W	2G7	A+, A, B
8816ELBI	KASKO	ovale con palpebra, bianco / <i>oval with cover, white</i>	26 W	G24q-3	A+, A, B



COD.	SERIE	DESCRIZIONE	WATT	ATTACCO	CLASSE ENERGETICA
CODE NO.	RANGE	DESCRIPTION	WATT	LAMPHOLDER	ENERGY CLASS
8816ELGR	KASKO	ovale con palpebra, grafite / oval with cover, graphite	26 W	G24q-3	A+, A, B
8816ELSI	KASKO	ovale con palpebra, silver / oval with cover, silver	26 W	G24q-3	A+, A, B
8898ELBI	KASKO	ovale con palpebra, antivandalo, bianco / oval with cover, vandalproof, white	2x9 W	2G7	A+, A, B
8898ELGR	KASKO	ovale con palpebra, antivandalo, grafite / oval with cover, vandalproof, graphite	2x9 W	2G7	A+, A, B
8898ELSI	KASKO	ovale con palpebra, antivandalo, silver / oval with cover, vandalproof, silver	2x9 W	2G7	A+, A, B
8896ELBI	KASKO	ovale con palpebra, antivandalo, bianco / oval with cover, vandalproof, white	26 W	G24q-3	A+, A, B
8896ELGR	KASKO	ovale con palpebra, antivandalo, grafite / oval with cover, vandalproof, graphite	26 W	G24q-3	A+, A, B
8896ELSI	KASKO	ovale con palpebra, antivandalo, silver / oval with cover, vandalproof, silver	26 W	G24q-3	A+, A, B
4883ELGM	FEELING	senza retroilluminazione, antivandalo, grigio met. / without back-light, vandalproof, light grey	2x18 W	2G11	A+, A, B
4883ELGR	FEELING	senza retroilluminazione, antivandalo, grafite / without back-light, vandalproof, graphite	2x18 W	2G11	A+, A, B
4894ELGM.BL	FEELING	con retroilluminazione, antivandalo, grigio met.+blu/with back-light, vandalproof, light grey+blue	2x18 W	2G11	A+, A, B
4894ELGM.VE	FEELING	con retroilluminazione, antivandalo, grigio met.+verde/with back-light, vandalproof, light grey+green	2x18 W	2G11	A+, A, B
4894ELGM.OP	FEELING	con retroilluminazione, antivandalo, grigio met.+opale/with back-light, vandalproof, light grey+opal white	2x18 W	2G11	A+, A, B
4894ELGR.BL	FEELING	con retroilluminazione, antivandalo, grafite+blu/with back-light, vandalproof, graphite+blue	2x18 W	2G11	A+, A, B
4894ELGR.VE	FEELING	con retroilluminazione, antivandalo, grafite+verde/with back-light, vandalproof, graphite+green	2x18 W	2G11	A+, A, B
4894ELGR.OP	FEELING	con retroilluminazione, antivandalo, grafite+opale/with back-light, vandalproof, graphite+opal white	2x18 W	2G11	A+, A, B
2849ELBI	MARINA	PALPEBRA grande, bianco / large PALPEBRA, white	2x9 W	2G7	A+, A, B
2849ELGR	MARINA	PALPEBRA grande, grafite / large PALPEBRA, graphite	2x9 W	2G7	A+, A, B
2846ELBI	MARINA	PALPEBRA grande, bianco / large PALPEBRA, white	26 W	G24q-3	A+, A, B
2846ELGR	MARINA	PALPEBRA grande, grafite / large PALPEBRA, graphite	26 W	G24q-3	A+, A, B
2898ELBI	MARINA	PALPEBRA grande, antivandalo, bianco / large PALPEBRA, vandalproof, white	2x9 W	2G7	A+, A, B
2898ELGR	MARINA	PALPEBRA grande, antivandalo, grafite / large PALPEBRA, vandalproof, graphite	2x9 W	2G7	A+, A, B
2896ELBI	MARINA	PALPEBRA grande, antivandalo, bianco / large PALPEBRA, vandalproof, white	26 W	G24q-3	A+, A, B
2896ELGR	MARINA	PALPEBRA grande, antivandalo, grafite / large PALPEBRA, vandalproof, graphite	26 W	G24q-3	A+, A, B
4549ELBI	MARINA	ovale grande, con griglia, bianco / large oval, with guard, white	2x9 W	2G7	A+, A, B
4549ELGR	MARINA	ovale grande, con griglia, grafite / large oval, with guard, graphite	2x9 W	2G7	A+, A, B
4546ELBI	 MARINA	ovale grande, con griglia, bianco / large oval, with guard, white	26 W	G24q-3	A+, A, B
4546ELGR	 MARINA	ovale grande, con griglia, grafite / large oval, with guard, graphite	26 W	G24q-3	A+, A, B
4598ELBI	MARINA	ovale grande, con griglia, antivandalo, bianco / large oval, with guard, vandalproof, white	2x9 W	2G7	A+, A, B
4598ELGR	MARINA	ovale grande, con griglia, antivandalo, grafite / large oval, with guard, vandalproof, graphite	2x9 W	2G7	A+, A, B
4596ELBI	 MARINA	ovale grande, con griglia, antivandalo, bianco / large oval, with guard, vandalproof, white	26 W	G24q-3	A+, A, B
4596ELGR	 MARINA	ovale grande, con griglia, antivandalo, grafite / large oval, with guard, vandalproof, graphite	26 W	G24q-3	A+, A, B
4589ELBI	MARINA	ovale grande, senza griglia, bianco / large oval, without guard, white	2x9 W	2G7	A+, A, B
4589ELGR	MARINA	ovale grande, senza griglia, grafite / large oval, without guard, graphite	2x9 W	2G7	A+, A, B
4586ELBI	 MARINA	ovale grande, senza griglia, bianco / large oval, without guard, white	26 W	G24q-3	A+, A, B
4586ELGR	 MARINA	ovale grande, senza griglia, grafite / large oval, without guard, graphite	26 W	G24q-3	A+, A, B
4594ELBI	MARINA	ovale grande, senza griglia, antivandalo, bianco / large oval, without guard, vandalproof, white	2x9 W	2G7	A+, A, B



COD.	SERIE	DESCRIZIONE	WATT	ATTACCO	CLASSE ENERGETICA
CODE NO.	RANGE	DESCRIPTION	WATT	LAMPHOLDER	ENERGY CLASS
4594ELGR	MARINA	ovale grande, senza griglia, antivandalo, grafite / large oval, without guard, vandalproof, graphite	2x9 W	2G7	A+, A, B
4593ELBI	 MARINA	ovale grande, senza griglia, antivandalo, bianco / large oval, without guard, vandalproof, white	26 W	G24q-3	A+, A, B
4593ELGR	 MARINA	ovale grande, senza griglia, antivandalo, grafite / large oval, without guard, vandalproof, graphite	26 W	G24q-3	A+, A, B
4749ELBI	MARINA	tonda con griglia, bianco / round with guard, white	2x9 W	2G7	A+, A, B
4749ELGR	MARINA	tonda con griglia, grafite / round with guard, graphite	2x9 W	2G7	A+, A, B
4746ELBI	 MARINA	tonda con griglia, bianco / round with guard, white	26 W	G24q-3	A+, A, B
4746ELGR	 MARINA	tonda con griglia, grafite / round with guard, graphite	26 W	G24q-3	A+, A, B
4798ELBI	MARINA	tonda con griglia, antivandalo, bianco / round with guard, vandalproof, white	2x9 W	2G7	A+, A, B
4798ELGR	MARINA	tonda con griglia, antivandalo, grafite / round with guard, vandalproof, graphite	2x9 W	2G7	A+, A, B
4796ELBI	 MARINA	tonda con griglia, antivandalo, bianco / round with guard, vandalproof, white	26 W	G24q-3	A+, A, B
4796ELGR	 MARINA	tonda con griglia, antivandalo, grafite / round with guard, vandalproof, graphite	26 W	G24q-3	A+, A, B
4789ELBI	MARINA	tonda senza griglia, bianco / round without guard, white	2x9 W	2G7	A+, A, B
4789ELGR	MARINA	tonda senza griglia, grafite / round without guard, graphite	2x9 W	2G7	A+, A, B
4786ELBI	 MARINA	tonda senza griglia, bianco / round without guard, white	26 W	G24q-3	A+, A, B
4786ELGR	 MARINA	tonda senza griglia, grafite / round without guard, graphite	26 W	G24q-3	A+, A, B
4793ELBI	MARINA	tonda senza griglia, antivandalo, bianco / round without guard, vandalproof, white	2x9 W	2G7	A+, A, B
4793ELGR	MARINA	tonda senza griglia, antivandalo, grafite / round without guard, vandalproof, graphite	2x9 W	2G7	A+, A, B
4794ELBI	 MARINA	tonda senza griglia, antivandalo, bianco / round without guard, vandalproof, white	26 W	G24q-3	A+, A, B
4794ELGR	 MARINA	tonda senza griglia, antivandalo, grafite / round without guard, vandalproof, graphite	26 W	G24q-3	A+, A, B
2397ELBI	MAGNUM	con griglia, antivandalo, bianco / with guard, vandalproof, white	2x18 W	2G11	A+, A, B
2397ELGR	MAGNUM	con griglia, antivandalo, grafite / with guard, vandalproof, graphite	2x18 W	2G11	A+, A, B
2497ELBI	MAGNUM	senza griglia, antivandalo, bianco / without guard, vandalproof, white	2x18 W	2G11	A+, A, B
2497ELGR	MAGNUM	senza griglia, antivandalo, grafite / without guard, vandalproof, graphite	2x18 W	2G11	A+, A, B

Indice articoli e Classi Energetiche | Code index and Energy class

COD.	SERIE	PAG.	CLASSE ENERGETICA ENERGY CLASS	COD.	SERIE	PAG.	CLASSE ENERGETICA ENERGY CLASS
CODE	RANGE	PAGE		CODE	RANGE	PAGE	
1001BI	K ³ WRITER	176	A+	1044GM	K ³ MINILED	184	A+
1001GM	K ³ WRITER	176	A+	1044GR	K ³ MINILED	184	A+
1001GR	K ³ WRITER	176	A+	1045BI	K ³ MINILED	184	A+
1002BI	K ³ WRITER	176	A+	1045GM	K ³ MINILED	184	A+
1002GM	K ³ WRITER	176	A+	1045GR	K ³ MINILED	184	A+
1002GR	K ³ WRITER	176	A+	1046BI	K ³ MINILED	184	A+
1004BI	K ³ WRITER	176	A+	1046GM	K ³ MINILED	184	A+
1004GM	K ³ WRITER	176	A+	1046GR	K ³ MINILED	184	A+
1004GR	K ³ WRITER	176	A+	1050IN	K ³ MINILED	186	A+
1006BI	K ³ WRITER	176	A+	1051IN	K ³ MINILED	186	A+
1006GM	K ³ WRITER	176	A+	1052IN	K ³ MINILED	186	A+
1006GR	K ³ WRITER	176	A+	1053IN	K ³ MINILED	186	A+
1007BI	K ³ WRITER	176	A+	1054IN	K ³ MINILED	186	A+
1007GM	K ³ WRITER	176	A+	1055IN	K ³ MINILED	186	A+
1007GR	K ³ WRITER	176	A+	1056IN	K ³ MINILED	186	A+
1008BI	K ³ WRITER	176	A+	1085BI	LUX SHOWER	239	A+
1008GM	K ³ WRITER	176	A+	1085GM	LUX SHOWER	239	A+
1008GR	K ³ WRITER	176	A+	1085GR	LUX SHOWER	239	A+
1011IN	K ³ WRITER	177	A+	1086BI	LUX SHOWER	239	A+
1012IN	K ³ WRITER	177	A+	1086GM	LUX SHOWER	239	A+
1014IN	K ³ WRITER	177	A+	1086GR	LUX SHOWER	239	A+
1016IN	K ³ WRITER	177	A+	1087BI	LUX SHOWER	239	A+
1017IN	K ³ WRITER	177	A+	1087GM	LUX SHOWER	239	A+
1018IN	K ³ WRITER	177	A+	1087GR	LUX SHOWER	239	A+
1020BI	K ³ WRITER	176	A+	1090	K ³ MINILED	187	
1020GM	K ³ WRITER	176	A+	1091	K ³ WRITER	178	
1020GR	K ³ WRITER	176	A+	1092	K ³ WRITER	178	
1021BI	K ³ WRITER	176	A+	1093	K ³ WRITER	178	
1021GM	K ³ WRITER	176	A+	1095	K ³ WRITER	178	
1021GR	K ³ WRITER	176	A+	1096AR	K ³ WRITER	179/195	
1022BI	K ³ WRITER	176	A+	1096BL	K ³ WRITER	179/195	
1022GM	K ³ WRITER	176	A+	1096RO	K ³ WRITER	179/195	
1022GR	K ³ WRITER	176	A+	1096VE	K ³ WRITER	179/195	
1031IN	K ³ WRITER	177	A+	1100BI	K ³ POWER	192	A+
1032IN	K ³ WRITER	177	A+	1100GM	K ³ POWER	192	A+
1033IN	K ³ WRITER	177	A+	1100GR	K ³ POWER	192	A+
1040BI	K ³ MINILED	184	A+	1101BI	K ³ POWER	192	A+
1040GM	K ³ MINILED	184	A+	1101GM	K ³ POWER	192	A+
1040GR	K ³ MINILED	184	A+	1101GR	K ³ POWER	192	A+
1041BI	K ³ MINILED	184	A+	1102BI	K ³ POWER	192	A++
1041GM	K ³ MINILED	184	A+	1102GM	K ³ POWER	192	A++
1041GR	K ³ MINILED	184	A+	1102GR	K ³ POWER	192	A++
1042BI	K ³ MINILED	184	A+	1103BI	K ³ POWER	192	A+
1042GM	K ³ MINILED	184	A+	1103GM	K ³ POWER	192	A+
1042GR	K ³ MINILED	184	A+	1103GR	K ³ POWER	192	A+
1043BI	K ³ MINILED	184	A+	1104BI	K ³ POWER	192	A+
1043GM	K ³ MINILED	184	A+	1104GM	K ³ POWER	192	A+
1043GR	K ³ MINILED	184	A+	1104GR	K ³ POWER	192	A+
1044BI	K ³ MINILED	184	A+	1105BI	K ³ POWER	192	A++

COD. CODE	SERIE RANGE	PAG. PAGE	CLASSE ENERGETICA ENERGY CLASS
1105GM	K ³ POWER	192	A++
1105GR	K ³ POWER	192	A++
1106BI	K ³ POWER	192	A++, A+, A, B, C, D, E
1106GM	K ³ POWER	192	A++, A+, A, B, C, D, E
1106GR	K ³ POWER	192	A++, A+, A, B, C, D, E
1107BI	K ³ POWER	192	A+
1107GM	K ³ POWER	192	A+
1107GR	K ³ POWER	192	A+
1108BI	K ³ POWER	192	A+
1108GM	K ³ POWER	192	A+
1108GR	K ³ POWER	192	A+
1109BI	K ³ POWER	192	A++
1109GM	K ³ POWER	192	A++
1109GR	K ³ POWER	192	A++
1110IN	K ³ POWER	193	A+
1111IN	K ³ POWER	193	A+
1112IN	K ³ POWER	193	A++
1113IN	K ³ POWER	193	A+
1114IN	K ³ POWER	193	A+
1115IN	K ³ POWER	193	A++
1116IN	K ³ POWER	193	A++, A+, A, B, C, D, E
1117IN	K ³ POWER	193	A+
1118IN	K ³ POWER	193	A+
1119IN	K ³ POWER	193	A++
1120BI	K ³ POWER	192	A+
1120GM	K ³ POWER	192	A+
1120GR	K ³ POWER	192	A+
1121BI	K ³ POWER	192	A+
1121GM	K ³ POWER	192	A+
1121GR	K ³ POWER	192	A+
1122BI	K ³ POWER	192	A++
1122GM	K ³ POWER	192	A++
1122GR	K ³ POWER	192	A++
1123BI	K ³ POWER	192	A++, A+, A, B, C, D, E
1123GM	K ³ POWER	192	A++, A+, A, B, C, D, E
1123GR	K ³ POWER	192	A++, A+, A, B, C, D, E
1125BI	K ³ POWER	192	A+
1125GM	K ³ POWER	192	A+
1125GR	K ³ POWER	192	A+
1126BI	K ³ POWER	192	A+
1126GM	K ³ POWER	192	A+
1126GR	K ³ POWER	192	A+
1128BI	K ³ POWER	192	A++, A+, A, B, C, D, E
1128GM	K ³ POWER	192	A++, A+, A, B, C, D, E
1128GR	K ³ POWER	192	A++, A+, A, B, C, D, E
1130IN	K ³ POWER	193	A+
1131IN	K ³ POWER	193	A+
1132IN	K ³ POWER	193	A++
1133IN	K ³ POWER	193	A++, A+, A, B, C, D, E

COD. CODE	SERIE RANGE	PAG. PAGE	CLASSE ENERGETICA ENERGY CLASS
1135IN	K ³ POWER	193	A+
1136IN	K ³ POWER	193	A+
1138IN	K ³ POWER	193	A++, A+, A, B, C, D, E
1180	RGB LED	67/250	
1184BI	RGB LED	251	A+
1184GM	RGB LED	251	A+
1184GR	RGB LED	251	A+
1188SI	RGB LED	251	A+
1191	K ³ POWER	195	
1192	K ³ POWER	195	
1193	K ³ POWER	195	
1194	K ³ POWER	195	
1201GM	CORINTHIA	204	A+
1201GR	CORINTHIA	204	A+
1202GM	CORINTHIA	204	A+
1202GR	CORINTHIA	204	A+
1206GM	CORINTHIA	205	A+
1206GR	CORINTHIA	205	A+
1207GM	CORINTHIA	205	A+
1207GR	CORINTHIA	205	A+
1208GM	CORINTHIA	205	A+
1208GR	CORINTHIA	205	A+
1209GM	CORINTHIA	205	A++, A+, A, C, D
1209GR	CORINTHIA	205	A++, A+, A, C, D
1211GM	CORINTHIA	205	A+
1211GR	CORINTHIA	205	A+
1212GM	CORINTHIA	205	A+
1212GR	CORINTHIA	205	A+
1213GM	CORINTHIA	205	A+
1213GR	CORINTHIA	205	A+
1214GM	CORINTHIA	205	A++, A+, A, C, D
1214GR	CORINTHIA	205	A++, A+, A, C, D
1301BI	WASH	166	A++
1301GM	WASH	166	A++
1301GR	WASH	166	A++
1302BI	WASH	166	A++, A+, A, B, C, D, E
1302GM	WASH	166	A++, A+, A, B, C, D, E
1302GR	WASH	166	A++, A+, A, B, C, D, E
1305BI	WASH	166	A++
1305GM	WASH	166	A++
1305GR	WASH	166	A++
1306BI	WASH	166	A++, A+, A, B, C, D, E
1306GM	WASH	166	A++, A+, A, B, C, D, E
1306GR	WASH	166	A++, A+, A, B, C, D, E
1308BI	WASH	166	A++
1308GM	WASH	166	A++
1308GR	WASH	166	A++
1309BI	WASH	166	A++
1309GM	WASH	166	A++

Indice articoli e Classi Energetiche | Code index and Energy class

COD. CODE	SERIE RANGE	PAG. PAGE	CLASSE ENERGETICA ENERGY CLASS	COD. CODE	SERIE RANGE	PAG. PAGE	CLASSE ENERGETICA ENERGY CLASS
1309GR	WASH	166	A++	1443	PASSUM	66	A+
1311BI	WASH	166	A++	1444	PASSUM	66	A++, A+, A, B, C, D, E
1311GM	WASH	166	A++	1470GM	LUX SHOWER INSIDE	244	A+
1311GR	WASH	166	A++	1472GM	LUX SHOWER INSIDE	244	A++
1312BI	WASH	166	A++	1473GM	LUX SHOWER INSIDE	244	A++, A+, A, C, D
1312GM	WASH	166	A++	1474GM	LUX SHOWER INSIDE	245	A++
1312GR	WASH	166	A++	1476GM	LUX SHOWER INSIDE	245	A++
1321BI	WASH	167	A++	1477GM	LUX SHOWER INSIDE	245	A+
1321GM	WASH	167	A++	1478GM	LUX SHOWER INSIDE	245	A++, A+, A, B, C, D, E
1321GR	WASH	167	A++	1479GM	LUX SHOWER INSIDE	244	A++
1322BI	WASH	167	A++, A+, A, B, C, D, E	1481	PASSUM	70	A++
1322GM	WASH	167	A++, A+, A, B, C, D, E	1482	PASSUM	67/251	A+
1322GR	WASH	167	A++, A+, A, B, C, D, E	1484	PASSUM	70	A+
1324BI	WASH	167	A++	1485	PASSUM	71	A++
1324GM	WASH	167	A++	1487	PASSUM	72	A++
1324GR	WASH	167	A++	1488	PASSUM	75	A++
1325BI	WASH	167	A++, A+, A, B, C, D, E	1491	PASSUM	60	A++
1325GM	WASH	167	A++, A+, A, B, C, D, E	1494	PASSUM	60	A+
1325GR	WASH	167	A++, A+, A, B, C, D, E	1495	PASSUM	61	A++
1327BI	WASH	167	A++	1496	PASSUM	61	A++, A+, A, C, D
1327GM	WASH	167	A++	1497	PASSUM	63	A++
1327GR	WASH	167	A++	1498	PASSUM	63	A++, A+, A, C, D
1328BI	WASH	167	A++	1511GM	PASSUM	60	
1328GM	WASH	167	A++	1512IN	PASSUM	60	
1328GR	WASH	167	A++	1513IN	PASSUM	60	
1332BI	WASH	167	A++	1515GM	PASSUM	70	
1332GM	WASH	167	A++	1516GM	PASSUM	70	
1332GR	WASH	167	A++	1517GM	PASSUM	70	
1333BI	WASH	167	A++	1519GM	PASSUM	70	
1333GM	WASH	167	A++	1521GM	PASSUM	61/62	
1333GR	WASH	167	A++	1522IN	PASSUM	61/62	
1401	PASSUM	62	A++	1523IN	PASSUM	61/62	
1411	PASSUM	60/70		1525GM	PASSUM	71	
1412	PASSUM	60	A++	1526GM	PASSUM	71	
1413	PASSUM	60	A+	1527GM	PASSUM	71	
1415	PASSUM	70	A++	1529GM	PASSUM	71	
1416	PASSUM	70	A+	1531GM	PASSUM	63	
1421	PASSUM	61/71		1532IN	PASSUM	63	
1422	PASSUM	61	A++	1533IN	PASSUM	63	
1423	PASSUM	62		1535GM	PASSUM	72	
1424	PASSUM	61	A++, A+, A, C, D	1536GM	PASSUM	72	
1427	PASSUM	71	A++	1537GM	PASSUM	72	
1431	PASSUM	63/72/75		1539GM	PASSUM	72	
1432	PASSUM	63	A++	1541GM	PASSUM	66	
1434	PASSUM	63	A++, A+, A, C, D	1542IN	PASSUM	66	
1436	PASSUM	72	A++	1591IN	PASSUM	70	
1438	PASSUM	75	A++	1593IN	PASSUM	70	
1441	PASSUM	66/67		1594IN	PASSUM	70	
1442	PASSUM	66	A++				

COD. CODE	SERIE RANGE	PAG. PAGE	CLASSE ENERGETICA ENERGY CLASS
1901	RICAMBI / SPARE-PARTS	334	
1902	RICAMBI / SPARE-PARTS	334	
1903	RICAMBI / SPARE-PARTS	334	
1905	RICAMBI / SPARE-PARTS	334	
1906	RICAMBI / SPARE-PARTS	334	
1907	RICAMBI / SPARE-PARTS	334	
1908	RICAMBI / SPARE-PARTS	334	
1909	RICAMBI / SPARE-PARTS	334	
1910	RICAMBI / SPARE-PARTS	334	
1911	RICAMBI / SPARE-PARTS	334	
1912	RICAMBI / SPARE-PARTS	334	
1913	RICAMBI / SPARE-PARTS	334	
1914	RICAMBI / SPARE-PARTS	334	
1915	RICAMBI / SPARE-PARTS	334	
1921	RICAMBI / SPARE-PARTS	334	
1922	RICAMBI / SPARE-PARTS	334	
1941	STANDING	81/218	
1942	STANDING	81/218	
1952	PASSUM	77/245	
1954	PASSUM	77/245	
1955	PASSUM	77/245	
1968	RICAMBI / SPARE-PARTS	334	
1981	RICAMBI / SPARE-PARTS	334	
1982	RICAMBI / SPARE-PARTS	334	
1983	RICAMBI / SPARE-PARTS	334	
1984	RICAMBI / SPARE-PARTS	334	
1985	RICAMBI / SPARE-PARTS	334	

COD. CODE	SERIE RANGE	PAG. PAGE	CLASSE ENERGETICA ENERGY CLASS
1986	RICAMBI / SPARE-PARTS	334	
1992	RICAMBI / SPARE-PARTS	334	
1993	RICAMBI / SPARE-PARTS	334	
1995	RICAMBI / SPARE-PARTS	334	
1997	RICAMBI / SPARE-PARTS	334	
1998	RICAMBI / SPARE-PARTS	334	
1999	RICAMBI / SPARE-PARTS	334	
2101NE	JACK LED	296	A+
2105NE	JACK LED	296/318	A+
2143NE	JACK LED	297	A+
2146NE	JACK LED	297/318	A+
2191NE	JACK LED	296	A+
2195NE	JACK LED	296/318	A+
2201NE	JACK	292	A++, A+, A, B, C, D, E
2202NE	JACK	292	A+, A, B
2213BI	JACK	292	
2213NE	JACK	292	
2213SI	JACK	292	
2214NE	JACK	292	
2214SI	JACK	292	
2215NE	JACK	292	
2215SI	JACK	292	
2216NE	JACK	292	
2216SI	JACK	292	
2217NE	JACK	292	
2217SI	JACK	292	
2241NE	JACK	293	A++, A+, A, B, C, D, E
2242NE	JACK	293	A+, A, B
2263BI	JACK	293	
2263NE	JACK	293	
2263SI	JACK	293	
2264NE	JACK	293	
2264SI	JACK	293	
2265NE	JACK	293	
2265SI	JACK	293	
2266NE	JACK	293	
2266SI	JACK	293	
2267NE	JACK	293	
2267SI	JACK	293	
2291NE	JACK	292	A++, A+, A, B, C, D, E
2292NE	JACK	292	A+, A, B
2380BI	MAGNUM	309	A++

Indice articoli e Classi Energetiche | Code index and Energy class

COD. CODE	SERIE RANGE	PAG. PAGE	CLASSE ENERGETICA ENERGY CLASS	COD. CODE	SERIE RANGE	PAG. PAGE	CLASSE ENERGETICA ENERGY CLASS
2380GR	MAGNUM	309	A++	3502GR	I-LUX	97/102/110/117	
2386BI	MAGNUM	309	A++	3503GM	CANTHARELLUS	97	
2386GR	MAGNUM	309	A++	3503GR	I-LUX	97/102	
2395BI	MAGNUM	309	A++, A+, A, B, C, D, E	3511IN	I-LUX	103/110	
2395GR	MAGNUM	309	A++, A+, A, B, C, D, E	3512IN	I-LUX	103/110	
2397BI	MAGNUM	309	A+, A, B	3686GR	KASKO	277	
2397GR	MAGNUM	309	A+, A, B	3686SI	KASKO	277	
2399BI	MAGNUM	309	A+, A, B	3701NE	SMALL MIDI MAXI & SUPERMAXI	138	
2399GR	MAGNUM	309	A+, A, B	3701SI	SMALL MIDI MAXI & SUPERMAXI	138	
2481BI	MAGNUM	309	A++	3702NE	SMALL MIDI MAXI & SUPERMAXI	138	
2481GR	MAGNUM	309	A++	3702SI	SMALL MIDI MAXI & SUPERMAXI	138	
2488BI	MAGNUM	309/318	A++	3721GM	COMPATTA	87	
2488GR	MAGNUM	309/318	A++	3721GR	COMPATTA	87	
2495BI	MAGNUM	309	A++, A+, A, B, C, D, E	3722GM	COMPATTA	87	
2495GR	MAGNUM	309	A++, A+, A, B, C, D, E	3722GR	COMPATTA	87	
2497BI	MAGNUM	309	A+, A, B	3723GM	COMPATTA	87	
2497GR	MAGNUM	309	A+, A, B	3723GR	COMPATTA	87	
2499BI	MAGNUM	309	A+, A, B	4051SI	STRIKE 1	229	
2499GR	MAGNUM	309	A+, A, B	4053AR	STRIKE 1	229	
2806BI	MARINA	302	A++, A+, A, B, C, D, E	4053BL	STRIKE 1	229	
2806GR	MARINA	302	A++, A+, A, B, C, D, E	4053GI	STRIKE 1	229	
2813BI	MARINA	302	A+, A, B	4053RO	STRIKE 1	229	
2813GR	MARINA	302	A+, A, B	4053VE	STRIKE 1	229	
2825BI	MARINA	302	A++, A+, A, B, C, D, E	4055	STRIKE 1	229	
2825GR	MARINA	302	A++, A+, A, B, C, D, E	4057	STRIKE 1	229	
2846BI	MARINA	302	A+, A, B	4059	STRIKE 1	229	
2846GR	MARINA	302	A+, A, B	4160GR	TRIANGOLO	148	A++, A+, A, B, C, D, E
2849BI	MARINA	302	A+, A, B	4160SI	TRIANGOLO	148	A++, A+, A, B, C, D, E
2849GR	MARINA	302	A+, A, B	4163GR	TRIANGOLO	148	A+, A, B
2895BI	MARINA	302	A++, A+, A, B, C, D, E	4163SI	TRIANGOLO	148	A+, A, B
2895GR	MARINA	302	A++, A+, A, B, C, D, E	4170GR	TRIANGOLO	149	A++, A+, A, B, C, D, E
2896BI	MARINA	302	A+, A, B	4170SI	TRIANGOLO	149	A++, A+, A, B, C, D, E
2896GR	MARINA	302	A+, A, B	4173GR	TRIANGOLO	149	A+, A, B
2898BI	MARINA	302	A+, A, B	4173SI	TRIANGOLO	149	A+, A, B
2898GR	MARINA	302	A+, A, B	4180GR	TRIANGOLO	150	A++, A+, A, B, C, D, E
2933	SUMMERTIME	313	A++, A+, A, B, C, D, E	4180SI	TRIANGOLO	150	A++, A+, A, B, C, D, E
3201NE	JACK	292		4183GR	TRIANGOLO	150	A+, A, B
3202NE	JACK	293		4183SI	TRIANGOLO	150	A+, A, B
3322GR	TRIANGOLO	156		4210GR	TRIANGOLO	148	A++, A+, A, B, C, D, E
3341GR	TRIANGOLO	151		4210SI	TRIANGOLO	148	A++, A+, A, B, C, D, E
3341SI	TRIANGOLO	151		4211GR	TRIANGOLO	148	A+, A, B
3344GR	TRIANGOLO	151		4211SI	TRIANGOLO	148	A+, A, B
3344SI	TRIANGOLO	151		4214GR	TRIANGOLO	148	A+, A, B
3351GR	TRIANGOLO CITY	156		4214SI	TRIANGOLO	148	A+, A, B
3353GR	TRIANGOLO CITY	157		4215GR	TRIANGOLO	148	A+
3396GR	TRIANGOLO CITY	156					
3501GM	CANTHARELLUS	97					
3501GR	I-LUX	97/102/110/117					
3502GM	CANTHARELLUS	97					

COD.	SERIE	PAG.	CLASSE
CODE	RANGE	PAGE	ENERGETICA ENERGY CLASS
4215SI	TRIANGOLO	148	A+
4216GR	TRIANGOLO	148	A+
4216SI	TRIANGOLO	148	A+
4217GR	TRIANGOLO	148	A+
4217SI	TRIANGOLO	148	A+
4218GR	TRIANGOLO	148	A+
4218SI	TRIANGOLO	148	A+
4220GR	TRIANGOLO	147	A+
4220SI	TRIANGOLO	147	A+
4223GR	TRIANGOLO	147	A+
4223SI	TRIANGOLO	147	A+
4224GR	TRIANGOLO	147	A+
4224SI	TRIANGOLO	147	A+
4229GR	TRIANGOLO	147	A+
4229SI	TRIANGOLO	147	A+
4230GR	TRIANGOLO	149	A++, A+, A, B, C, D, E
4230SI	TRIANGOLO	149	A++, A+, A, B, C, D, E
4231GR	TRIANGOLO	149	A+, A, B
4231SI	TRIANGOLO	149	A+, A, B
4234GR	TRIANGOLO	149	A+, A, B
4234SI	TRIANGOLO	149	A+, A, B
4235GR	TRIANGOLO	149	A+
4235SI	TRIANGOLO	149	A+
4236GR	TRIANGOLO	149	A+
4236SI	TRIANGOLO	149	A+
4237GR	TRIANGOLO	149	A+
4237SI	TRIANGOLO	149	A+
4238GR	TRIANGOLO	149	A+
4238SI	TRIANGOLO	149	A+
4250GR	TRIANGOLO	150	A++, A+, A, B, C, D, E
4250SI	TRIANGOLO	150	A++, A+, A, B, C, D, E
4251GR	TRIANGOLO	150	A+, A, B
4251SI	TRIANGOLO	150	A+, A, B
4254GR	TRIANGOLO	150	A+, A, B
4254SI	TRIANGOLO	150	A+, A, B
4255GR	TRIANGOLO	150	A+
4255SI	TRIANGOLO	150	A+
4256GR	TRIANGOLO	150	A+
4256SI	TRIANGOLO	150	A+
4257GR	TRIANGOLO	150	A+
4257SI	TRIANGOLO	150	A+
4258GR	TRIANGOLO	150	A+
4258SI	TRIANGOLO	150	A+
4301NE	JACK LED	296/318	A+
4302NE	JACK LED	296/318	A+
4400BI	DOCKS	260	A+, A, B
4400GM	DOCKS	260	A+, A, B
4400GR	DOCKS	260	A+, A, B
4402BI	DOCKS	260	A+, A, B

COD.	SERIE	PAG.	CLASSE
CODE	RANGE	PAGE	ENERGETICA ENERGY CLASS
4402GM	DOCKS	260	A+, A, B
4402GR	DOCKS	260	A+, A, B
4403BI	DOCKS	260	A+, A, B
4403GM	DOCKS	260	A+, A, B
4403GR	DOCKS	260	A+, A, B
4404IN	DOCKS	262	A+, A, B
4405IN	DOCKS	262	A+, A, B
4406IN	DOCKS	262	A+, A, B
4407OT	DOCKS	264	A+, A, B
4408OT	DOCKS	264	A+, A, B
4409OT	DOCKS	264	A+, A, B
4411BI	MAGNUM	317	A++, A+, A, B, C, D, E
4411GR	MAGNUM	317	A++, A+, A, B, C, D, E
4412BI	MAGNUM	317	A++, A+, A, B, C, D, E
4412GR	MAGNUM	317	A++, A+, A, B, C, D, E
4413IN	DOCKS	263	A+
4414OT	DOCKS	265	A+
4415OT	DOCKS	265	A+
4416OT	DOCKS	265	A+
4417OT	DOCKS	265	A+
4420NE	JACK	292	A+, A, B
4424GM.BL	FEELING	285	A+, A, B
4424GM.OP	FEELING	285	A+, A, B
4424GM.VE	FEELING	285	A+, A, B
4424GR.BL	FEELING	285	A+, A, B
4424GR.OP	FEELING	285	A+, A, B
4424GR.VE	FEELING	285	A+, A, B
4427GM.BL	FEELING	317	A++, A+, A, B, C, D, E
4427GM.OP	FEELING	317	A++, A+, A, B, C, D, E
4427GM.VE	FEELING	317	A++, A+, A, B, C, D, E
4427GR.BL	FEELING	317	A++, A+, A, B, C, D, E
4427GR.OP	FEELING	317	A++, A+, A, B, C, D, E
4427GR.VE	FEELING	317	A++, A+, A, B, C, D, E
4428GM.BL	FEELING	317	A++, A+, A, B, C, D, E
4428GM.OP	FEELING	317	A++, A+, A, B, C, D, E
4428GM.VE	FEELING	317	A++, A+, A, B, C, D, E
4428GR.BL	FEELING	317	A++, A+, A, B, C, D, E
4428GR.OP	FEELING	317	A++, A+, A, B, C, D, E
4428GR.VE	FEELING	317	A++, A+, A, B, C, D, E
4429GM	FEELING	285	A+, A, B
4429GR	FEELING	285	A+, A, B
4431GR	TRIANGOLO	148	A+, A, B
4431SI	TRIANGOLO	148	A+, A, B
4432GR	TRIANGOLO	148	A+, A, B
4432SI	TRIANGOLO	148	A+, A, B
4433GR	TRIANGOLO	149	A+, A, B
4433SI	TRIANGOLO	149	A+, A, B
4434GR	TRIANGOLO	149	A+, A, B
4434SI	TRIANGOLO	149	A+, A, B

Indice articoli e Classi Energetiche | Code index and Energy class

COD.	SERIE	PAG.	CLASSE ENERGETICA ENERGY CLASS	COD.	SERIE	PAG.	CLASSE ENERGETICA ENERGY CLASS
CODE	RANGE	PAGE		CODE	RANGE	PAGE	
4435GR	TRIANGOLO	150	A+, A, B	4464IN	DOCKS	262	A+, A, B
4435SI	TRIANGOLO	150	A+, A, B	4466IN	DOCKS	262	A+, A, B
4436GR	TRIANGOLO	150	A+, A, B	4468OT	DOCKS	264	A+, A, B
4436SI	TRIANGOLO	150	A+, A, B	4469OT	DOCKS	264	A+, A, B
4438GM.BL	FEELING	285	A++	4470BI	DOCKS	261	A+
4438GM.OP	FEELING	285	A++	4470GM	DOCKS	261	A+
4438GM.VE	FEELING	285	A++	4470GR	DOCKS	261	A+
4438GR.BL	FEELING	285	A++	4472BI	DOCKS	261	A+
4438GR.OP	FEELING	285	A++	4472GM	DOCKS	261	A+
4438GR.VE	FEELING	285	A++	4472GR	DOCKS	261	A+
4439GM	FEELING	285	A++	4473NE	SMALL MIDI MAXI & SUPERMAXI	130	A+, A, B
4439GR	FEELING	285	A++	4473SI	SMALL MIDI MAXI & SUPERMAXI	130	A+, A, B
4440GM	FEELING	285/319	A++	4474IN	DOCKS	263	A+
4440GR	FEELING	285/319	A++	4475IN	DOCKS	263	A+
4441GM.BL	FEELING	285/319	A++	4476OT	DOCKS	265	A+
4441GM.OP	FEELING	285/319	A++	4477OT	DOCKS	265	A+
4441GM.VE	FEELING	285/319	A++	4478BI	DOCKS	261	A+
4441GR.BL	FEELING	285/319	A++	4478GM	DOCKS	261	A+
4441GR.OP	FEELING	285/319	A++	4478GR	DOCKS	261	A+
4441GR.VE	FEELING	285/319	A++	4479BI	DOCKS	261	A+
4442BI	MAGNUM	309	A++	4479GM	DOCKS	261	A+
4442GR	MAGNUM	309	A++	4479GR	DOCKS	261	A+
4443BI	MAGNUM	309/318	A++	4480BI	DOCKS	261	A+
4443GR	MAGNUM	309/318	A++	4480GM	DOCKS	261	A+
4444BI	MARINA	304	A+, A, B	4480GR	DOCKS	261	A+
4444GR	MARINA	304	A+, A, B	4481BI	DOCKS	261	A+
4447BI	MARINA	304	A+, A, B	4481GM	DOCKS	261	A+
4447GR	MARINA	304	A+, A, B	4481GR	DOCKS	261	A+
4448BI	MAGNUM	309	A++	4483BI	KASKO	272	A+, A, B
4448GR	MAGNUM	309	A++	4483GR	KASKO	272	A+, A, B
4449BI	MAGNUM	309	A++	4483SI	KASKO	272	A+, A, B
4449GR	MAGNUM	309	A++	4484BI	KASKO	270	A+, A, B
4450NE	SMALL MIDI MAXI & SUPERMAXI	134	A+	4484GR	KASKO	270	A+, A, B
4450SI	SMALL MIDI MAXI & SUPERMAXI	134	A+	4484SI	KASKO	270	A+, A, B
4451NE	JACK LED	296	A+	4486BI	KASKO	274	A+, A, B
4453NE	JACK LED	296	A+	4486GR	KASKO	274	A+, A, B
4459OT	DOCKS	264	A+, A, B	4486SI	KASKO	274	A+, A, B
4460BI	DOCKS	260	A+, A, B	4487IN	DOCKS	263	A+
4460GM	DOCKS	260	A+, A, B	4488IN	DOCKS	263	A+
4460GR	DOCKS	260	A+, A, B	4489IN	DOCKS	263	A+
4461BI	DOCKS	260	A+, A, B	4490BI	KASKO	270	A+, A, B
4461GM	DOCKS	260	A+, A, B	4490GR	KASKO	270	A+, A, B
4461GR	DOCKS	260	A+, A, B	4490SI	KASKO	270	A+, A, B
4462BI	DOCKS	260	A+, A, B	4491BI	KASKO	272	A+, A, B
4462GM	DOCKS	260	A+, A, B	4491GR	KASKO	272	A+, A, B
4462GR	DOCKS	260	A+, A, B	4491SI	KASKO	272	A+, A, B
4463IN	DOCKS	262	A+, A, B	4492BI	KASKO	274	A+, A, B

Indice articoli e Classi Energetiche | Code index and Energy class

COD. CODE	SERIE RANGE	PAG. PAGE	CLASSE ENERGETICA ENERGY CLASS
4492GR	KASKO	274	A+, A, B
4492SI	KASKO	274	A+, A, B
4493BI	MAGNUM	309	A+, A, B
4493GR	MAGNUM	309	A+, A, B
4494BI	MAGNUM	309	A+, A, B
4494GR	MAGNUM	309	A+, A, B
4496BI	MARINA	304	A+, A, B
4496GR	MARINA	304	A+, A, B
4497BI	MARINA	304	A+, A, B
4497GR	MARINA	304	A+, A, B
4499NE	JACK	292	A+, A, B
4510BI	MARINA	303	A++, A+, A, B, C, D, E
4510GR	MARINA	303	A++, A+, A, B, C, D, E
4513BI	MARINA	303	A+, A, B
4513GR	MARINA	303	A+, A, B
4520BI	MARINA	303	A++, A+, A, B, C, D, E
4520GR	MARINA	303	A++, A+, A, B, C, D, E
4546BI	MARINA	303	A+, A, B
4546GR	MARINA	303	A+, A, B
4549BI	MARINA	303	A+, A, B
4549GR	MARINA	303	A+, A, B
4560BI	MARINA	303	A++, A+, A, B, C, D, E
4560GR	MARINA	303	A++, A+, A, B, C, D, E
4566BI	MARINA	303	A+, A, B
4566GR	MARINA	303	A+, A, B
4580BI	MARINA	303	A++, A+, A, B, C, D, E
4580GR	MARINA	303	A++, A+, A, B, C, D, E
4586BI	MARINA	303	A+, A, B
4586GR	MARINA	303	A+, A, B
4589BI	MARINA	303	A+, A, B
4589GR	MARINA	303	A+, A, B
4590BI	MARINA	303	A++, A+, A, B, C, D, E
4590GR	MARINA	303	A++, A+, A, B, C, D, E
4592BI	MARINA	303	A++, A+, A, B, C, D, E
4592GR	MARINA	303	A++, A+, A, B, C, D, E
4593BI	MARINA	303	A+, A, B
4593GR	MARINA	303	A+, A, B
4594BI	MARINA	303	A+, A, B
4594GR	MARINA	303	A+, A, B
4596BI	MARINA	303	A+, A, B
4596GR	MARINA	303	A+, A, B
4598BI	MARINA	303	A+, A, B
4598GR	MARINA	303	A+, A, B
4603SI	STRIKE 1	226	A++, A+, A, C, D
4604SI	STRIKE 1	226	A+
4607SI	STRIKE 1	227	A++, A+, A, C, D
4608SI	STRIKE 1	227	A+
4613SI	STRIKE 2	230	A+
4614SI	STRIKE 2	230	A+

COD. CODE	SERIE RANGE	PAG. PAGE	CLASSE ENERGETICA ENERGY CLASS
4618SI	STRIKE 2	230	A+
4619SI	STRIKE 2	231	A+
4622SI	STRIKE 2	231	A+
4623SI	STRIKE 2	231	A+
4633NE	TRIALO	255	A+, A, B
4633SI	TRIALO	255	A+, A, B
4652SI	STRIKE 2	233	
4654AR	STRIKE 2	233	
4654BL	STRIKE 2	233	
4654GI	STRIKE 2	233	
4654RO	STRIKE 2	233	
4654VE	STRIKE 2	233	
4655	STRIKE 2	233	
4656	STRIKE 2	233	
4661GM	CLOCK	216	A++
4661GR	CLOCK	216	A++
4664GM	CLOCK	216	A++
4664GR	CLOCK	216	A++
4675NE	TRIALO	255	A++
4675SI	TRIALO	255	A++
4691GM	CLOCK	218	
4691GR	CLOCK	218	
4692GM	CLOCK	218	
4720BI	MARINA	304	A++, A+, A, B, C, D, E
4720GR	MARINA	304	A++, A+, A, B, C, D, E
4742BI	MARINA	304	A+, A, B
4742GR	MARINA	304	A+, A, B
4746BI	MARINA	304	A+, A, B
4746GR	MARINA	304	A+, A, B
4749BI	MARINA	304	A+, A, B
4749GR	MARINA	304	A+, A, B
4780BI	MARINA	304	A++, A+, A, B, C, D, E
4780GR	MARINA	304	A++, A+, A, B, C, D, E
4782BI	MARINA	304	A+, A, B
4782GR	MARINA	304	A+, A, B
4786BI	MARINA	304	A+, A, B
4786GR	MARINA	304	A+, A, B
4789BI	MARINA	304	A+, A, B
4789GR	MARINA	304	A+, A, B
4790BI	MARINA	304	A++, A+, A, B, C, D, E
4790GR	MARINA	304	A++, A+, A, B, C, D, E
4792BI	MARINA	304	A++, A+, A, B, C, D, E
4792GR	MARINA	304	A++, A+, A, B, C, D, E
4793BI	MARINA	304	A+, A, B
4793GR	MARINA	304	A+, A, B
4794BI	MARINA	304	A+, A, B
4794GR	MARINA	304	A+, A, B
4796BI	MARINA	304	A+, A, B
4796GR	MARINA	304	A+, A, B

Indice articoli e Classi Energetiche | Code index and Energy class

COD. CODE	SERIE RANGE	PAG. PAGE	CLASSE ENERGETICA ENERGY CLASS	COD. CODE	SERIE RANGE	PAG. PAGE	CLASSE ENERGETICA ENERGY CLASS
4798BI	MARINA	304	A+, A, B	5080NE	SMALL MIDI MAXI		
4798GR	MARINA	304	A+, A, B		& SUPERMAXI	138/211	
4821GM	FEELING	285	A++	5080SI	SMALL MIDI MAXI		
4821GR	FEELING	285	A++		& SUPERMAXI	138/211	
4825GM	FEELING	285/319	A++	5091NE	SMALL MIDI MAXI		
4825GR	FEELING	285/319	A++		& SUPERMAXI	138	
4832GM.BL	FEELING	285	A++	5091SI	SMALL MIDI MAXI		
4832GM.OP	FEELING	285	A++		& SUPERMAXI	138	
4832GM.VE	FEELING	285	A++	5212NE	SMALL MIDI MAXI		
4832GR.BL	FEELING	285	A++		& SUPERMAXI	135	A+
4832GR.OP	FEELING	285	A++	5212SI	SMALL MIDI MAXI		
4832GR.VE	FEELING	285	A++		& SUPERMAXI	135	A+
4836GM.BL	FEELING	285/319	A++	5213NE	SMALL MIDI MAXI		
4836GM.OP	FEELING	285/319	A++		& SUPERMAXI	135	A+
4836GM.VE	FEELING	285/319	A++	5213SI	SMALL MIDI MAXI		
4836GR.BL	FEELING	285/319	A++		& SUPERMAXI	135	A+
4836GR.OP	FEELING	285/319	A++	5221NE	SMALL MIDI MAXI		
4836GR.VE	FEELING	285/319	A++		& SUPERMAXI	135	A+
4881GM	FEELING	285	A++, A+, A, B, C, D, E	5221SI	SMALL MIDI MAXI		
4881GR	FEELING	285	A++, A+, A, B, C, D, E		& SUPERMAXI	135	A+
4883GM	FEELING	285	A+, A, B	5223NE	SMALL MIDI MAXI		
4883GR	FEELING	285	A+, A, B		& SUPERMAXI	135	A+
4890GM.BL	FEELING	285	A++, A+, A, B, C, D, E	5223SI	SMALL MIDI MAXI		
4890GM.OP	FEELING	285	A++, A+, A, B, C, D, E		& SUPERMAXI	135	A+
4890GM.VE	FEELING	285	A++, A+, A, B, C, D, E	5232NE	SMALL MIDI MAXI		
4890GR.BL	FEELING	285	A++, A+, A, B, C, D, E		& SUPERMAXI	135	A+
4890GR.OP	FEELING	285	A++, A+, A, B, C, D, E	5232SI	SMALL MIDI MAXI		
4890GR.VE	FEELING	285	A++, A+, A, B, C, D, E		& SUPERMAXI	135	A+
4894GM.BL	FEELING	285	A+, A, B	5233NE	SMALL MIDI MAXI		
4894GM.OP	FEELING	285	A+, A, B		& SUPERMAXI	135	A+
4894GM.VE	FEELING	285	A+, A, B	5233SI	SMALL MIDI MAXI		
4894GR.BL	FEELING	285	A+, A, B		& SUPERMAXI	135	A+
4894GR.OP	FEELING	285	A+, A, B	5301GR	SERVER POINT	122	
4894GR.VE	FEELING	285	A+, A, B	5302GR	SERVER POINT	122	
5002	COMPATTA	87		5303GR	SERVER POINT	122	
5022GM	COMPATTA	86	A+, A, B	5308GR	SERVER POINT	123	
5022GR	COMPATTA	86	A+, A, B	5309	SERVER POINT	123	
5024GM	COMPATTA	86	A+	5315GR	SERVER POINT	123	A++
5024GR	COMPATTA	86	A+	5401GM	QUANTUM	45	
5025GM	COMPATTA	86	A+	5401GR	QUANTUM	45	
5025GR	COMPATTA	86	A+	5402	QUANTUM	45	
5026GM	COMPATTA	86	A+	5405GM	QUANTUM	45	
5026GR	COMPATTA	86	A+	5405GR	QUANTUM	45	
5032GM	COMPATTA	86	A+, A, B	5406GM	QUANTUM	45	
5032GR	COMPATTA	86	A+, A, B	5406GR	QUANTUM	45	
5034GM	COMPATTA	86	A+	5407	QUANTUM	45	
5034GR	COMPATTA	86	A+	5411GM	QUANTUM	42	
5066NE	VOLTO	211		5411GR	QUANTUM	42	
5066SI	VOLTO	211		5412GM	QUANTUM	42	

Indice articoli e Classi Energetiche | Code index and Energy class

COD. CODE	SERIE RANGE	PAG. PAGE	CLASSE ENERGETICA ENERGY CLASS
5412GR	QUANTUM	42	
5415GM	QUANTUM	42	
5415GR	QUANTUM	42	
5416GM	QUANTUM	42	
5416GR	QUANTUM	42	
5420	QUANTUM	34	A++
5421	QUANTUM	34	A++
5425	QUANTUM	34	A++
5430	QUANTUM	35	A++
5435	QUANTUM	35	A++
5440	QUANTUM	35	A++
5441OP	QUANTUM	40	
5442OP	QUANTUM	40	
5443OP	QUANTUM	40	
5444OP	QUANTUM	40	
5452GR	QUANTUM	37	
5453GR	QUANTUM	37	
5454GR	QUANTUM	37	
5455GR	QUANTUM	37	
5460BI	QUANTUM	38	
5460GM	QUANTUM	38	
5460GR	QUANTUM	38	
5462BI	QUANTUM	38	
5462GM	QUANTUM	38	
5462GR	QUANTUM	38	
5463BI	QUANTUM	38	
5463GM	QUANTUM	38	
5463GR	QUANTUM	38	
5464BI	QUANTUM	38	
5464GM	QUANTUM	38	
5464GR	QUANTUM	38	
5465BI	QUANTUM	38	
5465GM	QUANTUM	38	
5465GR	QUANTUM	38	
5466BI	QUANTUM	38	
5466GM	QUANTUM	38	
5466GR	QUANTUM	38	
5467BI	QUANTUM	38	
5467GM	QUANTUM	38	
5467GR	QUANTUM	38	
5472IN	QUANTUM	39	
5473IN	QUANTUM	39	
5474IN	QUANTUM	39	
5475IN	QUANTUM	39	
5476IN	QUANTUM	39	
5477IN	QUANTUM	39	
5480	QUANTUM	36	
5481	QUANTUM	36	
5482	QUANTUM	36	

COD. CODE	SERIE RANGE	PAG. PAGE	CLASSE ENERGETICA ENERGY CLASS
5483AR	QUANTUM	36	
5483BL	QUANTUM	36	
5483VE	QUANTUM	36	
5484AR	QUANTUM	36	
5484BL	QUANTUM	36	
5484VE	QUANTUM	36	
5485AR	QUANTUM	36	
5485BL	QUANTUM	36	
5485VE	QUANTUM	36	
5486AR	QUANTUM	36	
5486BL	QUANTUM	36	
5486VE	QUANTUM	36	
5487AR	QUANTUM	36	
5487BL	QUANTUM	36	
5487VE	QUANTUM	36	
5496	QUANTUM	46	
5500IN	I-MAGO	110	A+
5501GR	I-LUX	102	A+, A, B
5502GR	I-LUX	102	A+, A, B
5503IN	I-LUX	103	A+, A, B
5504IN	I-LUX	103	A+, A, B
5505	I-LUX	97/105/111/117	
5506	CANTHARELLUS	97	
5507	I-LUX	105/111	
5508GR	I-LUX	102	A+, A, B
5509IN	I-LUX	103	A+, A, B
5510GR	I-MAGO	110	A+
5511GR	I-LUX	102	
5512IN	I-LUX	103	
5515GR	I-LUX	102	
5516IN	I-LUX	103	
5519	I-LUX	97/105/111/117	
5521GM	CANTHARELLUS	96	A++
5521GR	CANTHARELLUS	96	A++
5522GM	CANTHARELLUS	96	A++
5522GR	CANTHARELLUS	96	A++
5526GM	STANDING	81	A+
5526GR	STANDING	81	A+
5529	STANDING	48/81	
5531AR	I-DEA	116	
5531BL	I-DEA	116	
5531OP	I-DEA	116	
5531VE	I-DEA	116	
5534AM.BR	I-DEA	116	
5534BL.ZR	I-DEA	116	
5534VE.SM	I-DEA	116	
5536GR	I-DEA	116	A++, A+, A, B, C, D, E
5537GR	I-DEA	116	A+
5591GM	QUANTUM	46	A++

Indice articoli e Classi Energetiche | Code index and Energy class

COD. CODE	SERIE RANGE	PAG. PAGE	CLASSE ENERGETICA ENERGY CLASS	COD. CODE	SERIE RANGE	PAG. PAGE	CLASSE ENERGETICA ENERGY CLASS
5591GR	QUANTUM	46	A++	5637NE	SMALL MIDI MAXI		
5593GM	QUANTUM	48	A+		& SUPERMAXI	131	A+, A, B
5593GR	QUANTUM	48	A+	5637SI	SMALL MIDI MAXI		
5594GM	QUANTUM	48	A+		& SUPERMAXI	131	A+, A, B
5594GR	QUANTUM	48	A+	5638NE	SMALL MIDI MAXI		
5596GM	QUANTUM	50	A++		& SUPERMAXI	134	A+
5596GR	QUANTUM	50	A++	5638SI	SMALL MIDI MAXI		
5597GM	QUANTUM	48	A+		& SUPERMAXI	134	A+
5597GR	QUANTUM	48	A+	5652NE	SMALL MIDI MAXI		
5598GM	QUANTUM	50	A++		& SUPERMAXI	130	A+, A, B
5598GR	QUANTUM	50	A++	5652SI	SMALL MIDI MAXI		
5599GM	QUANTUM	48	A+		& SUPERMAXI	130	A+, A, B
5599GR	QUANTUM	48	A+	5653NE	SMALL MIDI MAXI		
5606NE	SMALL MIDI MAXI				& SUPERMAXI	131	A+, A, B
	& SUPERMAXI	130	A++, A+, A, B, C, D, E	5653SI	SMALL MIDI MAXI		
5606SI	SMALL MIDI MAXI				& SUPERMAXI	131	A+, A, B
	& SUPERMAXI	130	A++, A+, A, B, C, D, E	5662NE	SMALL MIDI MAXI		
5607NE	SMALL MIDI MAXI				& SUPERMAXI	132	A+, A, B
	& SUPERMAXI	131	A++, A+, A, B, C, D, E	5662SI	SMALL MIDI MAXI		
5607SI	SMALL MIDI MAXI				& SUPERMAXI	132	A+, A, B
	& SUPERMAXI	131	A++, A+, A, B, C, D, E	5663NE	SMALL MIDI MAXI		
5608NE	SMALL MIDI MAXI				& SUPERMAXI	132	A+
	& SUPERMAXI	134	A+	5663SI	SMALL MIDI MAXI		
5608SI	SMALL MIDI MAXI				& SUPERMAXI	132	A+
	& SUPERMAXI	134	A+	5666NE	SMALL MIDI MAXI		
5618NE	SMALL MIDI MAXI				& SUPERMAXI	132	A+
	& SUPERMAXI	130	A+, A, B	5666SI	SMALL MIDI MAXI		
5618SI	SMALL MIDI MAXI				& SUPERMAXI	132	A+
	& SUPERMAXI	130	A+, A, B	5667NE	SMALL MIDI MAXI		
5619NE	SMALL MIDI MAXI				& SUPERMAXI	132	A
	& SUPERMAXI	131	A+, A, B	5667SI	SMALL MIDI MAXI		
5619SI	SMALL MIDI MAXI				& SUPERMAXI	132	A
	& SUPERMAXI	131	A+, A, B	5669NE	SMALL MIDI MAXI		
5621NE	SMALL MIDI MAXI				& SUPERMAXI	132	A+
	& SUPERMAXI	134	A+	5669SI	SMALL MIDI MAXI		
5621SI	SMALL MIDI MAXI				& SUPERMAXI	132	A+
	& SUPERMAXI	134	A+	5672NE	SMALL MIDI MAXI		
5626NE	SMALL MIDI MAXI				& SUPERMAXI	132	A+
	& SUPERMAXI	130	A+, A, B	5672SI	SMALL MIDI MAXI		
5626SI	SMALL MIDI MAXI				& SUPERMAXI	132	A+
	& SUPERMAXI	130	A+, A, B	5673NE	SMALL MIDI MAXI		
5627NE	SMALL MIDI MAXI				& SUPERMAXI	132	A
	& SUPERMAXI	131	A+, A, B	5673SI	SMALL MIDI MAXI		
5627SI	SMALL MIDI MAXI				& SUPERMAXI	132	A
	& SUPERMAXI	131	A+, A, B	5675NE	SMALL MIDI MAXI		
5636NE	SMALL MIDI MAXI				& SUPERMAXI	132	A+
	& SUPERMAXI	130	A+, A, B	5675SI	SMALL MIDI MAXI		
5636SI	SMALL MIDI MAXI				& SUPERMAXI	132	A+
	& SUPERMAXI	130	A+, A, B				

COD. CODE	SERIE RANGE	PAG. PAGE	CLASSE ENERGETICA ENERGY CLASS
5678NE	SMALL MIDI MAXI & SUPERMAXI	132	A+
5678SI	SMALL MIDI MAXI & SUPERMAXI	132	A+
5680NE	SMALL MIDI MAXI & SUPERMAXI	133	A+, A, B
5680SI	SMALL MIDI MAXI & SUPERMAXI	133	A+, A, B
5681NE	SMALL MIDI MAXI & SUPERMAXI	133	A+
5681SI	SMALL MIDI MAXI & SUPERMAXI	133	A+
5683NE	SMALL MIDI MAXI & SUPERMAXI	133	A+
5683SI	SMALL MIDI MAXI & SUPERMAXI	133	A+
5684NE	SMALL MIDI MAXI & SUPERMAXI	133	A
5684SI	SMALL MIDI MAXI & SUPERMAXI	133	A
5685NE	SMALL MIDI MAXI & SUPERMAXI	133	A+
5685SI	SMALL MIDI MAXI & SUPERMAXI	133	A+
5687NE	SMALL MIDI MAXI & SUPERMAXI	133	A+
5687SI	SMALL MIDI MAXI & SUPERMAXI	133	A+
5688NE	SMALL MIDI MAXI & SUPERMAXI	133	A
5688SI	SMALL MIDI MAXI & SUPERMAXI	133	A
5689NE	SMALL MIDI MAXI & SUPERMAXI	133	A+
5689SI	SMALL MIDI MAXI & SUPERMAXI	133	A+
5692NE	SMALL MIDI MAXI & SUPERMAXI	137	
5693NE	SMALL MIDI MAXI & SUPERMAXI	137	
5694NE	SMALL MIDI MAXI & SUPERMAXI	137	
5696NE	SMALL MIDI MAXI & SUPERMAXI	137	
5699NE	SMALL MIDI MAXI & SUPERMAXI	133	A+
5699SI	SMALL MIDI MAXI & SUPERMAXI	133	A+

COD. CODE	SERIE RANGE	PAG. PAGE	CLASSE ENERGETICA ENERGY CLASS
5700NE	SMALL MIDI MAXI & SUPERMAXI	136	
5700SI	SMALL MIDI MAXI & SUPERMAXI	136	
5704NE	SMALL MIDI MAXI & SUPERMAXI	136	
5704SI	SMALL MIDI MAXI & SUPERMAXI	136	
5705NE	SMALL MIDI MAXI & SUPERMAXI	137	
5705SI	SMALL MIDI MAXI & SUPERMAXI	137	
5708NE	SMALL MIDI MAXI & SUPERMAXI	137	
5708SI	SMALL MIDI MAXI & SUPERMAXI	137	
5861NE	VOLTO	210	A+
5861SI	VOLTO	210	A+
5863NE	VOLTO	210	A+
5863SI	VOLTO	210	A+
5864NE	VOLTO	211	
5864SI	VOLTO	211	
7106GM.BL FEELING		317	A++, A+, A, B, C, D, E
7106GM.OP FEELING		317	A++, A+, A, B, C, D, E
7106GM.VE FEELING		317	A++, A+, A, B, C, D, E
7106GR.BL FEELING		317	A++, A+, A, B, C, D, E
7106GR.OP FEELING		317	A++, A+, A, B, C, D, E
7106GR.VE FEELING		317	A++, A+, A, B, C, D, E
7107GM.BL FEELING		317	A++, A+, A, B, C, D, E
7107GM.OP FEELING		317	A++, A+, A, B, C, D, E
7107GM.VE FEELING		317	A++, A+, A, B, C, D, E
7107GR.BL FEELING		317	A++, A+, A, B, C, D, E
7107GR.OP FEELING		317	A++, A+, A, B, C, D, E
7107GR.VE FEELING		317	A++, A+, A, B, C, D, E
7108BI	KASKO	316	A++, A+, A, B, C, D, E
7108GR	KASKO	316	A++, A+, A, B, C, D, E
7108SI	KASKO	316	A++, A+, A, B, C, D, E
7109BI	KASKO	316	A++, A+, A, B, C, D, E
7109GR	KASKO	316	A++, A+, A, B, C, D, E
7109SI	KASKO	316	A++, A+, A, B, C, D, E
7111BI	MAGNUM	317	A++, A+, A, B, C, D, E
7111GR	MAGNUM	317	A++, A+, A, B, C, D, E
7112BI	MAGNUM	317	A++, A+, A, B, C, D, E
7112GR	MAGNUM	317	A++, A+, A, B, C, D, E
7113BI	MARINA	316	A++, A+, A, B, C, D, E
7113GR	MARINA	316	A++, A+, A, B, C, D, E
7114BI	MARINA	316	A++, A+, A, B, C, D, E
7114GR	MARINA	316	A++, A+, A, B, C, D, E
7115GM	FEELING	317	A++, A+, A, B, C, D, E

Indice articoli e Classi Energetiche | Code index and Energy class

COD.	SERIE	PAG.	CLASSE ENERGETICA	COD.	SERIE	PAG.	CLASSE ENERGETICA
CODE	RANGE	PAGE	ENERGY CLASS	CODE	RANGE	PAGE	ENERGY CLASS
7115GR	FEELING	317	A++, A+, A, B, C, D, E	8296SI	KASKO	276	A+, A, B
7116GM	FEELING	317	A++, A+, A, B, C, D, E	8298BI	KASKO	276	A+, A, B
7116GR	FEELING	317	A++, A+, A, B, C, D, E	8298GR	KASKO	276	A+, A, B
7117GM	FEELING	317	A++, A+, A, B, C, D, E	8298SI	KASKO	276	A+, A, B
7117GR	FEELING	317	A++, A+, A, B, C, D, E	8310BI	KASKO	272	A++, A+, A, B, C, D, E
7118GM	FEELING	317	A++, A+, A, B, C, D, E	8310GR	KASKO	272	A++, A+, A, B, C, D, E
7118GR	FEELING	317	A++, A+, A, B, C, D, E	8310SI	KASKO	272	A++, A+, A, B, C, D, E
7191BI	KASKO	316	A++, A+, A, B, C, D, E	8311BI	KASKO	272	A+, A, B
7191GR	KASKO	316	A++, A+, A, B, C, D, E	8311GR	KASKO	272	A+, A, B
7191SI	KASKO	316	A++, A+, A, B, C, D, E	8311SI	KASKO	272	A+, A, B
7192BI	KASKO	316	A++, A+, A, B, C, D, E	8320BI	KASKO	272	A++, A+, A, B, C, D, E
7192GR	KASKO	316	A++, A+, A, B, C, D, E	8320GR	KASKO	272	A++, A+, A, B, C, D, E
7192SI	KASKO	316	A++, A+, A, B, C, D, E	8320SI	KASKO	272	A++, A+, A, B, C, D, E
7193BI	MARINA	316	A++, A+, A, B, C, D, E	8322BI	KASKO	272	A+, A, B
7193GR	MARINA	316	A++, A+, A, B, C, D, E	8322GR	KASKO	272	A+, A, B
7194BI	MARINA	316	A++, A+, A, B, C, D, E	8322SI	KASKO	272	A+, A, B
7194GR	MARINA	316	A++, A+, A, B, C, D, E	8326BI	KASKO	272	A+, A, B
8110BI	KASKO	276	A++, A+, A, B, C, D, E	8326GR	KASKO	272	A+, A, B
8110GR	KASKO	276	A++, A+, A, B, C, D, E	8326SI	KASKO	272	A+, A, B
8110SI	KASKO	276	A++, A+, A, B, C, D, E	8328BI	KASKO	272	A+, A, B
8116BI	KASKO	276	A+, A, B	8328GR	KASKO	272	A+, A, B
8116GR	KASKO	276	A+, A, B	8328SI	KASKO	272	A+, A, B
8116SI	KASKO	276	A+, A, B	8390BI	KASKO	272	A++, A+, A, B, C, D, E
8118BI	KASKO	276	A+, A, B	8390GR	KASKO	272	A++, A+, A, B, C, D, E
8118GR	KASKO	276	A+, A, B	8390SI	KASKO	272	A++, A+, A, B, C, D, E
8118SI	KASKO	276	A+, A, B	8391BI	KASKO	272	A+, A, B
8190BI	KASKO	276	A++, A+, A, B, C, D, E	8391GR	KASKO	272	A+, A, B
8190GR	KASKO	276	A++, A+, A, B, C, D, E	8391SI	KASKO	272	A+, A, B
8190SI	KASKO	276	A++, A+, A, B, C, D, E	8395BI	KASKO	272	A++, A+, A, B, C, D, E
8196BI	KASKO	276	A+, A, B	8395GR	KASKO	272	A++, A+, A, B, C, D, E
8196GR	KASKO	276	A+, A, B	8395SI	KASKO	272	A++, A+, A, B, C, D, E
8196SI	KASKO	276	A+, A, B	8396BI	KASKO	272	A+, A, B
8198BI	KASKO	276	A+, A, B	8396GR	KASKO	272	A+, A, B
8198GR	KASKO	276	A+, A, B	8396SI	KASKO	272	A+, A, B
8198SI	KASKO	276	A+, A, B	8397BI	KASKO	272	A+, A, B
8210BI	KASKO	276	A++, A+, A, B, C, D, E	8397GR	KASKO	272	A+, A, B
8210GR	KASKO	276	A++, A+, A, B, C, D, E	8397SI	KASKO	272	A+, A, B
8210SI	KASKO	276	A++, A+, A, B, C, D, E	8410BI	KASKO	270	A++, A+, A, B, C, D, E
8216BI	KASKO	276	A+, A, B	8410GR	KASKO	270	A++, A+, A, B, C, D, E
8216GR	KASKO	276	A+, A, B	8410SI	KASKO	270	A++, A+, A, B, C, D, E
8216SI	KASKO	276	A+, A, B	8411BI	KASKO	270	A+, A, B
8218BI	KASKO	276	A+, A, B	8411GR	KASKO	270	A+, A, B
8218GR	KASKO	276	A+, A, B	8411SI	KASKO	270	A+, A, B
8218SI	KASKO	276	A+, A, B	8420BI	KASKO	270	A++, A+, A, B, C, D, E
8290BI	KASKO	276	A++, A+, A, B, C, D, E	8420GR	KASKO	270	A++, A+, A, B, C, D, E
8290GR	KASKO	276	A++, A+, A, B, C, D, E	8420SI	KASKO	270	A++, A+, A, B, C, D, E
8290SI	KASKO	276	A++, A+, A, B, C, D, E	8422BI	KASKO	270	A+, A, B
8296BI	KASKO	276	A+, A, B	8422GR	KASKO	270	A+, A, B
8296GR	KASKO	276	A+, A, B	8422SI	KASKO	270	A+, A, B

Indice articoli e Classi Energetiche | Code index and Energy class

COD. CODE	SERIE RANGE	PAG. PAGE	CLASSE ENERGETICA ENERGY CLASS
8426BI	KASKO	270	A+, A, B
8426GR	KASKO	270	A+, A, B
8426SI	KASKO	270	A+, A, B
8428BI	KASKO	270	A+, A, B
8428GR	KASKO	270	A+, A, B
8428SI	KASKO	270	A+, A, B
8490BI	KASKO	270	A++, A+, A, B, C, D, E
8490GR	KASKO	270	A++, A+, A, B, C, D, E
8490SI	KASKO	270	A++, A+, A, B, C, D, E
8491BI	KASKO	270	A+, A, B
8491GR	KASKO	270	A+, A, B
8491SI	KASKO	270	A+, A, B
8495BI	KASKO	270	A++, A+, A, B, C, D, E
8495GR	KASKO	270	A++, A+, A, B, C, D, E
8495SI	KASKO	270	A++, A+, A, B, C, D, E
8496BI	KASKO	270	A+, A, B
8496GR	KASKO	270	A+, A, B
8496SI	KASKO	270	A+, A, B
8497BI	KASKO	270	A+, A, B
8497GR	KASKO	270	A+, A, B
8497SI	KASKO	270	A+, A, B
8610BI	KASKO	274	A++, A+, A, B, C, D, E
8610GR	KASKO	274	A++, A+, A, B, C, D, E
8610SI	KASKO	274	A++, A+, A, B, C, D, E
8611BI	KASKO	274	A+, A, B
8611GR	KASKO	274	A+, A, B
8611SI	KASKO	274	A+, A, B
8620BI	KASKO	274	A++, A+, A, B, C, D, E
8620GR	KASKO	274	A++, A+, A, B, C, D, E
8620SI	KASKO	274	A++, A+, A, B, C, D, E
8626BI	KASKO	274	A+, A, B
8626GR	KASKO	274	A+, A, B
8626SI	KASKO	274	A+, A, B
8628BI	KASKO	274	A+, A, B
8628GR	KASKO	274	A+, A, B
8628SI	KASKO	274	A+, A, B
8690BI	KASKO	274	A++, A+, A, B, C, D, E
8690GR	KASKO	274	A++, A+, A, B, C, D, E
8690SI	KASKO	274	A++, A+, A, B, C, D, E
8691BI	KASKO	274	A+, A, B
8691GR	KASKO	274	A+, A, B
8691SI	KASKO	274	A+, A, B
8695BI	KASKO	274	A++, A+, A, B, C, D, E
8695GR	KASKO	274	A++, A+, A, B, C, D, E
8695SI	KASKO	274	A++, A+, A, B, C, D, E
8696BI	KASKO	274	A+, A, B
8696GR	KASKO	274	A+, A, B
8696SI	KASKO	274	A+, A, B
8697BI	KASKO	274	A+, A, B

COD. CODE	SERIE RANGE	PAG. PAGE	CLASSE ENERGETICA ENERGY CLASS
8697GR	KASKO	274	A+, A, B
8697SI	KASKO	274	A+, A, B
8810BI	KASKO	277	A++, A+, A, B, C, D, E
8810GR	KASKO	277	A++, A+, A, B, C, D, E
8810SI	KASKO	277	A++, A+, A, B, C, D, E
8816BI	KASKO	277	A+, A, B
8816GR	KASKO	277	A+, A, B
8816SI	KASKO	277	A+, A, B
8818BI	KASKO	277	A+, A, B
8818GR	KASKO	277	A+, A, B
8818SI	KASKO	277	A+, A, B
8890BI	KASKO	277	A++, A+, A, B, C, D, E
8890GR	KASKO	277	A++, A+, A, B, C, D, E
8890SI	KASKO	277	A++, A+, A, B, C, D, E
8896BI	KASKO	277	A+, A, B
8896GR	KASKO	277	A+, A, B
8896SI	KASKO	277	A+, A, B
8898BI	KASKO	277	A+, A, B
8898GR	KASKO	277	A+, A, B
8898SI	KASKO	277	A+, A, B
9000BI	DOCKS	260	A++, A+, A, B, C, D, E
9000GM	DOCKS	260	A++, A+, A, B, C, D, E
9000GR	DOCKS	260	A++, A+, A, B, C, D, E
9001BI	DOCKS	260	A+, A, B
9001GM	DOCKS	260	A+, A, B
9001GR	DOCKS	260	A+, A, B
9002BI	DOCKS	260	A+, A, B
9002GM	DOCKS	260	A+, A, B
9002GR	DOCKS	260	A+, A, B
9005BI	DOCKS	260	A++, A+, A, B, C, D, E
9005GM	DOCKS	260	A++, A+, A, B, C, D, E
9005GR	DOCKS	260	A++, A+, A, B, C, D, E
9006BI	DOCKS	260	A+, A, B
9006GM	DOCKS	260	A+, A, B
9006GR	DOCKS	260	A+, A, B
9007BI	DOCKS	260	A+, A, B
9007GM	DOCKS	260	A+, A, B
9007GR	DOCKS	260	A+, A, B
9011BI	DOCKS	260	A++, A+, A, B, C, D, E
9011GM	DOCKS	260	A++, A+, A, B, C, D, E
9011GR	DOCKS	260	A++, A+, A, B, C, D, E
9012BI	DOCKS	260	A+, A, B
9012GM	DOCKS	260	A+, A, B
9012GR	DOCKS	260	A+, A, B
9013BI	DOCKS	260	A+, A, B
9013GM	DOCKS	260	A+, A, B
9013GR	DOCKS	260	A+, A, B
9020IN	DOCKS	262	A++, A+, A, B, C, D, E
9021IN	DOCKS	262	A+, A, B

Indice articoli e Classi Energetiche | Code index and Energy class

COD. CODE	SERIE RANGE	PAG. PAGE	CLASSE ENERGETICA ENERGY CLASS	COD. CODE	SERIE RANGE	PAG. PAGE	CLASSE ENERGETICA ENERGY CLASS
9022IN	DOCKS	262	A+, A, B	9077IN	DOCKS	262	A++, A+, A, B, C, D, E
9025IN	DOCKS	262	A++, A+, A, B, C, D, E	9078IN	DOCKS	262	A+, A, B
9026IN	DOCKS	262	A+, A, B	9079IN	DOCKS	262	A+, A, B
9027IN	DOCKS	262	A+, A, B	9080OT	DOCKS	264	A++, A+, A, B, C, D, E
9031IN	DOCKS	262	A++, A+, A, B, C, D, E	9081OT	DOCKS	264	A+, A, B
9032IN	DOCKS	262	A+, A, B	9082OT	DOCKS	264	A+, A, B
9033IN	DOCKS	262	A+, A, B	9084OT	DOCKS	264	A++, A+, A, B, C, D, E
9040OT	DOCKS	264	A++, A+, A, B, C, D, E	9085OT	DOCKS	264	A+, A, B
9041OT	DOCKS	264	A+, A, B	9086OT	DOCKS	264	A+, A, B
9042OT	DOCKS	264	A+, A, B	9087OT	DOCKS	264	A++, A+, A, B, C, D, E
9045OT	DOCKS	264	A++, A+, A, B, C, D, E	9088OT	DOCKS	264	A+, A, B
9046OT	DOCKS	264	A+, A, B	9089OT	DOCKS	264	A+, A, B
9047OT	DOCKS	264	A+, A, B	9101BI	DOCKS	261	A+
9051OT	DOCKS	264	A++, A+, A, B, C, D, E	9101GM	DOCKS	261	A+
9052OT	DOCKS	264	A+, A, B	9101GR	DOCKS	261	A+
9053OT	DOCKS	264	A+, A, B	9102BI	DOCKS	261/319	A+
9060BI	DOCKS	260	A++, A+, A, B, C, D, E	9102GM	DOCKS	261/319	A+
9060GM	DOCKS	260	A++, A+, A, B, C, D, E	9102GR	DOCKS	261/319	A+
9060GR	DOCKS	260	A++, A+, A, B, C, D, E	9104BI	DOCKS	261	A+
9061BI	DOCKS	260	A+, A, B	9104GM	DOCKS	261	A+
9061GM	DOCKS	260	A+, A, B	9104GR	DOCKS	261	A+
9061GR	DOCKS	260	A+, A, B	9105BI	DOCKS	261/319	A+
9062BI	DOCKS	260	A+, A, B	9105GM	DOCKS	261/319	A+
9062GM	DOCKS	260	A+, A, B	9105GR	DOCKS	261/319	A+
9062GR	DOCKS	260	A+, A, B	9106IN	DOCKS	263	A+
9064BI	DOCKS	260	A++, A+, A, B, C, D, E	9107IN	DOCKS	263	A+
9064GM	DOCKS	260	A++, A+, A, B, C, D, E	9108IN	DOCKS	263	A+
9064GR	DOCKS	260	A++, A+, A, B, C, D, E	9109IN	DOCKS	263	A+
9065BI	DOCKS	260	A+, A, B	9110OT	DOCKS	265	A+
9065GM	DOCKS	260	A+, A, B	9111OT	DOCKS	265	A+
9065GR	DOCKS	260	A+, A, B	9114OT	DOCKS	265	A+
9066BI	DOCKS	260	A+, A, B	9115OT	DOCKS	265	A+
9066GM	DOCKS	260	A+, A, B	9117BI	DOCKS	261	A+
9066GR	DOCKS	260	A+, A, B	9117GM	DOCKS	261	A+
9067BI	DOCKS	260	A++, A+, A, B, C, D, E	9117GR	DOCKS	261	A+
9067GM	DOCKS	260	A++, A+, A, B, C, D, E	9119BI	DOCKS	261	A+
9067GR	DOCKS	260	A++, A+, A, B, C, D, E	9119GM	DOCKS	261	A+
9068BI	DOCKS	260	A+, A, B	9119GR	DOCKS	261	A+
9068GM	DOCKS	260	A+, A, B	9121BI	DOCKS	261	A+
9068GR	DOCKS	260	A+, A, B	9121GM	DOCKS	261	A+
9069BI	DOCKS	260	A+, A, B	9121GR	DOCKS	261	A+
9069GM	DOCKS	260	A+, A, B	9122BI	DOCKS	261	A+
9069GR	DOCKS	260	A+, A, B	9122GM	DOCKS	261	A+
9070IN	DOCKS	262	A++, A+, A, B, C, D, E	9122GR	DOCKS	261	A+
9071IN	DOCKS	262	A+, A, B	9124BI	DOCKS	261	A+
9072IN	DOCKS	262	A+, A, B	9124GM	DOCKS	261	A+
9074IN	DOCKS	262	A++, A+, A, B, C, D, E	9124GR	DOCKS	261	A+
9075IN	DOCKS	262	A+, A, B	9125BI	DOCKS	261	A+
9076IN	DOCKS	262	A+, A, B	9125GM	DOCKS	261	A+

COD. CODE	SERIE RANGE	PAG. PAGE	CLASSE ENERGETICA ENERGY CLASS
9125GR	DOCKS	261	A+
9127BI	DOCKS	261	A+
9127GM	DOCKS	261	A+
9127GR	DOCKS	261	A+
9128BI	DOCKS	261	A+
9128GM	DOCKS	261	A+
9128GR	DOCKS	261	A+
9130IN	DOCKS	263	A+
9131IN	DOCKS	263	A+
9133IN	DOCKS	263	A+
9134IN	DOCKS	263	A+
9136IN	DOCKS	263	A+
9137IN	DOCKS	263	A+
9138IN	DOCKS	263	A+
9139IN	DOCKS	263	A+
9140OT	DOCKS	265	A+
9141OT	DOCKS	265	A+
9143OT	DOCKS	265	A+
9144OT	DOCKS	265	A+
9146OT	DOCKS	265	A+
9147OT	DOCKS	265	A+
9148OT	DOCKS	265	A+
9149OT	DOCKS	265	A+
9150BI	KASKO	271	A+
9150GR	KASKO	271	A+
9150SI	KASKO	271	A+
9151BI	KASKO	271	A+
9151GR	KASKO	271	A+
9151SI	KASKO	271	A+
9152BI	KASKO	271/319	A+
9152GR	KASKO	271/319	A+
9152SI	KASKO	271/319	A+
9154BI	KASKO	271	A+
9154GR	KASKO	271	A+
9154SI	KASKO	271	A+
9155BI	KASKO	271	A+
9155GR	KASKO	271	A+
9155SI	KASKO	271	A+
9156BI	KASKO	271/319	A+
9156GR	KASKO	271/319	A+
9156SI	KASKO	271/319	A+
9160BI	KASKO	273	A+
9160GR	KASKO	273	A+
9160SI	KASKO	273	A+
9161BI	KASKO	273	A+
9161GR	KASKO	273	A+
9161SI	KASKO	273	A+
9162BI	KASKO	273	A+
9162GR	KASKO	273	A+

COD. CODE	SERIE RANGE	PAG. PAGE	CLASSE ENERGETICA ENERGY CLASS
9162SI	KASKO	273	A+
9164BI	KASKO	273	A+
9164GR	KASKO	273	A+
9164SI	KASKO	273	A+
9165BI	KASKO	273	A+
9165GR	KASKO	273	A+
9165SI	KASKO	273	A+
9166BI	KASKO	273	A+
9166GR	KASKO	273	A+
9166SI	KASKO	273	A+
9170BI	KASKO	275	A+
9170GR	KASKO	275	A+
9170SI	KASKO	275	A+
9171BI	KASKO	275	A+
9171GR	KASKO	275	A+
9171SI	KASKO	275	A+
9172BI	KASKO	275	A+
9172GR	KASKO	275	A+
9172SI	KASKO	275	A+
9174BI	KASKO	275	A+
9174GR	KASKO	275	A+
9174SI	KASKO	275	A+
9175BI	KASKO	275	A+
9175GR	KASKO	275	A+
9175SI	KASKO	275	A+
9176BI	KASKO	275	A+
9176GR	KASKO	275	A+
9176SI	KASKO	275	A+



Goccia Illuminazione garantisce che i suoi prodotti sono esenti da vizi di fabbricazione, se usati in maniera conforme alla destinazione, per un periodo di cinque anni dalla data della fattura. I dettagli inerenti alla garanzia sono reperibili sul sito www.goccia.it. Goccia Illuminazione riconosce in ogni caso la garanzia di legge.

Goccia Illuminazione guarantees its products are free from manufacturing or material defects, as long as they are used in compliance with their destination use, for a period of 5 years from the invoice date. Any details about can be downloaded by GOCCIA website. Goccia Illuminazione grants anyway the legal warranty.



Consultate sul sito www.goccia.it l'elenco aggiornato degli agenti.

- Questo catalogo annulla e sostituisce tutti i precedenti
- Catalogo ufficiale di riferimento
- Lampadine non fornite con l'apparecchio (salvo diversa indicazione)
- Aggiungere al codice dell'articolo, al posto dell'asterisco, il codice colore specificato nella gamma colori. Esempio: 1308GR. A seguire aggiungere la tonalità del Led (3K-4K). Esempio: 1308GR3K.
- In caso di contestazioni si stabilisce la competenza esclusiva del Foro di Brescia.

www.goccia.it



ITALIANO



ENGLISH

CGT1712 IGB

goccia
ILLUMINAZIONE

Goccia Illuminazione srl

Via E. Fermi, 59/65 | 25020 Poncarale (BS) Italy
T. +39 030 26 40 761 | F. +39 030 26 40 271
info@goccia.it

